

TRAFIC

vehicle user manual





Welcome aboard your vehicle

This user manual contains the information required:

- for you to familiarise yourself with your vehicle, to use it to its best advantage and to fully benefit from all the functions and the technical developments it incorporates.
- to ensure that it always gives the best performance by following the simple, but comprehensive advice concerning regular maintenance.
- to enable you to deal quickly with minor faults not requiring specialist attention.

It is well worth taking a few minutes to read this manual to familiarise yourself with the information and guidelines it contains about the vehicle and its functions and new features. If certain points are still unclear, our Network technicians will be only too pleased to provide you with any additional information.

For guidance, please see the following symbols:

 and  Visible on the vehicle, they show that you should consult the manual to find detailed information and/or limits on operations in respect of equipment on your vehicle.

→ anywhere in the manual indicates a transfer to a page.



anywhere in the manual indicates a hazard, danger or a safety recommendation.

The description of the models given in this manual is based on the technical specifications at the time of writing. **The manual covers all items of equipment (both standard and optional) available for these models, but whether or not these are fitted to the vehicle depends on the version, the options selected and the country where the vehicle is sold.**

This manual may also contain information about items of equipment to be introduced later in the model year.

The diagrams in the user manual are provided as examples only.

Enjoy driving your new vehicle.

Translated from French. Copying or translation, in part or in full, is forbidden unless prior written permission has been obtained from the car manufacturer.

CONTENTS

Welcome aboard your vehicle	4	Driving	179
Exterior	4	Running in.....	179
Passenger compartment	6	Starting, stopping the engine	180
Driver's position	8	Gear control	188
Driving aids	10	Special features of Diesel versions	192
Safety on board	12	Parking brake.....	196
Identifying a vehicle - Labels	14	Environment.....	197
The engine compartment (routine maintenance).....	16	Maintenance and antipollution advice	198
Breakdown recovery	18	Driving advice, eco-driving	199
Getting to know your vehicle	20	Tyre pressure monitoring system	204
Card	20	Driver correction devices and aids	210
Key, remote control.....	34	Additional driving aid functions	214
Doors and opening elements.....	41	Fast idle speed	249
Front seats	54	Speed limiter.....	250
Rear seats	58	Cruise control.....	254
Seat belts.....	63	Adaptive cruise control	258
Additional safety devices	71	Parking aids	269
Child safety	80	Emergency call	278
Child seats	85	Your comfort	281
Child safety: deactivating, activating the front passenger airbag	128	Air vents, heating and air conditioning.....	282
Driving position	130	Multimedia equipment	297
Trip computer	136	Passenger compartment equipment.....	299
Warning lights	153	Passenger compartment storage, fittings	306
Steering	157	Transporting objects	316
Rear view mirrors.....	158	Maintenance	323
Lighting and signals.....	160	Accessing the engine, levels	323
Audible and visual signals	166	Battery	330
Wiper	167	Cleaning.....	332
Fuel tank.....	172	Practical advice	336
Reagent tank	175	Tyres	336

CONTENTS

Breakdown recovery	349
Headlights, lights: replacing bulbs	353
Wiper blades: replacement.....	360
Fuses	363
Fitting a radio	365
Installation and use of accessories.....	366
Operating faults	368
Technical specifications	375
Information about the vehicle	375
Replacement parts and repairs	384
Service sheets	385
Anticorrosion check	391

EXTERIOR

1

56091

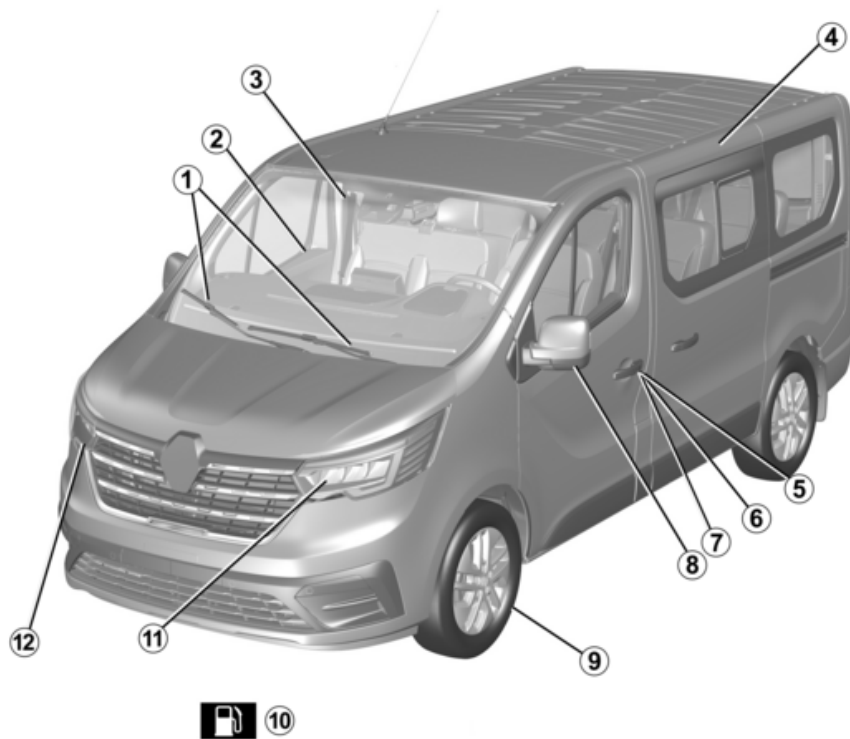

EXTERIOR

1. Screen wiper, washer → 167 → 169
2. Electric windows → 299
3. Demisting → 290 → 286
4. Bodywork maintenance → 332
5. Locking, unlocking the doors → 47
6. Key, Remote control → 34
7. Transmitter-receiver → 20
8. Rear view mirrors → 158
9. Tyres → 336
10. Filling with fuel → 172
11. Lights: operation → 160
12. Lights: replacement → 353

PASSENGER COMPARTMENT

1

56693

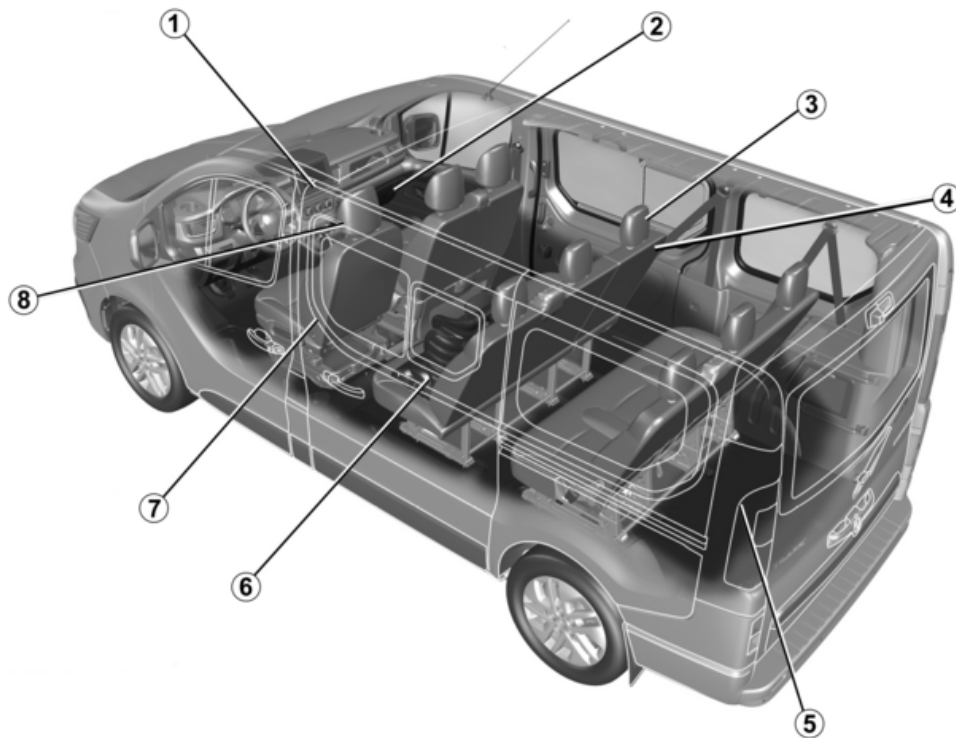

PASSENGER COMPARTMENT

1. Adjusting your driving position → **63**
2. Passenger compartment storage/fittings → **306**
3. Rear headrests → **58**
4. Rear bench seat → **58**
5. Transporting objects → **316**
6. Child safety → **80**
7. Front seats → **54**
8. Front headrests → **54**

DRIVER'S POSITION

1

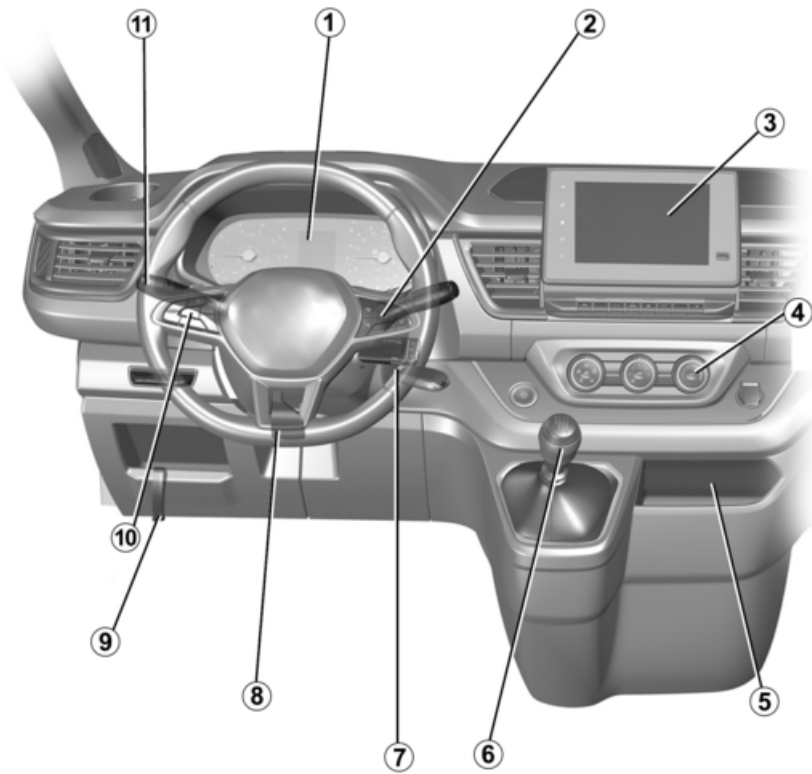

535649

DRIVER'S POSITION

1. Instrument panel → 153
2. Trip computer controls → 136
3. Multimedia screen → 136
4. Heating system/air conditioning → 286 → 290
5. Telephone charging zone → 306
6. Gear lever → 188
7. Ignition switch → 179
8. Steering wheel adjustment → 179
9. Bonnet release → 323
10. Speed limiter → 250/ Cruise control → 254
11. Exterior lighting → 160

DRIVING AIDS

1

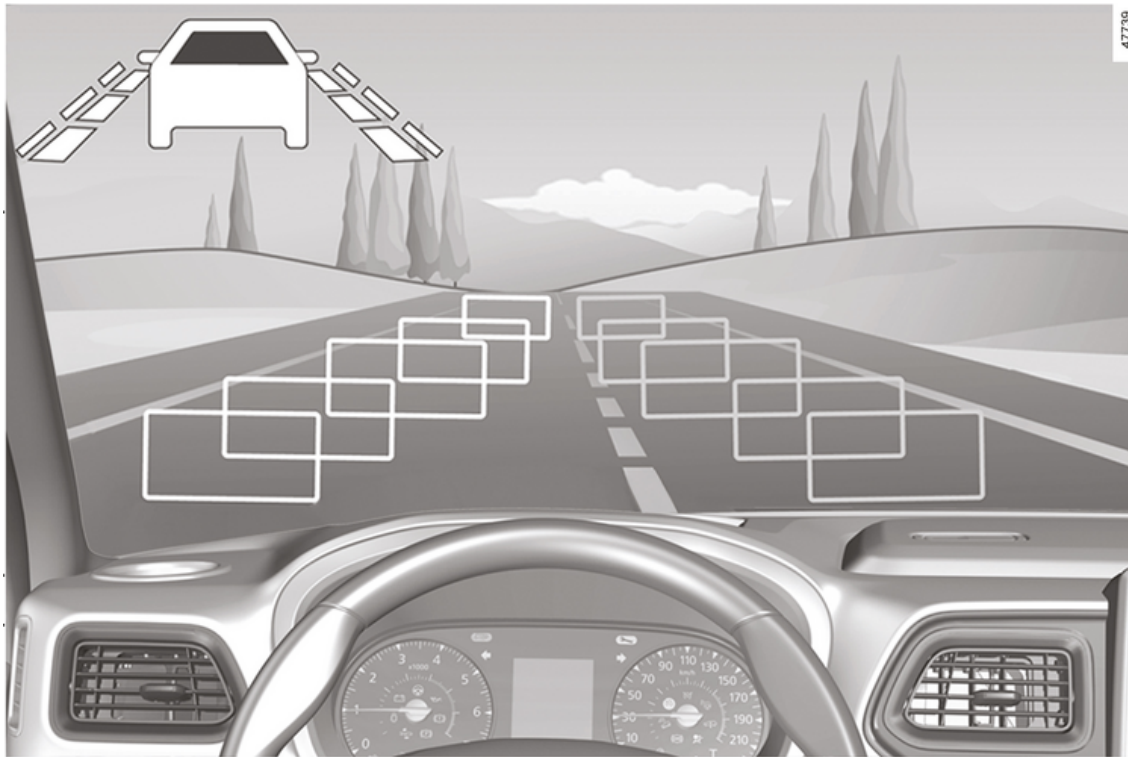

DRIVING AIDS

- Driver correction devices and aids → 210
- Active emergency braking → 233
- Lane departure warning → 216
- Blind spot warning → 223
- Stop and Start → 184
- Speed limiter → 250
- Cruise control → 254
- Park Assist → 269
- Reversing camera → 274
- Road sign detection → 242
- Tyre pressure loss warning → 204
- My Safety → 214

SAFETY ON BOARD

1

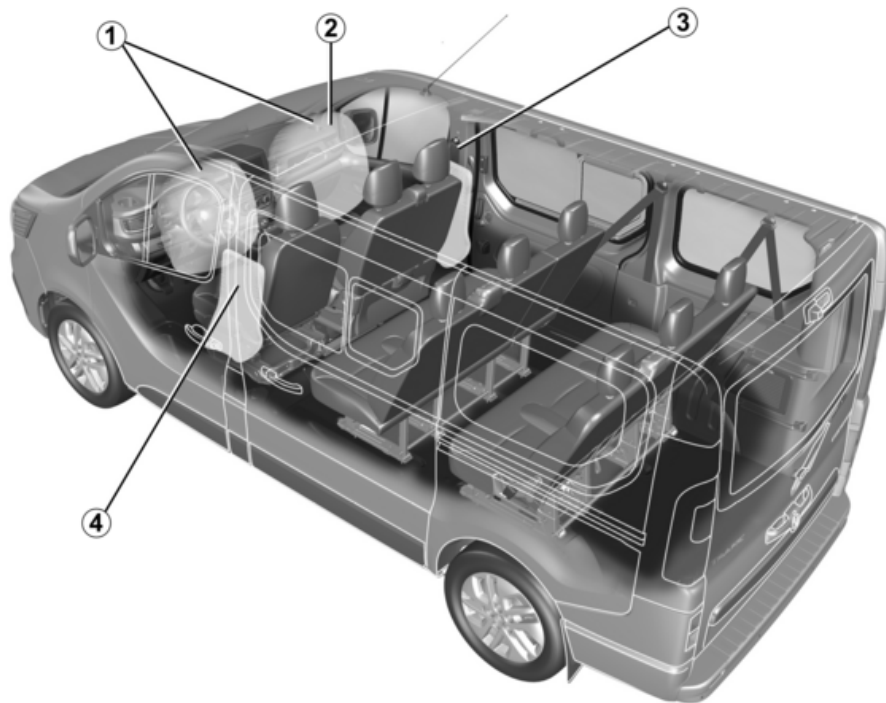

56004

SAFETY ON BOARD

1. Front airbags → 71
2. Deactivating the passenger's front airbag → 71
3. Side airbags → 77
4. Seat belts → 63

IDENTIFYING A VEHICLE - LABELS

1

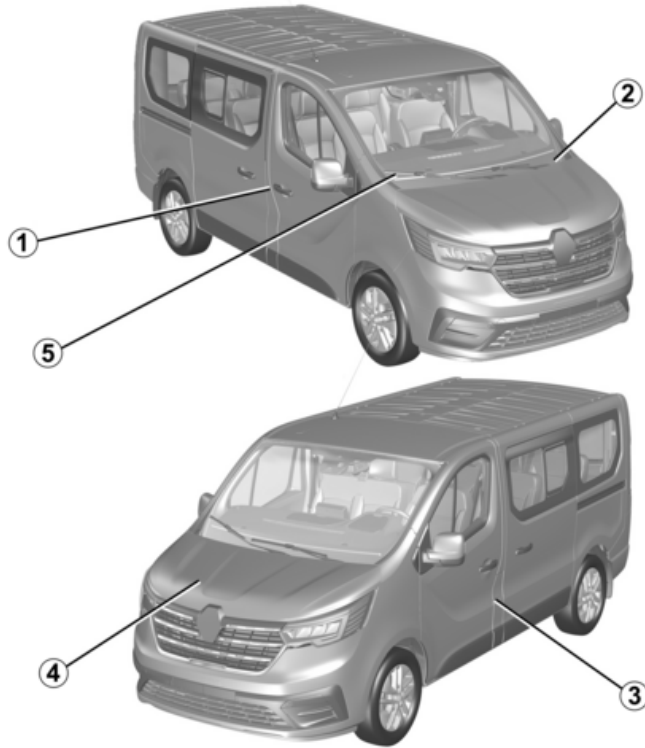

56992

IDENTIFYING A VEHICLE - LABELS

1. Vehicle identification plate → 375
2. Vehicle identification number reminder → 375
3. Tyre pressure labels → 204 → 338
4. Engine identification → 376
5. Technical information for the emergency services → 376

THE ENGINE COMPARTMENT (ROUTINE MAINTENANCE)

1

56695

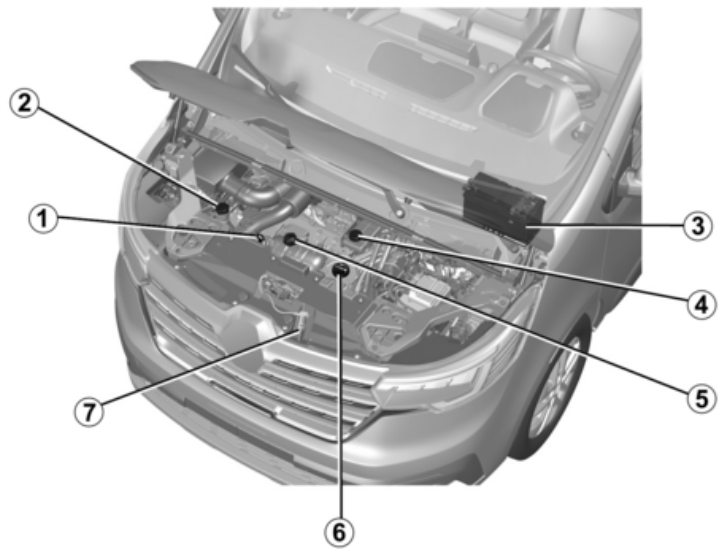

THE ENGINE COMPARTMENT (ROUTINE MAINTENANCE)

1. Engine oil dipstick → 324
2. Screen washer fluid → 327
3. Battery → 330
4. Brake fluid → 327
5. Coolant → 327
6. Engine oil filler cap → 324
7. Opening the bonnet → 323

BREAKDOWN RECOVERY

1

53660

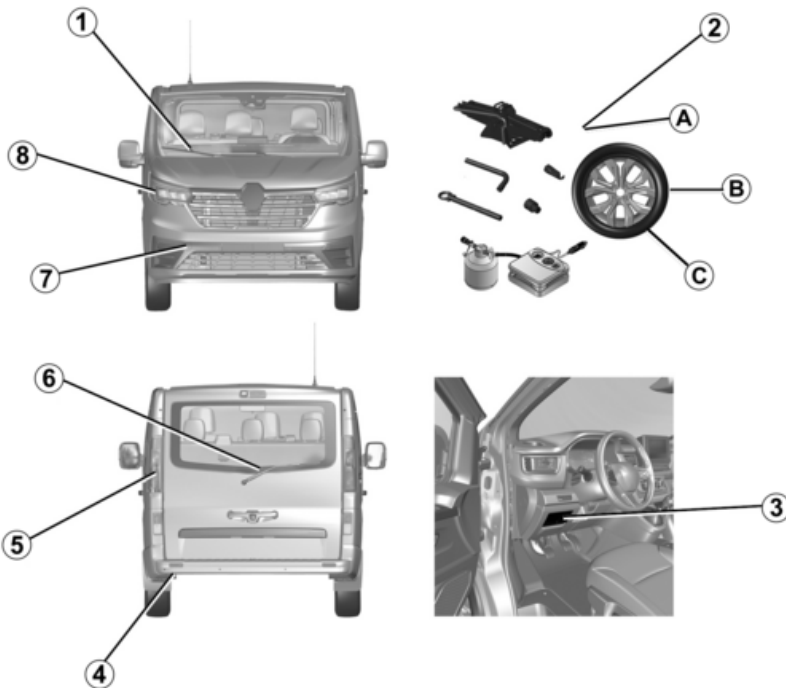

BREAKDOWN RECOVERY

1. Replacing windscreen wiper blade(s) → **360**
2. Puncture:
 - a. Tools → **0**
 - b. Emergency spare wheel → **344**
 - c. Changing a wheel → **0**
3. Fuses → **363**
4. Rear towing point → **349**
5. Replacing rear light bulbs → **353**
6. Replacing the rear screen wiper blade → **360**
7. Front towing point → **349**
8. Replacing headlight bulbs → **353**

CARD

"Hands-free" card

2 General information



Advice

Avoid leaving the card in hot, cold or humid areas.

Keep the card with you.

Do not keep the card in a place where it could be bent or damaged accidentally, such as in your back pocket.

"Hands-free" card (combi version)

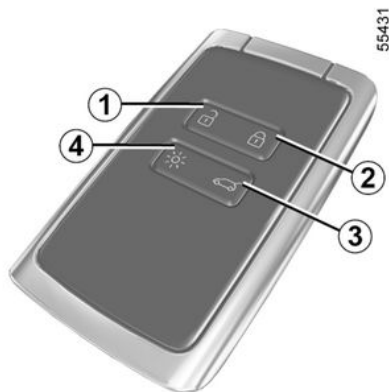

1. Unlocking the doors and luggage compartment.
2. Locks all the opening elements.
3. Unlocking the luggage compartment only.
4. Switching on the lighting remotely.

"Hands-free" card (van version)

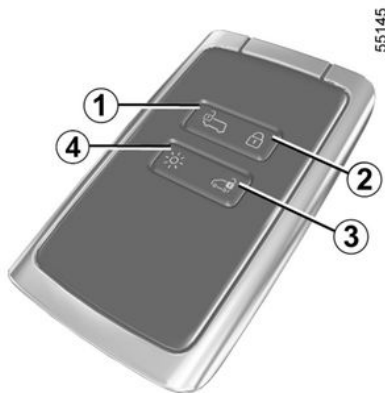

1. Unlocking the front doors and, depending on the vehicle, the sliding side door in Secure mode, or unlocking all the opening elements in Access mode.
2. Locks all the opening elements.
3. Unlocking the rear doors and, depending on the vehicle, the sliding side doors.

4. Switching on the lighting remotely.



Van version card

There are two ways to use the card: access mode and secure mode.

To switch between the card modes of use, access the "ACCESS" menu from the trip computer or multimedia screen, depending on the vehicle. The default mode is Secure mode.

card operating range

This varies according to the surroundings: take care not to accidentally lock or unlock the vehicle by inadvertently pressing the buttons on the card.

Note: if a door or the luggage compartment door is open or not properly shut, the vehicle will not be locked. A beep sounds and the hazard warning lights and side repeaters do not flash.

Interference

Interference by factors in the immediate vicinity (external installations or the use of equipment operating on the same frequency as the card) may disrupt its operation.

CARD

Range

Make sure that the correct battery type is being used, and that the battery is in good condition and inserted correctly. Its service life is approximately two years: it should be replaced when the "Keycard Battery Low" message appears on the instrument panel → **31**.



If the battery is flat, you can still lock/unlock and start your vehicle → **49** → **180**.

"Remote lighting" function



Press button **4** to switch on the dipped beam headlights and the exterior light-

ing for approximately 20 seconds. This can be used, for example, to identify the vehicle from a distance when parked in a car park.

Press and hold button **4** for approximately two seconds to switch on the exterior lighting and emit a sound.

Note: press button **4** again to switch off the lighting.



Replacement: need for an additional card

If you lose your card or require another, you can obtain one from an approved dealer.

If a card is replaced, it will be necessary to take the vehicle **and all its cards** to an approved Dealer to initialise the system.

You may use up to four cards per vehicle.



Driver's responsibility when parking or stopping the vehicle

Never leave an animal, child or adult who is not self-sufficient alone in your vehicle, even for a short time.

They may pose a risk to themselves or to others by starting the engine, activating equipment such as the electric windows or locking the doors.

Also, in hot and/or sunny weather, please remember that the temperature inside the passenger compartment increases very quickly.

RISK OF DEATH OR SERIOUS INJURY.

CARD

Fitting a strap 10

53854



Slide the rear casing **8** downwards while pressing on area **A**.



Never insert screwdriver-type tools into the opening **9**.

57037

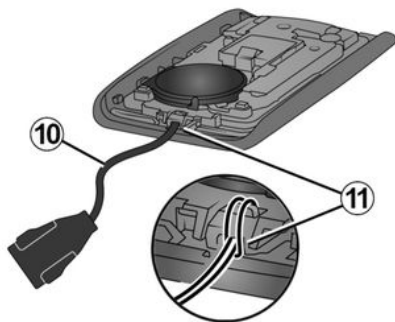

Insert the hand strap into the component **11** and pass the end of the strap through the buckle.

Position the strap at the opening **9** and close the casing.

Note: check that the diameter of the hand strap cord **10** fits the opening **9**.

Use

Card A (combi version)



Driver's responsibility when parking or stopping the vehicle

Never leave an animal, child or adult who is not self-sufficient alone in your vehicle, even for a short time.

They may pose a risk to themselves or to others by starting the engine, activating equipment such as the electric windows or locking the doors.

Also, in hot and/or sunny weather, please remember that the temperature inside the passenger compartment increases very quickly.

RISK OF DEATH OR SERIOUS INJURY.

CARD



There are three ways to unlock/lock the vehicle:

- in "hands-free" mode, when approaching and moving away from the vehicle;
- in "hands-free" mode, depending on the vehicle, using button **2** on the handle **1** of the driver's door, passenger door or luggage compartment door;
- using the card in remote control mode.

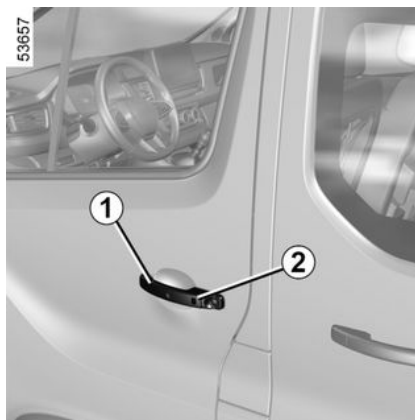

Deactivating/activating the "hands-free mode"

Depending on the vehicle, from the trip computer or the multimedia screen you can deactivate/activate the following:

- unlocking when approaching the vehicle;
- locking when moving away from the vehicle;
- "hands-free" locking and unlocking, completely.

You can also deactivate/activate the sound signal that is emitted upon locking when moving away from the vehicle.



Never leave your vehicle with the card inside.

"Hands-free" unlocking when approaching the vehicle

With the card in the access zone **3**, the vehicle will be unlocked. Unlocking is indicated by **one flash** of the hazard warning lights and the indicator lights.



Depending on the vehicle, the door mirrors fold in/out automatically when the vehicle is locked/unlocked.

CARD

55285

3



"Hands-free" locking when moving away from the vehicle

55286

4



With the card on you and the doors and luggage compartment door closed, move away from the vehicle: it will be locked automatically as soon as you leave the access zone **4**.

Note: the distance at which the vehicle locks depends on the surroundings.

To confirm that the vehicle has been locked, **the hazard warning lights flash twice and then light up** for approximately four seconds accompanied by a beep.

55287

5



The vehicle cannot be remotely locked if the card is within the zone **5**.

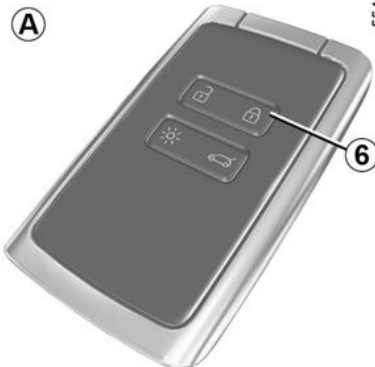

If the card has been within the detection zone **4** for approximately 15 minutes, remote locking is deactivated. To lock the vehicle, press button **6** on the card or, depending on the vehicle, button **2** on one of the handles **1**.

The vehicle cannot be remotely locked if the card is within the zone **4**.

CARD

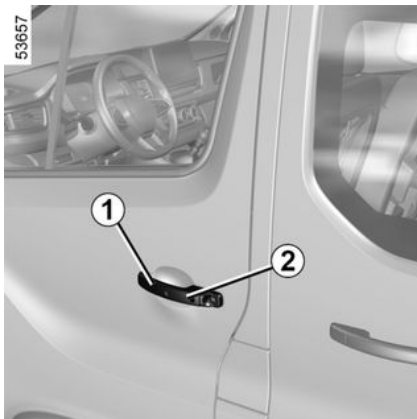

"Hands-free" unlocking/locking using button 2

(depending on the vehicle)

With the card in zone 3 and the vehicle locked, press button 2 on the handle 1 of the driver's door, passenger door or luggage compartment door to unlock the vehicle.

Pressing the tailgate button once unlocks the entire vehicle and opens the tailgate.

The hazard lights and side repeaters flash once to indicate that the doors have unlocked and, on some vehicles, the door mirrors fold out automatically.

55285



With the vehicle unlocked, press button 2 once to lock the vehicle.

The hazard warning lights **flash twice** to indicate that the vehicle is locked and, depending on the vehicle, the door mirrors automatically fold in.



Do not store the card anywhere it may come into contact with other electronic equipment (computer, phone, etc.) as this could hinder its operation.

Special features of the unlocking system

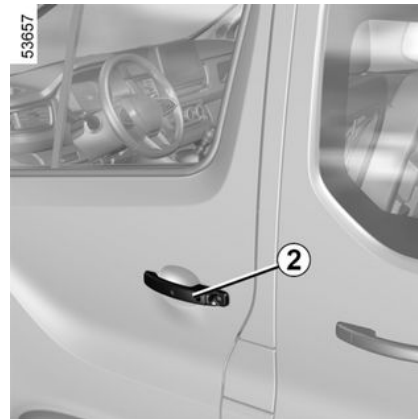

Under certain circumstances, unlocking when approaching the vehicle is deactivated:

- if the vehicle has not been used for eight days;
- if the card remains near to zone 3 of the vehicle for approximately five minutes after the vehicle has been locked;
- after several passes near zone 3 of the vehicle without the doors being unlocked.

Use the card as a remote control (refer to relevant information) or, depending on the vehicle, press button 2 to unlock the vehicle and reactivate "hands-free" mode.

2

CARD

Special features relating to "hands-free" locking

After locking in "hands-free" mode, you have to wait approximately three seconds before being able to unlock the vehicle again.

During these three seconds, the door handles can be tried to make sure that the vehicle is locked properly.

Note: if a door or the luggage compartment door is open or not properly shut, the vehicle will not be locked. A beep sounds and the hazard warning lights and side repeaters do not flash.

Using the card as a remote control **A**

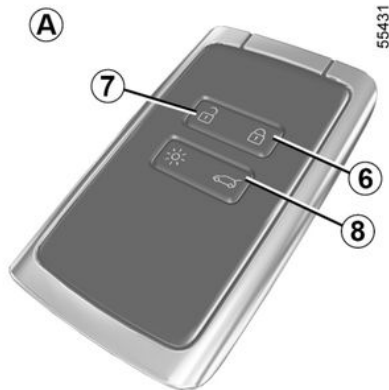

Unlocking with the card

Press the button **7**.

The hazard lights and side repeaters **flash once** to indicate that the doors have unlocked and, on some vehicles, the door mirrors fold out automatically.



The card buttons are deactivated when the engine is running.

Locking using the card

With the doors and luggage compartment door closed, press button **6**: the vehicle will be locked.

The hazard warning lights **flash twice** to indicate that the vehicle is locked and, depending on the vehicle, the door mirrors automatically fold in.

Note:

- the maximum distance at which the vehicle locks depends on the surroundings;
- if a door or the boot is open or not properly shut, locking is not carried out. A beep sounds and the hazard warning lights and side repeaters do not flash.

Unlocking the luggage compartment only

Press button **8** to unlock the luggage compartment only.

55547



With the engine running, if a door is opened and closed and the card is no longer in zone **5**, the "Keycard Not Detected" message indicates that the card is not inside the vehicle. This will, for example, prevent you from driving away after dropping off a passenger who has kept the card on them.

The warning disappears when the card is detected again.

CARD

Card *B* (van version)

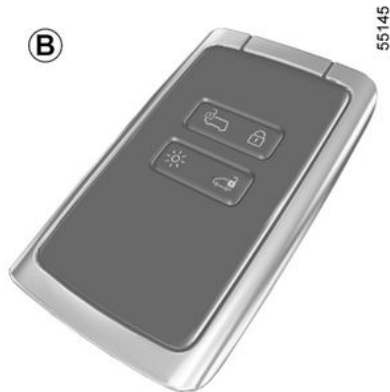

Unlocking the vehicle

There are two ways to unlock the vehicle:

- in "hands-free" mode, using the buttons on the door handles;
- using the card in remote control mode.

Locking the vehicle

There are four ways to lock the vehicle:

- in "hands-free" mode, when moving away from the vehicle;
- in "hands-free" mode, using button **9** on one of the front door handles;

- in "hands-free" mode, using button **10** on one of the sliding side door handles;
- using the card in remote control mode;
- in "hands free" mode, using the button on the handle of the rear door.

Deactivating/activating the "hands-free mode"

Depending on the vehicle, from the trip computer or the multimedia screen you can deactivate/activate the following:

- locking when moving away from the vehicle;
- locking and unlocking by pressing button **9** on the opening element handles.

You can also deactivate/activate the sound signal that is emitted upon locking when moving away from the vehicle. See the relevant information.

"Hands-free" unlocking

 Do not store the card anywhere it may come into contact with other electronic equipment (computer, phone, etc.) as this could hinder its operation.

53717

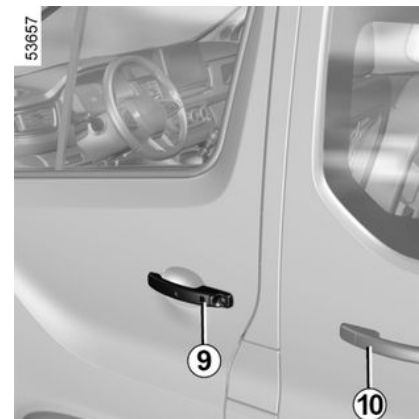

With the card in the access zone **11**:

- press button **9** on the handle of one of the front doors to unlock the front

CARD

doors in secure mode or all of the opening elements in access mode;

- press button **10** on the handle of one of the sliding side doors or on button **12** of the rear hinged door to unlock the rear area in secure mode or all the opening elements in access mode.

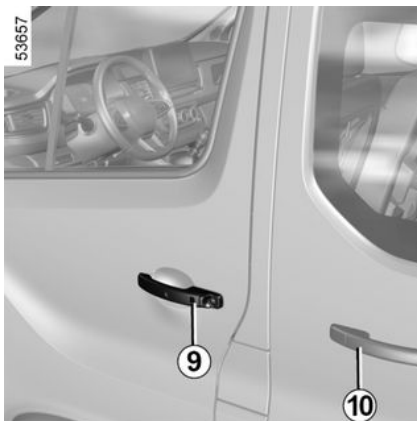

The hazard lights and side repeaters **flash once** to indicate that the doors have unlocked and, on some vehicles, the door mirrors fold out automatically.

"Hands-free" locking

With the vehicle unlocked and all of the opening elements closed, press button **9**, **10** or **12** to lock all of the opening elements.

Secure mode

If one of the front doors is open, press button **9**, **10** or **12** to lock the rear area.



If one of the rear opening elements is open, press button **9**, **10** or **12** to lock the front doors.

Access mode

If an opening element is open or not properly shut, button **9**, **10** or **12** cannot be used to lock.

The hazard warning lights flash twice to indicate that the vehicle is locked and, depending on the vehicle, the door mirrors automatically fold in.

Special features relating to "hands-free" locking

After locking in "hands-free" mode, you have to wait approximately three seconds before being able to unlock the vehicle again.

Note: "hands-free" unlocking/locking will not work if the card is not present within the detection zone for the button being pressed.

55285

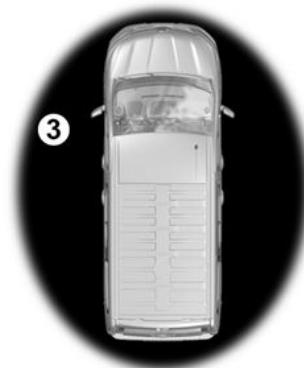

"Hands-free" locking when moving away from the vehicle

With the card on you and the doors and luggage compartment door closed, move away from the vehicle: it will be locked automatically as soon as you leave the access zone **3**.

CARD

Note: the distance at which the vehicle locks depends on the surroundings.

To indicate that the vehicle has been locked, the hazard warning lights flash twice and then light up for approximately four seconds, and a beep sounds in confirmation.



If the card has been within the access zone **3** for longer than approximately 15 minutes, the "locking when moving away" function is deactivated. To lock the vehicle, press the button **8** on the card.

55287



The vehicle cannot be remotely locked if the card is within the zone **14**.

Note: if an opening element (door or luggage compartment door) is open or not properly shut, "hands-free" locking when moving away from the vehicle is not carried out. The hazard warning lights and indicator lights do not flash.

Using the card as a remote control *B*



Driver's responsibility when parking or stopping the vehicle

Never leave an animal, child or adult who is not self-sufficient alone in your vehicle, even for a short time.

They may pose a risk to themselves or to others by starting the engine, activating equipment such as the electric windows or locking the doors.

Also, in hot and/or sunny weather, please remember that the temperature inside the passenger compartment increases very quickly.

RISK OF DEATH OR SERIOUS INJURY

2

CARD

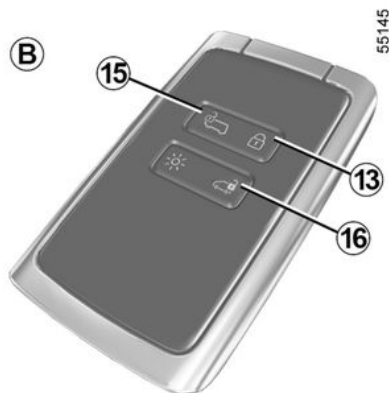

There are two modes of use: **secure mode and access mode**.

To change the card mode of use, access the "ACCESS" menu from the trip computer or the multimedia screen, depending on the vehicle.

The default mode is **Secure mode**.



The card buttons are deactivated when the engine is running.

Unlocking with the card

Press button **16** to unlock the rear, hinged or tailgate doors and, depend-

ing on the vehicle, the sliding side doors.

Secure mode

Press the button **15** to unlock the front doors and, depending on the vehicle, the sliding side door.

Access mode

Press button **15** to unlock all the opening elements.

The hazard warning lights and side repeaters **flash once** to indicate that the doors have unlocked and, on some vehicles, the door mirrors fold out automatically.

Locking using the card

With the doors and luggage compartment door closed, press button **13**: the vehicle will be locked.

The hazard warning lights **flash twice** to indicate that the vehicle is locked and, depending on the vehicle, the door mirrors automatically fold in.

Note:

- the maximum distance at which the vehicle locks depends on the surroundings;
- if a door or the boot is open or not properly shut, locking is not carried out. A beep sounds and the hazard

warning lights and side repeaters do not flash.

53723



With the engine running, if a door is opened and closed and the card is no longer in zone **4**, the "Keycard Not Detected" message indicates that the card is not inside the vehicle. This will, for example, prevent you from driving away after dropping off a passenger who has kept the card on them.

The warning disappears when the card is detected again.

CARD

Deadlocking

53718

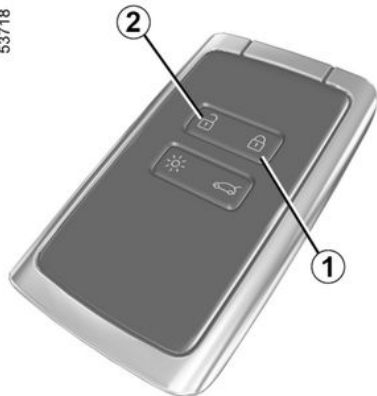

If the vehicle is equipped with a deadlocking function, this allows you to lock the opening elements and to prevent the doors from being unlocked using the interior handles (for example, by breaking the window and then trying to open the door from the inside).



Never use deadlocking if someone is still inside the vehicle.



55145

Special note: deadlocking is not possible if the hazard warning lights or the side lights are lit.



Depending on the vehicle, the door mirrors may fold in automatically when the vehicle is locked.

Activation/deactivation

To activate deadlocking

Press button **2** twice in quick succession.

Locking is confirmed by **two slow flashes and three quick flashes** of

the hazard warning lights and side repeaters.

Depending on the vehicle, the door mirrors may fold in automatically when the vehicle is locked → **158**.

To deactivate deadlocking

Press once on button **1**.

The hazard warning lights flash once to indicate that the doors have been unlocked.

Card: battery



If they need to be replaced, be sure to use the same or equivalent type of battery (consult an Approved Dealer).

CARD

2



Precautions relating to batteries:

- keep batteries (new or used) out of reach of children;
- not to swallow the batteries.

Risk of chemical burns which may lead to death.

- If it may have been ingested or inserted into any part of the body, consult a doctor as soon as possible.



When replacing:

- make sure that the batteries are correctly inserted.

There is a risk of explosion.

- if the flap does not close correctly, do not use and keep out of reach of children.

Replacing the battery

53854



When the "Keycard Battery Low" message appears on the instrument panel, replace the card battery:

- slide the rear casing **1** downwards while pressing on area **A**;
- remove the battery cover **2**;
- remove the battery by pressing on one side and lifting the other;
- replace it according to the direction and template shown inside the cover.

53855



To refit, proceed in the reverse order then press one of the buttons on the card four times while you are near the vehicle: the next time the vehicle is started, the message will disappear.

Check that the cover is clipped shut.

Note: when replacing the battery, do not touch the electronic circuit or contacts on the card.



Check that the cover is clipped shut.

CARD



The batteries are available from approved Dealers, and their service life approximately two years. Check that there is no dye on the battery: risk of an incorrect electrical contact.



Do not throw away your used batteries; give them to an organisation responsible for collecting and recycling batteries.

Operating faults

If the battery is too weak to ensure correct operation, you will still be able to start and lock/unlock the vehicle

→ 180.

26913



KEY, REMOTE CONTROL

General information

2



Driver's responsibility when parking or stopping the vehicle

Never leave an animal, child or adult who is not self-sufficient alone in your vehicle, even for a short time.

They may pose a risk to themselves or to others by starting the engine, activating equipment such as the electric windows or locking the doors.

Also, in hot and/or sunny weather, please remember that the temperature inside the passenger compartment increases very quickly.

RISK OF DEATH OR SERIOUS INJURY.

Key, radio frequency remote control *A* (combi version)



1. Locks all the opening elements.
2. Unlocking the doors and luggage compartment.
3. Locking/unlocking using the switchblade key. To release the insert from its housing, press the button **3** and it will come out. Press the button **3** and guide the insert back into its housing.
4. Driver's door and ignition key.
5. Unlocking the luggage compartment only.

Key, radio frequency remote control *B* (combi version)



1. Locks all the opening elements.
2. Unlocking the doors and luggage compartment.
3. Driver's door and ignition key.
4. Unlocking the luggage compartment only.

KEY, REMOTE CONTROL

Key, radio frequency remote control *C* (van version)

55284



1. Locks all the opening elements.
2. Unlocking the doors and luggage compartment.
3. Locking/unlocking using the switch-blade key. To release the insert from its housing, press the button **3** and it will come out. Press the button **3** and guide the insert back into its housing.
4. Driver's door and ignition key.
5. Unlocking the luggage compartment only.



There are two ways to use the remote control: **access mode** and **secure mode**.

To switch between the remote control modes of use, access the "ACCESS" menu from the trip computer or the multimedia screen, depending on the vehicle. The default mode is **Access mode**.

Key, radio frequency remote control *D* (van version)

55289



1. Locks all the opening elements.

2. Unlocking the doors and luggage compartment.

3. Driver's door and ignition key.

4. Unlocking the luggage compartment only.



There are two ways to use the remote control: **access mode** and **secure mode**.

To switch between the remote control modes of use, access the "ACCESS" menu from the trip computer or the multimedia screen, depending on the vehicle. The default mode is **Access mode**.

Interference

Interference by factors in the immediate vicinity (external installations or the use of equipment operating on the same frequency as the remote control) may affect the operation of the remote control.

KEY, REMOTE CONTROL

i The key must not be used for any function other than those described in the handbook (removing the cap from a bottle, etc.).

i **Replacement and additional keys or remote controls**

You must only contact an approved Dealer:

- if you need to replace a key, it will be necessary to take the vehicle and all of its keys to an approved Dealer in order to initialise the system;
- depending on the vehicle, you have the option of using up to four remote controls.

Remote control unit failure

Always make sure that the correct battery type is being used, and that the battery is in good condition and inserted correctly. These batteries should have a service life of approximately two years. How to change the battery ➔ 0.

i **Recommendations**
Avoid leaving the remote control in hot, cold or humid areas.

Radio frequency remote control operating range

This varies according to the environment: take care not to lock or unlock the doors accidentally by inadvertently pressing the buttons on the remote control.

Note: if a door or the luggage compartment door is open or not properly shut, the vehicle will not be locked. The hazard warning lights and indicator lights do not flash.

Use

Remote control **A** or, depending on the vehicle, remote control **B** can be used to lock or unlock the opening elements. It is powered by a battery which must be replaced ➔ 0.

Locking the doors

Press locking button **1**.

The hazard warning lights and side repeaters **flash twice to indicate that the doors have locked** and, depend-

ing on the vehicle, the door mirrors fold in automatically.

Note: if a door or the luggage compartment door is open or not properly shut, the vehicle will not be locked. The hazard warning lights and indicator lights do not flash, and no beep sounds.

Unlocking the doors

The hazard lights and side repeaters **flash once to indicate that the doors have unlocked** and, depending on the vehicle, the door mirrors fold out automatically.

Combi version

Press button **2** to unlock all of the opening elements.

Van version

Press button **2** to:

- unlock all of the opening elements, in access mode;
- unlocking the front doors and, depending on the vehicle, the sliding side door in Secure mode.

KEY, REMOTE CONTROL

i Depending on the vehicle, the door mirrors fold in/out automatically when the vehicle is locked/unlocked → **158**.

i With the engine running and the ignition on → **179**, the remote control buttons are inactive.



Driver's responsibility when parking or stopping the vehicle

Never leave an animal, child or adult who is not self-sufficient alone in your vehicle, even for a short time.

They may pose a risk to themselves or to others by starting the engine, activating equipment such as the electric windows or locking the doors.

Also, in hot and/or sunny weather, please remember that the temperature inside the passenger compartment increases very quickly.

RISK OF DEATH OR SERIOUS INJURY.

Unlocking the luggage compartment only (combi version)

55284



Using remote control **A** or **B**, press button **3** to unlock the luggage compartment door only.

2

KEY, REMOTE CONTROL

Unlocking the loading area (van version)

2



Using remote control **A** or **B**, press button **3** to unlock the sliding side doors and the rear hinged doors or the tailgate.



Remote controls **A** or **B** van version

There are two ways to use the remote control: **access mode** and **secure mode**.

To switch between the remote control modes of use, access the "ACCESS" menu from the trip computer or the multimedia screen, depending on the vehicle. The default mode is **Access mode**.

Deadlocking



Never use deadlocking if someone is still inside the vehicle.

Special note: deadlocking is not possible if the hazard warning lights or the side lights are lit.

55284



55289



KEY, REMOTE CONTROL

Activation/deactivation

To activate deadlocking

Press button **1** twice in quick succession.

Locking is confirmed by two slow flashes and three quick flashes of the hazard warning lights and side indicator lights.

Depending on the vehicle, the door mirrors may fold in automatically when the vehicle is locked → **158**.

To deactivate deadlocking

Press button **2** once. The hazard warning lights flash once to indicate that the doors have been unlocked.

Radio frequency remote control: battery



When replacing:

- make sure that the batteries are correctly inserted;

Risk of explosion.

- if the flap does not close correctly, do not use and keep out of reach of children.



Precautions relating to batteries:

- keep batteries (new or used) out of reach of children;
- do not swallow batteries;

Risk of chemical burns which may lead to death.

- if ingested or inserted into any part of the body, consult a doctor as soon as possible.

replace the battery **2** observing the type and polarity shown on the back of the cover.



If they need to be replaced, be sure to use the same or equivalent type of battery (consult an Approved Dealer).

53852

Replacing the battery

53853



Open the case at slot **1** using a flat-blade screwdriver or similar tool and

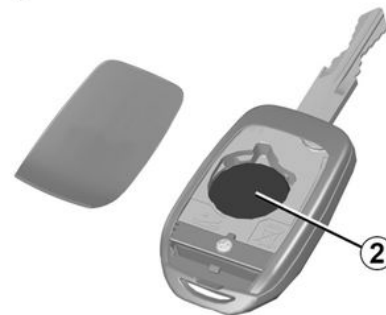

When refitting, ensure that the cover is correctly clipped on and the screw tightened.

Note: it is not advisable to touch the electronic circuit in the key cover when replacing the battery.

KEY, REMOTE CONTROL

2

 When refitting, ensure that the cover is correctly clipped on and the screw tightened.

Operating faults

If the battery is too weak to ensure correct operation, you will still be able to start and lock/unlock the vehicle → 47.

 The batteries are available from approved Dealers, and their service life approximately two years. Check that there is no dye on the battery: risk of an incorrect electrical contact.

26613



 Do not throw away your used batteries as rubbish. Take them to an approved dealer or consult your local authority for information on appropriate recycling facilities.

DOORS AND OPENING ELEMENTS

Front doors



As a safety precaution, the doors should only be opened/closed when the vehicle is stationary.



Driver's responsibility when parking or stopping the vehicle

Never leave an animal, child or adult who is not self-sufficient alone in your vehicle, even for a short time.

They may pose a risk to themselves or to others by starting the engine, activating equipment such as the electric windows or by locking the doors.

Also, in hot and/or sunny weather, please remember that the temperature inside the passenger compartment increases very quickly.

RISK OF DEATH OR SERIOUS INJURY.

Opening from the outside

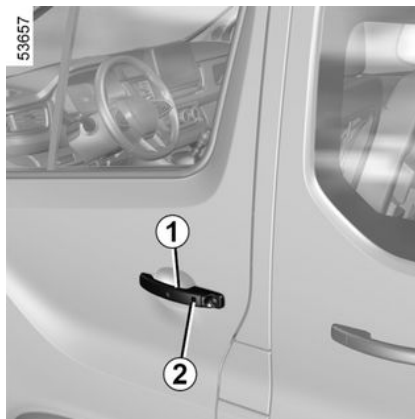

Vehicles with a remote control

Unlock the vehicle using the remote control and pull the handle **1**.

Vehicles with card

(depending on the vehicle)

With the card on you, press button **2** to unlock the vehicle and pull the handle **1**.

Closing from the outside

Push the door. Lock it using the remote control or, on vehicles equipped with a card, press button **2**.

Opening from the inside

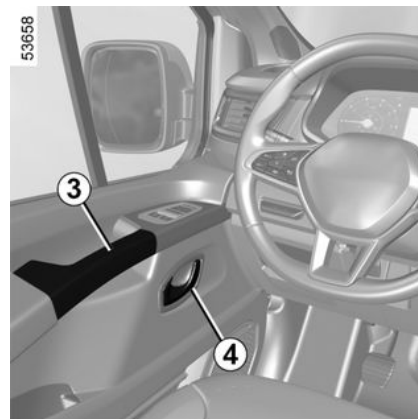

Pull the handle **4** and push the door.

Closing from the inside

Pull the door using only the handle **3**.

Lights-on reminder audible alarm

If you have switched off the ignition and left the lights switched on, a warning buzzer will sound when a door is opened.

Door or luggage compartment lid open buzzer

If a door is open or incorrectly closed, as soon as the vehicle reaches approximately 12 mph (20 km/h), the

DOORS AND OPENING ELEMENTS

"WARNING: Door Open" message appears on the instrument panel accompanied by a warning light.

2

Special feature

Depending on the vehicle, accessories (e.g. radio) stop working either when the engine is switched off or when the driver's door is opened or when the doors are locked.

Sliding side door



Driver's responsibility when parking or stopping the vehicle

Never leave an animal, child or adult who is not self-sufficient alone in your vehicle, even for a short time.

They may pose a risk to themselves or to others by starting the engine, activating equipment such as the electric windows or by locking the doors.

Also, in hot and/or sunny weather, please remember that the temperature inside the passenger compartment increases very quickly.

RISK OF DEATH OR SERIOUS INJURY.



Recommendations concerning the sliding side door.

Care must be taken when opening or closing the sliding door, as is the case for any of the opening elements on the vehicle:

- Check that the door will not come into contact with any person, part of the body, animal or object.
- Never use anything but the handles on the inside and outside of the door to operate it.
- Take care when both opening and closing the door.
- Take particular care when the vehicle is parked on a slope: open or close the door fully until it latches into its locking position.
- Before moving off, always ensure that the sliding door is properly closed.

Vehicles with a remote control

The sliding side door is locked and unlocked by pressing the remote control button.

DOORS AND OPENING ELEMENTS

Vehicles with card



The sliding side door is locked and unlocked:

- by pressing a button on the card;
- depending on the vehicle, by pressing the button on the front doors, the luggage compartment door or the button **2** in hands-free mode (on the van version);
- in hands-free mode by locking/unlocking the front doors or the tailgate.

Opening from the outside

With the vehicle unlocked, pull the handle **1** towards you and slide the door towards the rear.

Closing from the outside

Pull the handle **1** and slide the door towards the front of the vehicle until it closes completely.

Opening from the inside

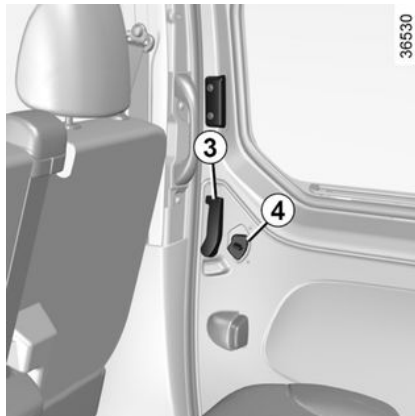

Pull the lever **3** towards the rear and open the sliding door until it locks into position.

Closing from the inside

Pull the lever **3** towards the front and close the door until it latches.

Manual locking from inside

Lower the button **4**. The sliding door is locked.



As a safety precaution, the doors should only be opened/closed when the vehicle is stationary.

2

Child safety

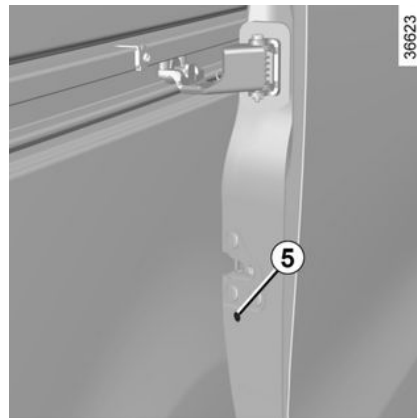

To make it impossible for the rear doors to be opened from the inside: on each door, pivot the bolt **5** and close the door.

Check from the inside that all the doors are locked.

The door can only be opened from the outside of the vehicle.

DOORS AND OPENING ELEMENTS

Rear hinged doors

2



If the vehicle is parked on the hard shoulder with the tailgate open, the rear lights may be obscured. You should make other road users aware of your vehicle by using a warning triangle or other equipment specified by the road traffic regulations of the country you are driving in.



For your safety, check that all the vehicle's doors are properly closed before starting the engine.



Do not leave the hinged rear doors open in case of strong winds.

Risk of injury.

Opening from the outside

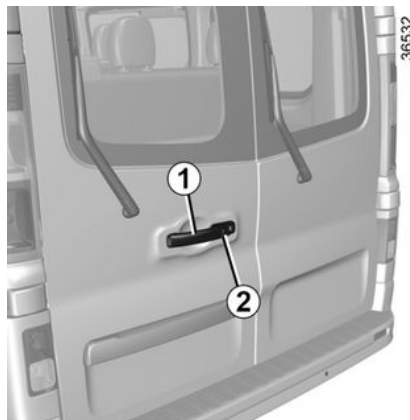

Vehicles with a remote control

Unlock the vehicle using the remote control and pull the handle **1**.

Vehicles with card

(depending on the vehicle)

With the card on you, press button **2** to unlock the vehicle and pull the handle **1**.

Pull the lever **3** to open the door.

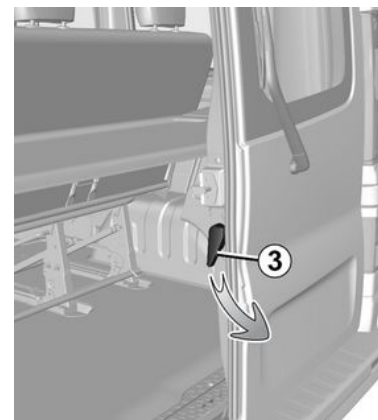

Driving with the right-hand door open

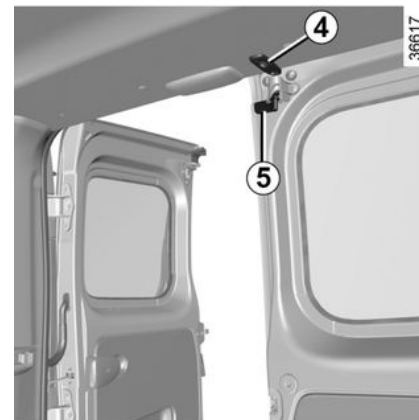

DOORS AND OPENING ELEMENTS

With the right-hand door open, close the left-hand door.

If the vehicle is equipped, lock the left-hand door by turning the lock **5** to set it in the housing **4**.



When driving with the right-hand rear hinged door open, always secure transported loads

→ **316**. The left-hand door, which remains shut, should not be used to hold transported loads in place. Using the right rear hinged door open while driving should only be done in exceptional cases. In any event, please refer to local legislation.

Risk of loads falling on the road surface.

Opening the doors to the maximum position

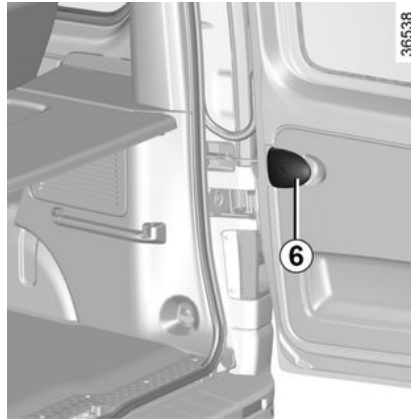

For each door, pull the handle **6** to release the door check strap **7**. Open the door as far as possible.

Closing from the outside

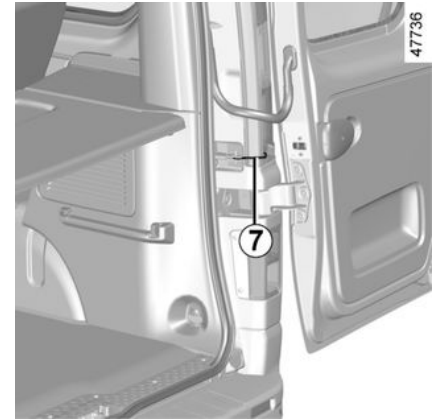

Partially close the right-hand door, then slam it shut.

Then repeat this with the left-hand door before locking.



For your safety, check that all the vehicle's doors are properly closed before starting the engine.

DOORS AND OPENING ELEMENTS

2

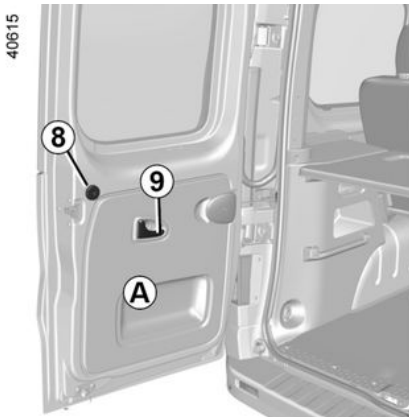

To unlock the door **A** → 47.

Manual locking/unlocking from the inside

Turn the button **8** clockwise to lock the door **A**.

Turn the button **8** anti-clockwise to unlock the door **A**.

Opening from the inside

Pull the handle **9** and push the door **A**.

Pull the lever **3** and open the door **B**.

Closing from the inside

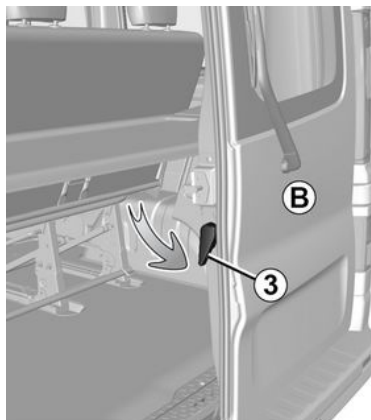

Partially close the door **B** then slam it shut.

Then do the same with door **A**.

Tailgate

Vehicles with a remote control



The tailgate is locked and unlocked by pressing the remote control button.

Vehicles with card

The tailgate is locked and unlocked:

- by pressing a button on the card;
- in hands-free mode by locking/unlocking the front doors;
- depending on the vehicle, in hands-free mode by pressing button **1**.

To open

With the tailgate unlocked, press the button **2** and lift the tailgate.

DOORS AND OPENING ELEMENTS

To close



Lower the tailgate, initially using the interior handle **3**.

When the tailgate has been lowered to shoulder height, release the handle **3** and finish closing the tailgate by pressing down on the tailgate from the outside.

Central locking, unlocking of the opening elements



Driver's responsibility

If you decide to keep the doors locked when you are driving, remember that it may be more difficult for those assisting you to gain access to the passenger compartment in the event of an emergency.



Driver's responsibility when parking or stopping the vehicle

Never leave an animal, child or adult who is not self-sufficient alone in your vehicle, even for a short time.

They may pose a risk to themselves or to others by starting the engine, activating equipment such as the electric windows or locking the doors.

Also, in hot and/or sunny weather, please remember that the temperature inside the passenger compartment increases very quickly.

RISK OF DEATH OR SERIOUS INJURY.

DOORS AND OPENING ELEMENTS

Interior locking/unlocking door control

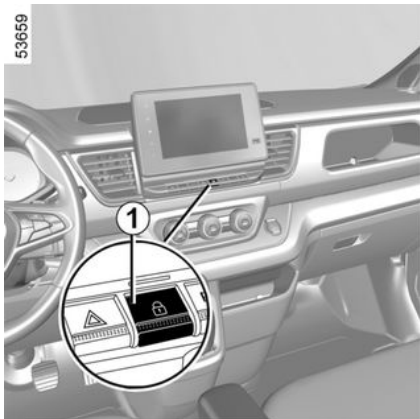

The switch **1** controls all the doors simultaneously.

If a door is open or not properly closed, the doors lock and then quickly unlock.

If transporting an object with the tailgate open, you can still lock the other doors: **with the engine stopped**, press and hold switch **1** for more than five seconds to lock the other doors.

Locking the opening elements without the card or the key

For example, in the event of a discharged battery or the card or key temporarily not working etc.

With the engine off, the rear doors closed and a front door open, press the switch **1** for more than five seconds.

Make sure you have your key or card with you before leaving your vehicle.

When the door is closed, all the doors and tailgate will be locked.

Unlocking from the outside can only be done using the key or the card.



After locking/unlocking the vehicle using the buttons on the card, the "hands-free" locking and unlocking is deactivated.

To reactivate the "hands-free" mode, restart the vehicle.



Never leave your vehicle with the key or card inside.

Doors and tailgate status indicator light

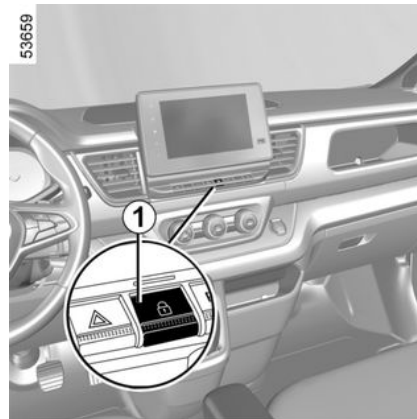

When the ignition is on, the indicator light integrated in switch **1** informs you of the locking status of the opening elements:

- when the warning light is on, the doors and luggage compartment door are locked;
- indicator light off, the doors and tailgate are unlocked.

When the ignition is off, the indicator light remains lit and then goes out when you lock the doors.

DOORS AND OPENING ELEMENTS

Locking the doors with the tailgate open

To lock the vehicle leaving the luggage compartment open (e.g. when transporting something in the luggage compartment which prevents it from being closed), or when the vehicle is located in a zone of high electromagnetic radiation, or if the key is faulty: with the ignition switched off, press and hold the switch **1** for more than five seconds.

Note: if you close the luggage compartment it will lock.

Manual locking, unlocking of the doors



Driver's responsibility

If you decide to keep the doors locked when you are driving, remember that it may be more difficult for those assisting you to gain access to the passenger compartment in the event of an emergency.

If the remote control or, depending on the vehicle, the card does not work

In some cases, the radio frequency remote control or the card may not work:

- card or radio frequency remote control battery flat, vehicle battery discharged, etc.;
- use of appliances operating on the same frequency as the card (mobile phone, etc.);
- the vehicle is located in a high electromagnetic radiation zone.

It is then possible:

- to use the radio frequency remote control or the emergency key integrated into the card (depending on the vehicle) to unlock the driver's door;
- to use the interior door locking/unlocking control → 51.

The card's built-in key



The built-in key **2** can be used to lock or unlock the driver's door when the card is not working.

Accessing the key **2**

Slide the rear casing **1** downwards while pressing on area **A**.

2

DOORS AND OPENING ELEMENTS

53720



2

Using the key integrated in the card

53660

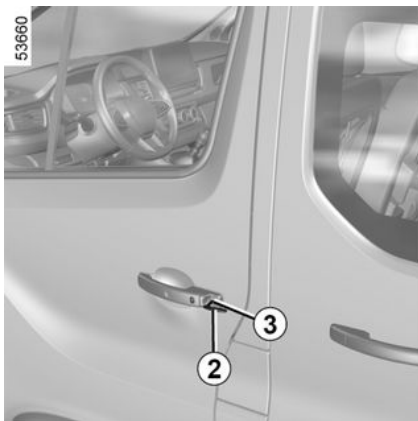

Insert the key **2** into the lock **3** then lock or unlock the driver's door.

Once you are inside the vehicle, put the key back in its casing in the card.

Vehicles with key, remote control

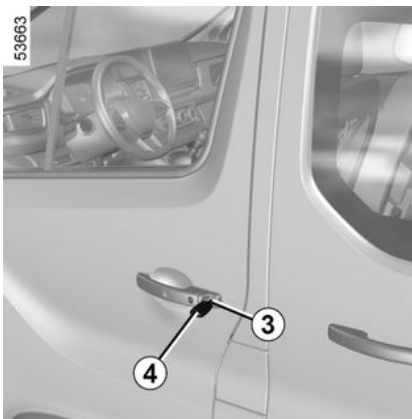

Using the key

Insert the key **4** into the lock of the driver's door, then lock or unlock.

Locking the doors manually

53724

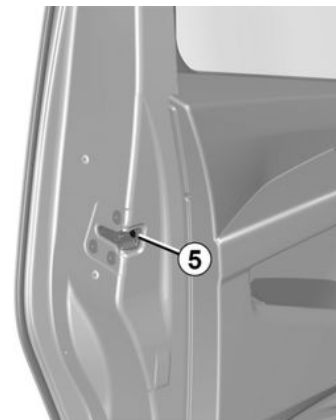

With the door open, turn the screw **5** (using the end of the key) and close the door.

This means that the door is then locked from the outside.

The doors may then only be opened from the inside or by using the key in the driver's door.

DOORS AND OPENING ELEMENTS

Interior locking/unlocking door control

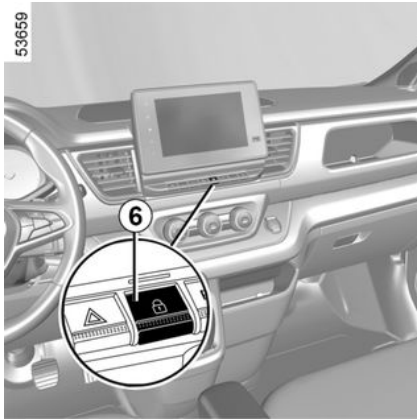

The switch **6** simultaneously controls the doors and the luggage compartment door.

If a door or the tailgate is open or not closed properly, the doors and tailgate lock/unlock quickly.

If transporting an object with the luggage compartment open, you can still lock the other doors: with the engine stopped, press and hold switch **6** for more than five seconds to lock the doors.

Door and tailgate status indicator

With the ignition on, the switch **6** indicator light indicates the locking status of the opening elements:

- when the warning light is on, the doors and luggage compartment door are locked;
- indicator light off, the doors and tailgate are unlocked.

When you lock the doors, the indicator light remains lit and then goes out.



Driver's responsibility

If you decide to keep the doors locked when you are driving, remember that it may be more difficult for those assisting you to gain access to the passenger compartment in the event of an emergency.

DOORS AND OPENING ELEMENTS

Automatic locking when driving

2



Driver's responsibility

If you decide to keep the doors locked when you are driving, remember that it may be more difficult for those assisting you to gain access to the passenger compartment in the event of an emergency.

DOORS AND OPENING ELEMENTS

Operating principle

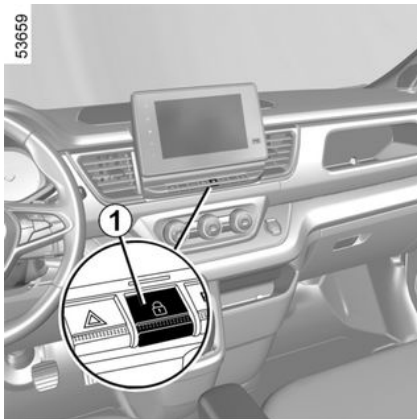

After the vehicle is started, the system automatically locks the doors when you reach approximately 6 mph (10 km/h).

The door can be unlocked:

- by pressing the door unlocking switch **1**;
- at a standstill, by opening a front door from inside the vehicle.

Note: if a door is opened/closed, it will automatically lock again when the vehicle reaches a speed of approximately 6 mph (10 km/h).

Activating/deactivating the function

To activate: with the vehicle stationary and the engine running, press the switch **1**. The "Auto Door Lock ON" message appears on the instrument panel.

To deactivate: with the vehicle stationary and the engine running, press the switch **1**. The "Auto Door Lock OFF" message appears on the instrument panel.

The function can also be activated and deactivated using the trip computer or the multimedia screen (depending on the vehicle).

Operating faults

If you experience an operating fault (no central locking, the switch light **1** does not light up when trying to lock the doors and luggage compartment, etc.), make sure that central locking has not been deactivated by mistake and check that all of the opening elements are properly closed. If they are properly closed, contact an approved dealer.

FRONT SEATS

Front headrests

2



The headrest is an important safety component: ensure that it is in place and in the correct position. The top of your head should be in line with the top of the headrest. The distance between your head and section **A** should be as short as possible.

To raise the headrest

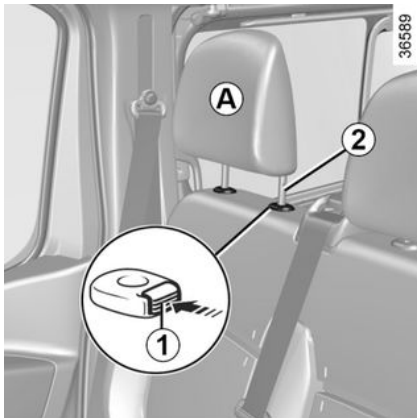

Pull the headrest upwards to the desired height. Check that it is correctly locked.

To lower the headrest

Press the button **1** and guide the headrest down to the desired height. Check that it is correctly locked.

To remove the headrest

Raise the headrest to its highest position (tilt the seatback if necessary). Press button **1** and lift the headrest to release it.

To refit the headrest

Insert the headrest rods into the holes (tilt the seatback if necessary). Lower the headrest until it locks and press button **1** to adjust to the desired height. Check that each rod **2** is locked on the seatback.

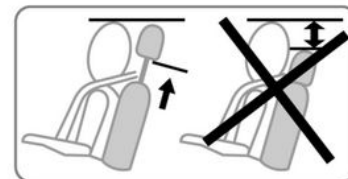

Front seats

Seat adjustments



After making adjustments, make sure that the seatbacks are correctly locked in place.

FRONT SEATS



For safety reasons, carry out any adjustments while the vehicle is stationary.

We would advise you not to recline the seatbacks too far to ensure that the effectiveness of the seat belts is not reduced.

Nothing should be placed on the floor (area in front of the driver) as these objects may slide under the pedals during sudden braking manoeuvres, thus obstructing their use.



To move a seat forwards or backwards

Raise the handle **1** to unlock it. Release the handle once the seat is in the correct position and ensure that the seat is locked.

To adjust the height of the seat base

Lower or pull the lever **3** as many times as is necessary to lower or raise the seat base.

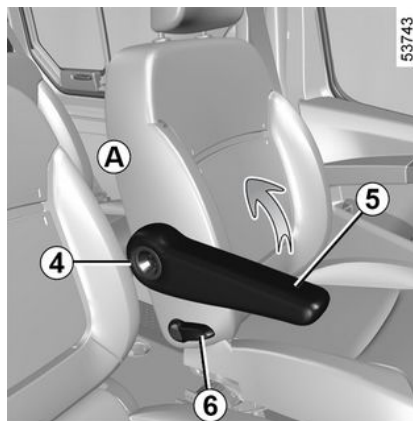

Lumbar adjustment

To make it easier to adjust the lumbar position, raise the armrest **5**. Turn the

control knob **4** to increase or decrease the lumbar support.

Front armrests **5**

Depending on the vehicle, the front armrests **5** can be adjusted.

To adjust the armrest upwards, raise the armrest to the desired position.

To adjust the armrest downwards, raise the armrest to the storage position along the backrest and then lower it.

To store the armrest, raise the armrest to the storage position **A**. Check that it is correctly locked.

To tilt the seatback

Handle the lever **6**.

Heated seats

With the ignition on, press the switch **2**. The integrated warning light comes on.

The system, which has a thermostat, regulates the heating and deactivates it if necessary.

Central passenger seat table formation

(depending on the vehicle)

FRONT SEATS

2



After making adjustments, make sure that the seatbacks are correctly locked in place.



For your safety, attach any transported objects when the seat is in the table position.



When the front seatback is in the table position, you must deactivate the front passenger Airbag

→ 128.

Risk of serious injury caused by items resting on the seatback table which may be dislodged when the Airbag is deployed. The label (on the dashboard) and the markings (on the windscreen) remind you of these instructions.



When folding down the front seatback to the table position, it is recommended not to use the side seat and to leave it unoccupied.



Make sure that nothing prevents the seat from moving.

- Hold the seatback by the top to guide it downwards and simultaneously activate the control 7 while folding the seatback forwards;
- press on the back of the seatback to lock it in place. Make sure you lock the seatback properly.

To reposition the central passenger seat

Make sure that nothing prevents the seat from moving.

- Activate the control 7 to unlock the seatback;
- lift the seatback;
- Make sure the seat is correctly locked in position.

Front centre seat with folding seatback for emergency exit

(depending on the vehicle)

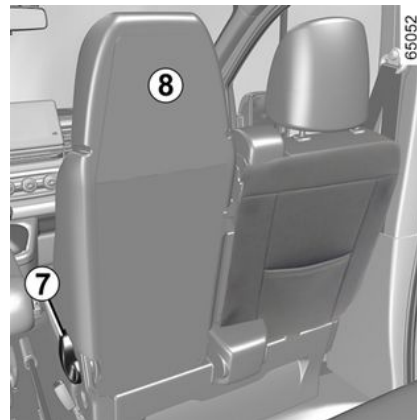

The front centre seat is equipped with a folding seatback 8 to enable an emergency exit.

FRONT SEATS

Make sure that nothing prevents the seatback from moving.

To fold down the seatback **8**:

- hold the seatback by the top to guide it downwards;
- unlock the seatback using the handle **7** then push the seatback forwards.

Note: when repositioning the seatback to the driving position, ensure that it is correctly locked.



For your safety, do not drive with the front seat folded down **8**.

Risk of very serious injury if the airbag is triggered.

Instructions label

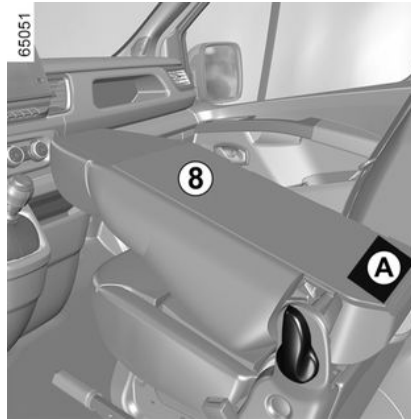

The markings on label **A** located on the back of the front folding emergency exit seat **8** provide a reminder that:

- it is prohibited to drive while the front folding emergency exit seat is folded down;
- it is prohibited to place heavy loads on the front folding emergency exit seat.

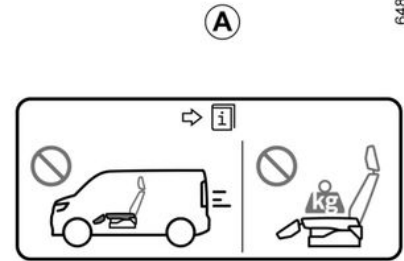

REAR SEATS

Rear headrests



The headrest is a safety component; check that it is fitted and in the correct position.

To remove the headrest

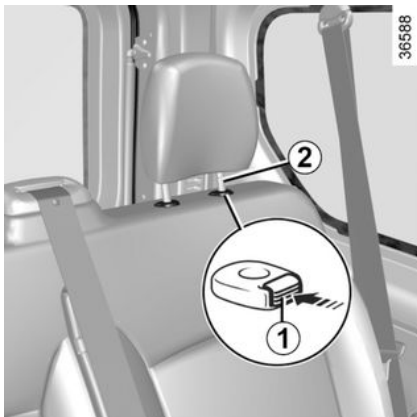

Press button **1** and lift the headrest to release it (tilt the seatback if necessary).

To refit the headrest



Insert the headrest rods into the holes (tilt the seatback if necessary). Lower the headrest as far as it will go, then lift until it locks into place. Check that each rod **2** is locked on the seatback.

Rear bench seats

Functions



For safety reasons, carry out any adjustments while the vehicle is stationary.

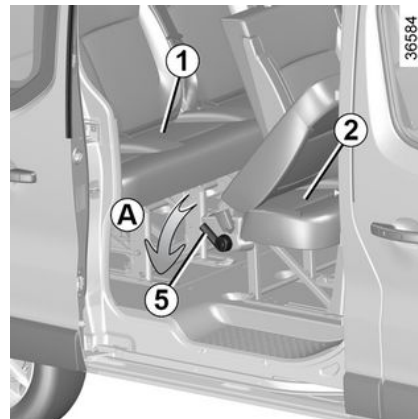

Depending on the vehicle, there may be two rear bench seats: bench seat **2** (second row of seats) and bench seat **1** (third row of seats).

Bench seat 2



Ensure that the bench seats are locked in place correctly when refitting them.

Check that the side seat belts are locked in their unit correctly.

REAR SEATS

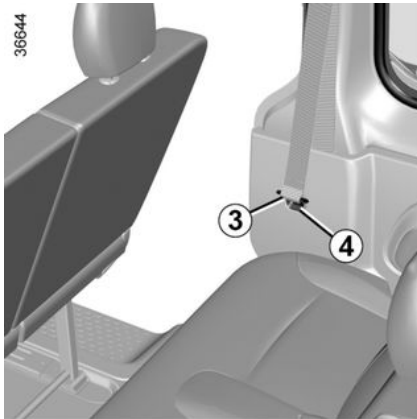

Insert the buckles **3** into the catches **4** before moving the seatback(s).

To facilitate access to the last row (bench seat **1**), move control **5** downwards (movement **A**) to tilt the bench seatback **2**.

Remember to lock the seat belt in place once more when a passenger is occupying the seat.

Emergency exit

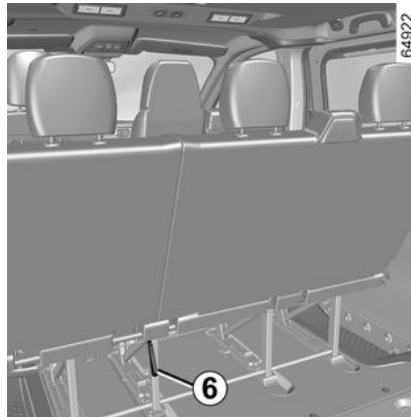
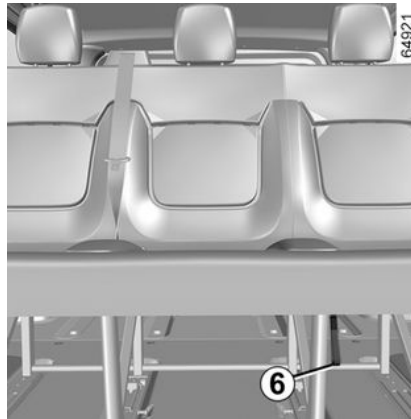

In the event of an emergency exit, use one of the two red straps **6** located un-

derneath the second row bench seat **3**.

They can be accessed from the front (second row) and rear (third row).

To unlock the bench seatback, pull one of the red straps **4** then tilt the seatback forwards.

Bench seat 1

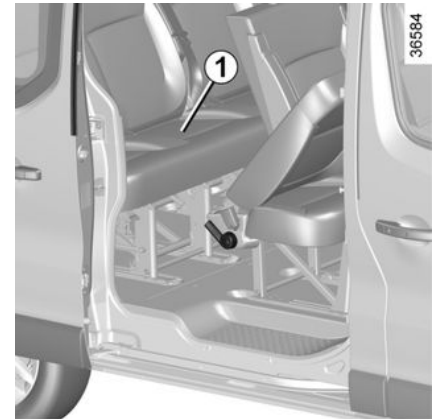

This can be folded away and folded down.

2

REAR SEATS

2

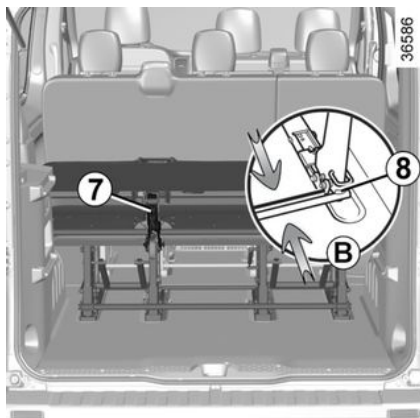

To fold it down

- Pull the seatback unlocking strap **7**;
- fold down the seatback onto the seat base.



When moving the rear bench seat, check that the bench seat anchorage points are clean (they should be free from grit, cloths or any other item which may prevent the bench seat from locking securely).

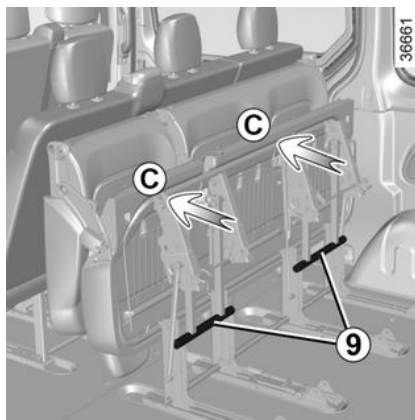

To fold down

(depending on the vehicle)

- Hold the bars **8** and bring them together simultaneously (movement **B**);
- tilt the seat unit forwards until it locks;
- press the top of the seat base (at **C**) and lock the seat in position by pushing the locking levers **9**;
- ensure it is correctly locked in place.

Removal/refitting of bench seats **1** and **2**

(depending on the vehicle)



Ensure that the bench seats are locked in place correctly when refitting them.

Check that the side seat belts are locked in their unit correctly.



The rear bench seats must be placed on their original anchorage points.

Driving with the "bench seat in a rear-facing position" is prohibited.



For safety reasons, carry out any adjustments while the vehicle is stationary.



It is prohibited to swap bench seats **1** and **2**.

REAR SEATS

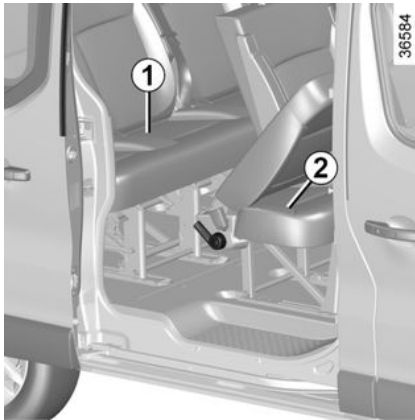

These are removed and refitted in the same way.

Removal

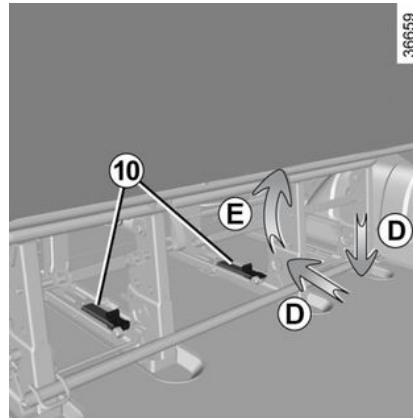

First, release the side seat belts by unlocking them from their unit.

- Underneath the bench seat, press the lock **9** then pull it towards the front (movement **D**);
- lift it (movement **E**);

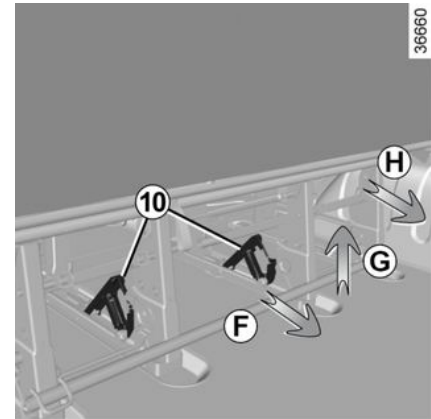

- move the bench seat towards the rear of the vehicle to release the anchorage points (movement **F**);
- lift the bench seat (movement **G**);
- move the bench seat towards the rear again (movement **H**) to release the front anchorage points;
- remove the bench seat from the front of the vehicle.

 Remove bench seat **2** before removing bench seat **1**.

2

REAR SEATS

Refitting

2

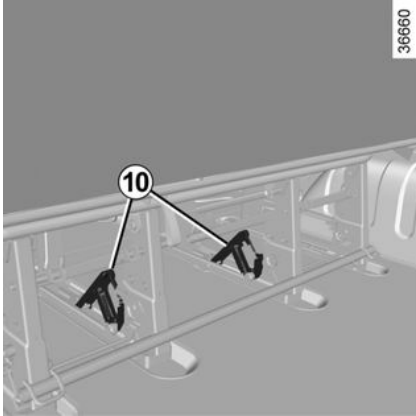

- Position the bench seat over the front anchorage points;
- push the bench seat until it sits over the rear anchorage points;
- lower the locks **9** and press them until the lock;
- make sure that the visual markers on the locks **9** are properly aligned.

SEAT BELTS

Front seat belts

Always wear your seat belt when travelling in your vehicle. You must also comply with the legislation of the particular country you are in.

Before starting, first adjust your driving position, then ask all occupants to adjust their seat belts to ensure optimum protection.



Make sure that the rear bench seat → 58 is locked in position correctly so that the rear seat belts will operate correctly.



Incorrectly adjusted or twisted seat belts may cause injuries in the event of an accident.

Use one seat belt per person, whether child or adult. Even pregnant women should wear a seat belt. In this case, ensure that the lap belt is not exerting too much pressure on the abdomen, but do not allow any slack.

Adjusting your driving position

- **Sit well back in your seat** (having removed your coat or jacket, etc.). This is essential to ensure that your back is positioned correctly;
- **adjust the distance between the seat and the pedals.** Your seat should be as far back as possible while still allowing you to fully depress the pedals. The seatback should be adjusted so that your arms are slightly bent when you hold the steering wheel;
- **adjust the position of your headrest.** For maximum safety, your head must be as close as possible to the headrest;
- **adjust the height of the seat.** This adjustment allows you to select the

seat position which offers you the best possible view;
– **adjust the position of the steering wheel.**

Adjusting the seat belts



To ensure the correct adjustment and positioning of the seat belts on all seats:

- adjust the seats (seat position and seatback angle, if available);
- sit with your back firmly against the seatback;
- move the shoulder strap **1** as close as possible to the base of the neck without it actually resting against it (if necessary, adjust the height of the seat belt if possible) and make sure that the

SEAT BELTS

shoulder strap **1** is in contact with the shoulder;

– position the lap belt **2** so that it lies flat on the thighs and against the pelvis.

The seat belt must be worn as close to the body as possible. e.g. avoid wearing heavy clothing, keeping bulky objects under the belts, etc.

Locking



Unwind the belt **slowly and smoothly** and ensure that the buckle **3** locks into the catch **5** (check that it is locked by pulling on the buckle **3**).

If the belt jams, allow it to return slightly before attempting to unwind it again.

If your seat belt is completely jammed, pull slowly, but firmly, so that just over 3 cm unwinds. Allow it to wind up, then unwind it again.

If there is still a problem, contact an approved dealer.

Unlocking

Press the button **4** and the seat belt will be rewound by the inertia reel. Guide the belt.

Adjusting the height of the front seat belts

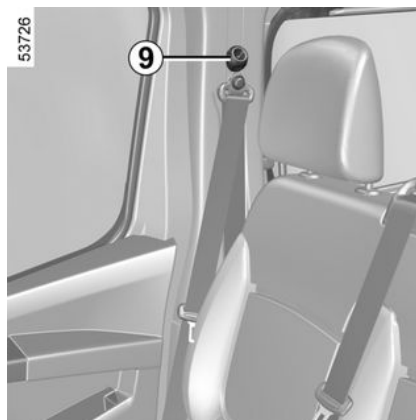

Move button **9** to select the position you require so that the shoulder strap **1** is worn as described above.

Make sure that the seat belt is locked in position correctly after you have adjusted it.

Driver's seat belt reminder and, depending on the vehicle, front passenger seat belt reminder



 This warning light appears on the central display **A** when the vehicle ignition is switched on and if the driver's and/or front passenger's seat belt(s) (if the passenger seat is occupied) is not fastened.

Depending on the vehicle, if the seat is occupied and one of these seat belts is not fastened or becomes unfastened while the vehicle is moving at a speed

SEAT BELTS

over approximately 12 mph (20 km/h),

the  warning light flashes and a beep sounds for approximately 120 seconds.

Note: placing an object on the passenger seat base may activate the warning light in some cases.

Seat belt reminder: instrument panel **B**

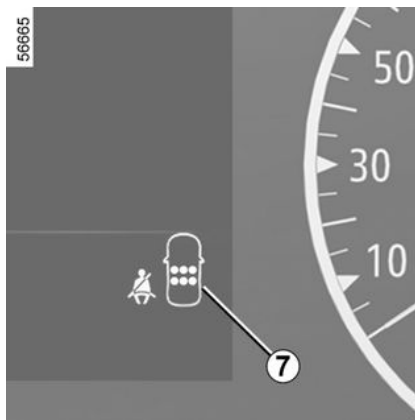
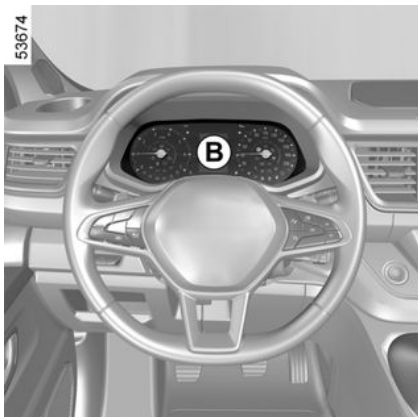

Front seat belt reminder (depending on the vehicle)

With the doors closed, the graphic **7** is displayed on the instrument panel for approximately 60 seconds when the vehicle ignition is switched on. This informs the driver of the fastening status of each of the rear seat belts every time:

- the doors are opened during driving (vehicle speed above zero);
- a front seat belt is fastened/unfastened.

Understanding the graphic **7**:



seat belt fastened;



seat occupied and seat belt unfastened;



seat not occupied.

With the doors closed, the  warning light is displayed on the central display **A** when the ignition is switched on and if the driver's and/or front passenger(s) seat belt is not fastened (if the seat is occupied).

When the vehicle speed is less than approximately 12 mph (20 km/h), the



warning light appears on the central display **A** if a front seat is occupied and the seat belt is not fastened. It is accompanied by the graphic **6** which appears for approximately 60 seconds each time one of the front seat belts is fastened or unfastened.

When the vehicle speed reaches or exceeds 12 mph (20 km/h), if one of the front seat belts is or becomes unfastened during the journey:

- the  warning light flashes on the central display **A**;
- and

SEAT BELTS

– a beep sound for approximately 120 seconds;

and

– the graphic 7 is displayed for approximately 180 seconds and the



symbol appears for the seat concerned.

Always make sure that the front passengers are properly fastened in and that the number of seat belts indicated as fastened corresponds to the number of front seats occupied.

Note: an object placed on the front passenger seat may trigger warnings in some cases.

Rear seat belt reminder (depending on the vehicle)

With the doors closed, the graphic 7 is displayed on the instrument panel for approximately 60 seconds when the vehicle ignition is switched on. This informs the driver of the fastening status of each of the rear seat belts every time:

- the doors are opened during driving (vehicle speed above zero);
- a rear seat belt is fasted or unfastened.

Understanding the graphic 7:

66 - Getting to know your vehicle



seat belt fastened;



seat occupied and seat belt unfastened.

When the vehicle speed is below approximately 12 mph (20 km/h), the graphic 7 appears during approximately 60 seconds every time one of the rear seat belts is fastened or unfastened.

When the vehicle speed reaches or exceeds 12 mph (20 km/h), if one of the rear seat belts is unfastened during the journey:

– the  warning light flashes on the central display A;

and

– a beep sound for approximately 30 seconds;

and

– the graphic 7 is displayed for at least 60 seconds and the



symbol for the seat concerned is displayed.

Always make sure that the rear passengers are properly fastened in and that the number of seat belts indicated corresponds to the number of rear seats occupied.

Seat belt reminder: instrument panel C

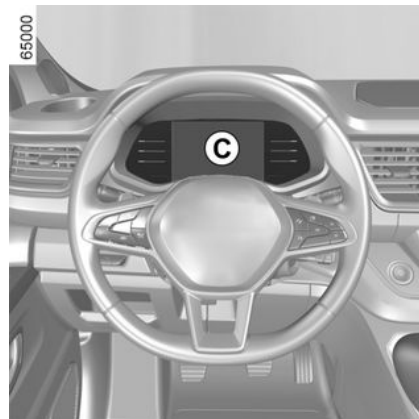

SEAT BELTS



Front seat belt reminder

With the doors closed, the graphic **8** is displayed on the instrument panel for approximately 60 seconds when the vehicle ignition is switched on. This informs the driver of the fastening status of each of the rear seat belts every time:

- the doors are opened during driving (vehicle speed above zero);
- a seat belt is fastened/unfastened.

Understanding the graphic **8**:

- **symbol in green**: seat belt fastened;
- **symbol in red**: seat occupied and seat belt not fastened;
- **symbol in grey**: seat not occupied.

With the doors closed, the  warning light appears on the central display when the vehicle ignition is switched on if the driver's and/or passenger's seat belt(s) (if this seat is occupied) are not fastened.

When the vehicle speed is less than approximately 12 mph (20 km/h), the

 warning light appears on the central display **A** if a seat is occupied and the seat belt is not fastened. It is accompanied by the graphic **8** which appears for approximately 60 seconds each time one of the seat belts is fastened or unfastened.

When the vehicle speed reaches or exceeds 12 mph (20 km/h), if one of the rear seat belts is unfastened during the journey:

- the  warning light flashes on the central display **A**;
- and
- a beep sound for approximately 120 seconds;
- and
- the graphic **8** is displayed for at least approximately 180 seconds and the symbol for the seat concerned appears in red.

Always make sure that the rear passengers are properly fastened in and that the number of seat belts indicated as fastened corresponds to the number of seats occupied.

Note: in some cases, the warnings may be triggered if an object is placed on one of the seats.

Rear seat belt reminder (depending on the vehicle)

With the doors closed, the graphic **8** is displayed on the instrument panel for approximately 60 seconds when the vehicle ignition is switched on. This informs the driver of the fastening status of each of the rear seat belts every time:

- the doors are opened during driving (vehicle speed above zero);
- A rear seat belt is fastened/unfastened.

Understanding the graphic **8**:

- indicator green: seatbelt fastened;
- indicator red: seatbelt unfastened.

When the vehicle speed is below approximately 12 mph (20 km/h), the graphic **8** appears during approximately 60 seconds every time one of the rear seat belts is fastened or unfastened.

When the vehicle speed reaches or exceeds 12 mph (20 km/h), if one of

SEAT BELTS

the rear seat belts is unfastened during the journey:

2

- the  warning light flashes on the central display **A**;
- and
- a beep sound for approximately 30 seconds;
- and
- the graphic **B** is displayed for at least approximately 60 seconds and the symbol for the seat concerned appears in red.

Always make sure that the rear passengers are properly fastened in and that the number of seat belts indicated corresponds to the number of rear seats occupied.

Rear side seat belts



Check that the rear seat belts are positioned and operating correctly each time the rear bench seat is moved.

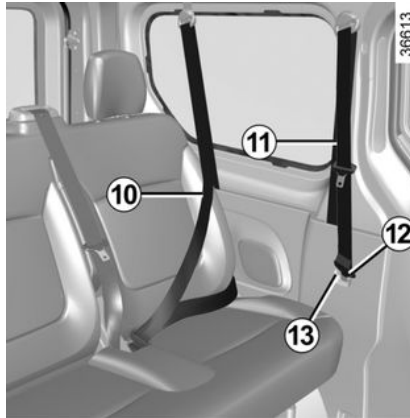

- For the first row of rear seats, it is **essential** to use seat belts **11**;
- for the last row of rear seats, it is **essential** to use seat belts **10**.

For the first rear row, when belt **11** is not in use, insert the fixed buckle **12** into the catch **13**.

For the last rear row, when belt **10** is not in use, insert the fixed buckle **14** into the catch **15**.

Conditions of use

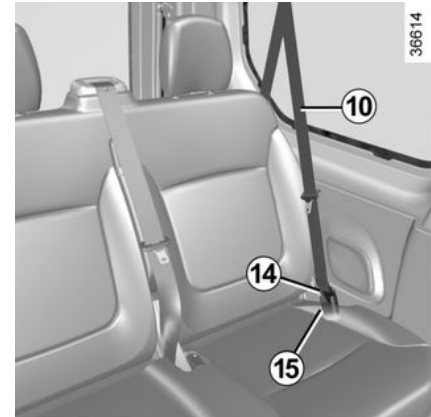

Before using the rear side seat belts, make sure that for each one, the fixed buckle **14** is fully clicked into its catch **15**.

The belts are then locked and unlocked in the same way as the front seats.

SEAT BELTS

Access to the last row

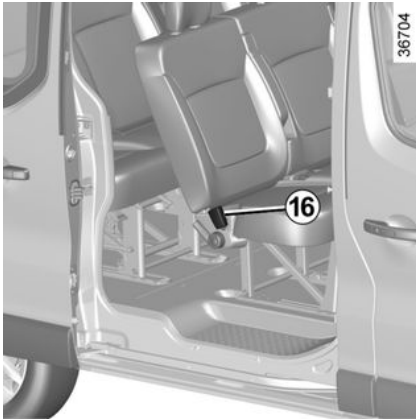

To facilitate access to the last row of seats, detach the second row seat belt by unlocking it from its catch **16**. Insert the detached part of the seat belt into the small bar on the fixed part of the belt.

Remember to lock the seat belt in place once more when a passenger is occupying the seat.

Centre seat belts



Rear seat functions → 58



Make sure that the bench seats → 58 are locked in position properly so that the seat belts will operate efficiently.



Unwind the seat belt slowly until the buckle locks into the catch **17**.

SEAT BELTS

Warning

2



- No modification must be made to the originally-fitted restraint system components (seat belts, seats and their mountings). For special operations (e.g. fitting a child seat), please contact an approved dealer.
- Do not use any devices which slacken the belts (e.g. clothes peg, clip, etc.) as a seat belt which is worn too loosely may cause injury in the event of an accident.
- Never wear the shoulder strap under your arm or behind your back.
- Never use the same belt for more than one person and never hold a baby or child on your lap with your seat belt around them.
- The belt should never be twisted.
- Following an accident, have the seat belts checked and replaced if necessary. Always replace your seat belts as soon as they show any signs of wear.
- Make sure that the seat belt buckle is inserted into the appropriate catch.
- Ensure that no objects are placed in the area around the seat belt catch as they could prevent it from being properly secured.
- Make sure the seat belt catch is properly positioned (it should not be hidden away, crushed or flattened by people or objects).

ADDITIONAL SAFETY DEVICES

Methods of restraint in addition to the front seat belts

Depending on the vehicle, they may comprise:

- front seat belt inertia reel pretensioners;
- chest force limiters;
- Airbags driver and passenger front airbags. driver and passenger front airbags.

These systems are designed to act independently or together when the vehicle is subjected to a frontal impact.

Depending on the severity of the impact, the system can cause:

- blocking of the seat belt;
- the seat belt inertia reel pretensioner which is triggered to correct seat belt slack;
- front Airbag.

Pretensioners

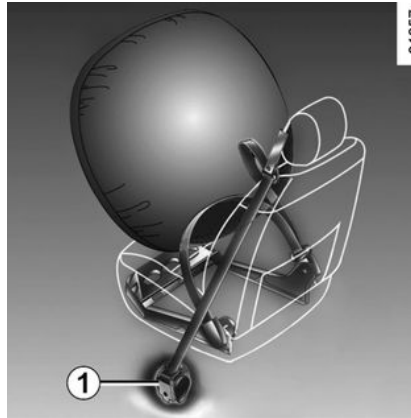

The pretensioners hold the seat belt against the body, holding the occupant more securely against the seat, thus increasing the seat belt's efficiency.

With the ignition on, following a significant frontal impact and depending on the severity of the impact, the system may trigger the seat belt inertia reel pretensioner **1** which instantly retracts the seat belt.

Load limiter

Above a certain severity of impact, this mechanism is used to limit the force of the belt against the body so that it is at an acceptable level.



- Have the entire restraint system checked following an accident.
- No operation whatsoever is permitted on any part of the system (pretensioners, Airbags, computers, wiring) and the system components must not be reused on any other vehicle, even if identical.
- Only qualified personnel from our Network may work on the Airbags; otherwise the system may trigger accidentally and cause injury.
- The electrical trigger system may only be tested by a specially trained technician using special equipment.
- When the vehicle is scrapped, contact an approved dealer for disposal of the pretensioner and Airbags gas generators.

ADDITIONAL SAFETY DEVICES

Driver and passenger front airbags

2



The passenger Airbag airbag only protects the front side passenger, while the front centre passenger is only protected by the seat belt. Please follow the usual safety instructions (wearing the seat belt).

Risk of injury in the event of an accident.



Fitted to the driver and passenger sides.

The "Airbag" mark on the steering wheel and the dashboard (Airbag zone **A**) indicates that this equipment is present.

Each Airbag system consists of:

- an Airbag and gas generator fitted on the steering wheel for the driver and in the dashboard for the passenger;
- an electronic unit for monitoring the system controlling the gas generator electrical trigger;
- a single  warning light on the instrument panel.

Operation



The Airbag system uses pyrotechnic principles. This explains why, when the airbag inflates, it will generate heat, produce smoke (this does not mean that a fire is about to start) and make a banging noise. In a situation where an Airbag is required, it will inflate immediately and this may cause some minor, superficial grazing to the skin or other problems.

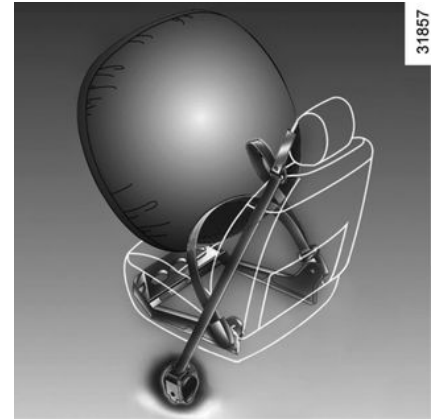

This system is only operational when the ignition is switched on.

In the event of a severe **frontal** impact, the Airbags inflate rapidly, cushioning the impact of the driver's head and chest against the steering wheel and of the front passenger against the dashboard. The airbags then deflate immediately so that the passengers are not in any way hindered from leaving the vehicle;

ADDITIONAL SAFETY DEVICES

Operating faults

53666

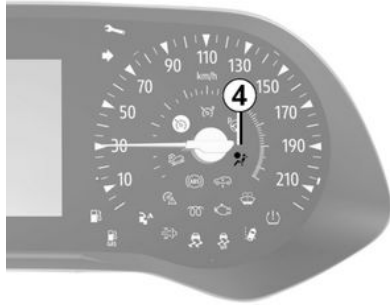

The warning light **4**  will light up on the instrument panel when the ignition is switched on and then go out after a few seconds.

If it does not light up when the ignition is switched on, or if it lights up when the engine is running, this indicates a fault in the system.

Contact your approved Dealer as soon as possible; Your protection will be reduced until this fault is rectified.

47760

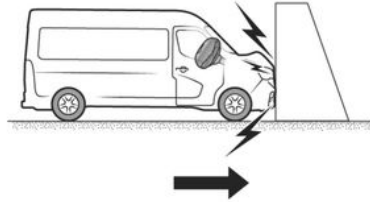

The following cases trigger the pretensioners or Airbags.

In a frontal impact against a rigid (non-deformable) surface at an impact speed equal to or greater than 16 mph (25 km/h).

47763

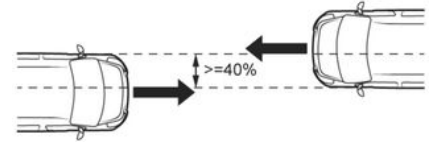

In the event of a frontal impact with another vehicle of an equivalent or higher category, with an impact area equal to or greater than 40%, where the speed of both vehicles is equal to or greater than 35 mph (56 km/h).

ADDITIONAL SAFETY DEVICES

2

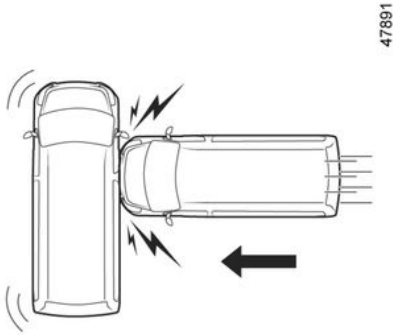

In a side impact with another vehicle of an equivalent or higher category, at an impact speed equal to or greater than 31 mph (50 km/h).

47891



47767

The pretensioners or Airbags may be triggered by:

- an impact underneath the vehicle (e.g. pavement kerb);
- potholes;
- a fall or a hard landing;
- stones;
- ...

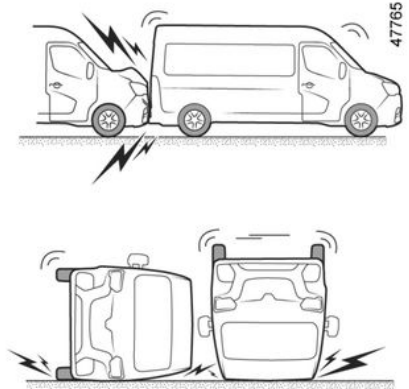

47765

The pretensioners or Airbags may not be triggered by:

- a rear impact, however severe;
- the vehicle overturning;

ADDITIONAL SAFETY DEVICES

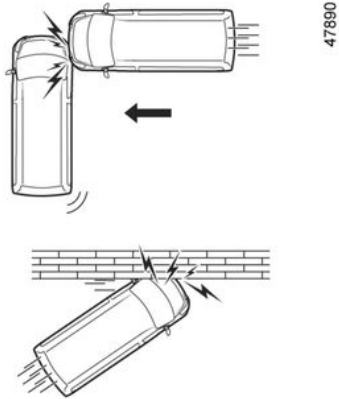

- side impact at the front or rear of the vehicle;
- frontal impact against an obstacle with a sharp angle;
- ...

All of the warnings below are given so that the Airbag is not obstructed in any way when it is inflated and also to prevent the risk of serious injuries caused by items which may be dislodged when it inflates.

ADDITIONAL SAFETY DEVICES

Devices complementary to the front seat belt: warning in relation to airbags

2



Warnings in relation to the driver's Airbag

- Do not modify the steering wheel or the boss.
- Do not cover the steering wheel boss under any circumstances.
- Do not attach any objects (badge, logo, watch, telephone cradle, etc.) to the steering wheel boss.
- The steering wheel must not be removed (except by qualified personnel from our Network).
- Do not sit too close to the steering wheel: adopt a driving position whereby your arms are slightly bent → 63. This will allow sufficient space for the airbag to deploy correctly and be fully effective.

Warnings in relation to the passenger Airbag

- Do not attach or glue any objects (badge, logo, clock, telephone holder, etc.) to the dashboard on or near the Airbag.
- Do not place anything between the dashboard and the passenger (animal, umbrella, walking stick, parcels, etc.).
- The passenger must not put his or her feet on the dashboard or seat as there is a risk that serious injuries may be sustained. As a general rule, parts of the body should be kept away from the dashboard (knees, hands, head, etc.).
- the devices in addition to the front passenger seat belt should be reactivated as soon as a child seat is removed, to ensure the protection of the passenger in the event of an impact.

A REAR-FACING CHILD SEAT MUST NOT BE FITTED TO THE FRONT PASSENGER SEAT UNLESS THE ADDITIONAL RESTRAINT SYSTEMS ARE DEACTIVATED → 128.

ADDITIONAL SAFETY DEVICES

Methods of restraint in addition to the rear seat belts

Load limiter

Above a certain severity of impact, this mechanism is used to limit the force of the belt against the body so that it is at an acceptable level.



- Have the entire restraint system checked following an accident.
- No operation whatsoever is permitted on any part of the system (pretensioners, Airbags, computers, wiring) and the system components must not be reused on any other vehicle, even if identical.
- Only qualified personnel from our Network may work on the Airbags; otherwise the system may trigger accidentally and cause injury.
- The electrical trigger system may only be tested by a specially trained technician using special equipment.
- When the vehicle is scrapped, contact an approved dealer for disposal of the pretensioner and Airbags gas generators.

Side protection devices

Side airbags

These Airbags may be fitted to individual seats and are deployed at the

sides of the seats (door side) to protect the occupants in the event of a severe side impact.

Curtain airbags

These are Airbags fitted to each upper side of the vehicle. They deploy along the front door side windows to protect occupants in the event of a severe side impact.

ADDITIONAL SAFETY DEVICES

2



Warning related to the side airbag Airbag

– Fitting seat covers:

seats equipped with an Airbags require covers specifically designed for your vehicle. Contact an approved dealer to find out if these covers are available. The use of any covers other than those designed for your vehicle (including those designed for another vehicle) may affect the operation of the Airbags and reduce your protection.

– Do not place any accessories, objects or even pets between the seatback, the door and the internal fittings. Do not cover the seatback with objects such as clothes or accessories. This may prevent the airbag from operating correctly or cause injury when the Airbag is deployed.

– No work or modification whatsoever may be carried out on the seat or internal fittings, except by qualified personnel from our Network.

ADDITIONAL SAFETY DEVICES

Additional methods of restraint

All of the warnings below are given so that the Airbags not obstructed in any way when it is inflated and also to prevent the risk of serious injuries caused by items which may be dislodged when it inflates.



The Airbag is designed to complement the action of the seat belt. Both the Airbag and the seat belt are integral parts of the same protection system. It is therefore essential to wear seat belts at all times. If seat belts are not worn, the occupants are exposed to the risk of serious injury in the event of an accident. It may also increase the risk of minor superficial injuries occurring when the Airbag is deployed, although such minor injuries are always possible with airbags.

If the vehicle should overturn or suffer a rear impact, however severe, the pretensioners and Airbags are not always triggered. Shocks to the underbody of the vehicle, from pavements, potholes, stones etc. can all trigger these systems.

- Work and modifications on the complete Airbag system (Airbags, pretensioners, ECU, wiring harness, etc.), are **strictly prohibited** (except by qualified Network personnel).
- To ensure that the system is in good working order and to avoid accidental triggering of the system which may cause injury, only qualified Network personnel may work on the Airbag system.
- As a safety precaution, have the Airbag system checked if your vehicle has been involved in an accident, or is stolen or broken into.
- When selling or lending the vehicle, inform the new purchaser of these conditions when handing over this vehicle user manual.
- When scrapping your vehicle, contact your approved dealer for disposal of the gas generator(s).

CHILD SAFETY

General information

2

Carrying children

Please ensure that you comply with the legislation of your country.

Children, and adults, must be correctly seated and strapped in for all journeys. The children being carried in your vehicle are your responsibility.

A child is not a miniature adult. Children are at risk of specific injuries as their muscles and bones have not yet finished growing. The seat belt alone would not provide suitable protection. Use an approved child seat and ensure you use it correctly.



To prevent the doors being opened, use the "Child lock" feature → 41.



A collision at 31 mph (50 km/h) is the same as falling a distance of 10 metres. Transporting a child without a restraint is the equivalent of allowing him or her to play on a fourth-floor balcony without railings. Never travel with a child held in your arms. In the event of an accident, you will not be able to keep hold of the child, even if you yourself are wearing a seat belt. If your vehicle has been involved in a road accident, replace the child seat and have the seat belts and Isofix anchorage points checked.



Driver's responsibility when parking or stopping the vehicle

Never leave an animal, child or adult who is not self-sufficient alone in your vehicle, even for a short time. They may pose a risk to themselves or to others by starting the engine, activating equipment such as the electric windows or by locking the doors. Also, in hot and/or sunny weather, please remember that the temperature inside the passenger compartment increases very quickly. **RISK OF DEATH OR SERIOUS INJURY.**

Using a child seat

The level of protection offered by the child seat depends on its ability to restrain your child and on its installation. Incorrect installation compromises the protection it offers the child in the event of harsh braking or an impact.

Before purchasing a child seat, check that it complies with the regulations for the country you are in and that it can be fitted in your vehicle. Consult an ap-

CHILD SAFETY

proved Dealer to find out which seats are recommended for your vehicle.

Before fitting a child seat, read the manual and respect its instructions. If you experience any difficulties during installation, contact the manufacturer of the equipment. Keep the instructions with the seat.



Never leave a child unattended in the vehicle.

Check that your child is always strapped in and

that the belt or safety harness used is correctly set and adjusted. Avoid wearing bulky clothing which could cause the belts to slacken → 63.

Never let your child put their head or arms out of the window.

Check that the child is in the correct position for the entire journey, especially if asleep.



Set a good example by always fastening your seat belt and teaching your child:

- to strap themselves in correctly;
- to always get in and out of the car at the kerb, away from busy traffic.

Do not use a second-hand child seat or one without an instruction manual.

Check that there are no objects in the vicinity of the child seat which could impede its operation.

Choosing a child seat

Rear-facing child seats



A baby's head is, proportionally, heavier than that of an adult and its neck is very fragile. Transport the child in this position as long as possible (until the age of 2 at the very least). It supports both the head and the neck.

Choose a bucket type seat for best side protection and change it as soon as the child's head is higher than the shell.

CHILD SAFETY

Forward-facing child seats

2



31233

Up to 18 kg or 4 years, the child may travel on a forward-facing seat. Choose your seat according to the child's size: their head and abdomen are the areas which must be most protected. A forward-facing child seat which is firmly attached to the vehicle will reduce the risk of impact to the head. Ensure your child travels in a forward-facing seat with a harness or buckle for as long as their size permits.

Choose a bucket type seat for optimum side protection.

Boosters



31234

From 15 kg or 4 years, the child can travel using a booster seat which will enable the seat belt to be adapted to suit the size and shape. The booster seat cushion must be fitted with guides to position the seat belt on the child's thighs rather than the stomach. It is recommended that you use a seatback which can be adjusted in terms of height to position the seat belt in the centre of the shoulder. It must never rest on the neck or on the arm.

Choose a bucket type seat for optimum side protection.

Choosing a child seat mounting

There are two ways to attach child seats: using the seat belt or using the Isofix system.

Attachment using the ISOFIX system

Authorised Isofix child seats are approved in accordance with regulation ECE-R44 in one of the three following cases:

- Universal Isofix 3-point forward-facing seat;
- Semi-universal Isofix 2-point seat;
- specific.

For the latter two, check that your child seat can be installed by consulting the list of compatible vehicles.

Attach the child seat with the Isofix locks, if these are provided. The Isofix system allows quick, easy and safe fitting.

The Isofix system consists of 2 rings and, in some cases, a third ring.

CHILD SAFETY

42559

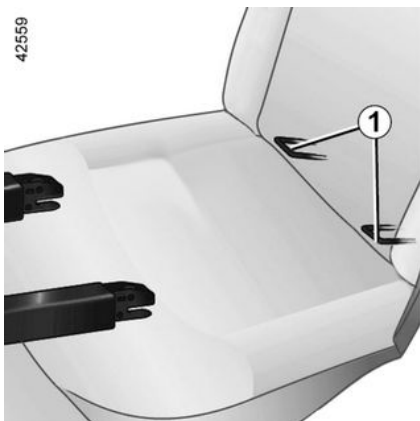

The two rings **1**, identified by a  mark, are located between the seat-back and the seat base



No modifications must be made to the component parts of the original fitted restraint system (seat belts, Isofix, seats and their mountings).



The Isofix anchorage points have been exclusively designed for child seats with the Isofix system. Never fit a different type of child seat, seat belt or other objects to these fittings. Check that nothing is obstructing the anchorage points. If your vehicle has been involved in a road accident, have the Isofix anchorage points checked and replace your child seat.

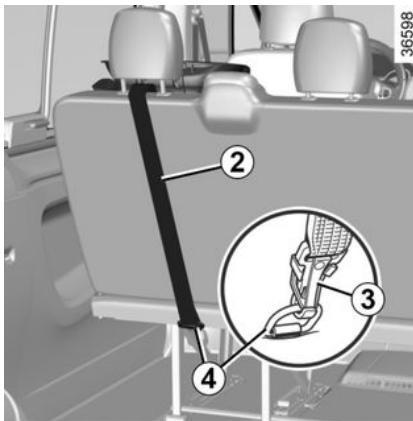

Front-facing seat mounting ring for rear side seats

The third ring is used to attach the upper strap on some child seats.

- Set the headrest to the raised position or remove it;
- pass the belt **2** (supplied with the seat) between the two rear headrest rods;
- the hook **3** **must** be attached to the

ring **4** marked by the  symbol behind the seat;

- pull the belt so that the child seat comes into contact with the vehicle seatback.



Check that the seatback of the forward-facing child seat is in contact with the seatback of the vehicle seat. In this case, the child seat may not always rest on the seat base of the vehicle seat.

Attachment by seat belt

The seat belt must be adjusted in order to ensure it works in the event of sudden braking or impact.

2

CHILD SAFETY

Ensure that the strap paths indicated by the child seat manufacturer are observed.

Always check that the seat belt is correctly fastened by pulling it up, then pulling it out fully whilst pressing on the child seat.

Check that the seat is correctly held by moving it from side to side and back to front: the seat should remain firmly fixed.

Check that the child seat has not been installed at an angle and that it is not resting against a window.



Do not use the child seat if it risks unfastening the seat belt restraining it: the base of the seat must not rest on the buckle and/or catch of the seat belt.



The seat belt must never be twisted or the tension relieved. Never pass the shoulder strap under the arm or behind the back. Check that the seat belt has not been damaged by sharp edges. If the seat belt does not operate normally, it will not protect the child. Consult an approved dealer. Do not use this seat until the seat belt has been repaired.



No modifications must be made to the component parts of the originally fitted restraint system (seat belts, Isofix, seats and their mountings).

CHILD SEATS

Fitting a child seat, general information

Some seats are not suitable for fitting child seats. The diagram and installation table indicate where to attach a child seat → **88**.

The types of child seats indicated may not be available. Before using a different child seat, check with the manufacturer that it can be fitted.



Make sure the child seat or the child's feet do not prevent the front seat from locking correctly

→ 54.

Check that when installing the child seat in the vehicle it is not at risk of coming loose from its base.

If you have to remove the headrest, check that it is correctly stored so that it does not come loose under harsh braking or impact.

Always attach the child seat to the vehicle even if it is not in use so that it does not come loose under harsh braking or impact.

In the front seat

The laws concerning children travelling in the front passenger seat differ in every country. Consult the current legislation and follow the indications on the installation table diagram → **88**.

Before fitting a child seat in this seat (if authorised):

- lower the seat belt as far as possible;
- move the seat as far back as possible;
- gently tilt the seatback away from the vertical position (approximately 25°);
- on equipped vehicles, raise the seat base as far as possible.

Always fully raise the seat headrest so that it does not interfere with the child seat → **54**.

After installing the child seat, when this is possible, you can move the vehicle seat forward if necessary (so as to leave enough space in the rear seats for passengers or other child seats). For a rear-facing child seat, do not let it touch the dashboard or move it to the furthest forward position.

Do not change other settings after installing the child seat.



RISK OF DEATH OR SERIOUS INJURY: before fitting a child seat in the front passenger seat, check that the Airbag has been deactivated → **128**.

In the rear side seat

A carrycot can be installed across the vehicle and will take up at least two seats.

Position the child with his or her feet nearest the door.

In order to install a rear-facing child seat, move the front seat as far forward as possible, then move the front seat back as far as it will go, without allowing it to come into contact with the child seat.

For the safety of the child in the forward-facing position:

- do not push the seat in front of the child back further than halfway along its runners;
- do not recline the seatback too far (maximum of 25°) and raise the seat as much as possible.

In all situations, remove the headrest of the rear seat on which the child seat

CHILD SEATS

is positioned → 58. This must be done before fitting the child seat.

Check that the forward-facing child seat is resting against the back of the vehicle seat.

In rear centre seat

Check that the belt is suitable for securing your child seat. Consult an approved dealer.



A child seat with a floor support must never be installed on the rear centre seat.

RISK OF DEATH OR SERIOUS INJURY.



Fit the child seat in a rear seat wherever possible.

Installing a booster seat (group 2 or 3)

Check that the seat belt → 63 operates (winds) correctly.

Adjust the seat belt by positioning:

– the shoulder strap on the child's shoulder without it touching their neck;

– the lap belt so that it lies flat on the thighs and against the pelvis.

If necessary, adjust the position of the vehicle seat.

CHILD SEATS

Attachment by seat belt

2

2-seater van version

Fitting diagram



59585

CHILD SEATS



Check the status of the airbag before fitting a child seat or allowing a passenger to use the seat.



Seat not suitable for fitting child seats.

Child seat attached using the belt



Seat equipped for attaching a "universal" approved seat using a seatbelt.

B2: seat enabling a child seat with "B2" approval to be attached by seat belt.



Check that your child is always strapped in and that the belt or safety harness used is correctly set and adjusted
→ 63.

If necessary, adjust the seat position accordingly.



Using a child safety system which is not approved for this vehicle will not properly protect the baby or child. They risk serious or even fatal injury.



RISK OF DEATH OR SERIOUS INJURY: before fitting a rear facing child seat on the front passenger seat, check that the Airbag has been deactivated → 128.

CHILD SEATS

2-seater van version: installation table

The table below summarises the information already shown on the previous diagram in order to ensure the regulations in force are respected.

2-seater van versions				
Type of child seat	Weight of the child	Front passenger seat(s)		
		With single passenger seat	With two-seater bench seat	
			Centre seat	Side seat
Shell seat/rear-facing seat Groups 0, 0+ and 1	< to 13 kg and 9 to 18 kg	U (2)	X	U (2)
Forward-facing seat Group 1	9 to 18 kg	U (1)	X	U (1)
Booster seat Groups 2 and 3	15 to 25 kg and 22 to 36 kg	U / B2 (1)	X	U / B2 (1)

X = Seat which does not allow a child seat of this type to be fitted.

U = Seat allowing a child seat with "Universal" approval to be attached by seat belt: check that it can be fitted.

B2 = Seat enabling a child seat with "B2" approval to be attached by seat belt: check that it can be fitted.

(1) To fit a forward-facing child seat, position the back of the child seat so that it is in contact with the vehicle seatback. Raise the headrest. Raise the seat to the maximum and position it as far back as possible, tilting the seatback slightly (approximately 25°).



(2) RISK OF DEATH OR SERIOUS INJURY: before fitting a rear-facing child seat in the front passenger seat, check that the Airbag has been deactivated → 128.

CHILD SEATS

3-seater van version

2

Fitting diagram



59586

CHILD SEATS



Check the status of the airbag before fitting a child seat or allowing a passenger to use the seat.



Seat not suitable for fitting child seats.

Child seat attached using the belt



Seat equipped for attaching a "universal" approved seat using a seatbelt.

B2: seat enabling a child seat with "B2" approval to be attached by seat belt.



Check that your child is always strapped in and that the belt or safety harness used is correctly set and adjusted
→ 63.

If necessary, adjust the seat position accordingly.



Using a child safety system which is not approved for this vehicle will not properly protect the baby or child. They risk serious or even fatal injury.



RISK OF DEATH OR SERIOUS INJURY: before fitting a rear facing child seat on the front passenger seat, check that the Airbag has been deactivated → 128.

CHILD SEATS

3-seater van version: installation table

2

The table below summarises the information already shown on the previous diagram in order to ensure the regulations in force are respected.

3-seater van versions				
Type of child seat	Weight of the child	Front passenger seat(s)		
		With single passenger seat	With two-seater bench seat	
			Centre seat	Side seat
Shell seat/rear-facing seat Groups 0, 0+ and 1	< to 13 kg and 9 to 18 kg	U (2)	X	U (2)
Forward-facing seat Group 1	9 to 18 kg	U (1)	X	U (1)
Booster seat Groups 2 and 3	15 to 25 kg and 22 to 36 kg	U / B2 (1)	X	U / B2 (1)

X = Seat which does not allow a child seat of this type to be fitted.

U = Seat allowing a child seat with "Universal" approval to be attached by seat belt: check that it can be fitted.

B2 = Seat enabling a child seat with "B2" approval to be attached by seat belt: check that it can be fitted.

(1) To fit a forward-facing child seat, position the back of the child seat so that it is in contact with the vehicle seatback. Raise the headrest. Raise the seat to the maximum and position it as far back as possible, tilting the seatback slightly (approximately 25°).



(2) RISK OF DEATH OR SERIOUS INJURY: before fitting a rear-facing child seat in the front passenger seat, check that the Airbag has been deactivated → 128.

CHILD SEATS

5-seater Combi

2

Fitting diagram



59584

CHILD SEATS



Check the status of the airbag before fitting a child seat or allowing a passenger to use the seat.

Child seat attached using the belt



Seat equipped for attaching a "universal" approved seat using a seatbelt.



Seat not suitable for fitting child seats.

B2: seat enabling a child seat with "B2" approval to be attached by seat belt.

B3: seat enabling a child seat with "B3" approval to be attached by seat belt.



Check that your child is always strapped in and that the belt or safety harness used is correctly set and adjusted → 63.
If necessary, adjust the seat position accordingly.



RISK OF DEATH OR SERIOUS INJURY: before fitting a rear facing child seat on the front passenger seat, check that the Airbag has been deactivated → 128.



Using a child safety system which is not approved for this vehicle will not properly protect the baby or child. They risk serious or even fatal injury.

CHILD SEATS

5-seater Combi version: installation table

The table below summarises the information already shown on the previous diagram in order to ensure the regulations in force are respected.

5-seater Combi version				
Type of child seat	Weight of the child	Front passenger seat	Rear side seat	Rear centre seat
Carrycot fitted across the vehicle Group 0	< 10 kg	X	U (3)	U (3)
Rear-facing shell seat Groups 0 and 0+	< 13 kg	U (1) (2)	U (4)	U (4)
Rear-facing seat Groups 0+ and 1	< to 13 kg and 9 to 18 kg	U (1) (2)	U (4)	U (4)
Forward-facing seat Group 1	9 to 18 kg	U (2)	U (5)	U (5)
Booster seat Groups 2 and 3	15 to 25 kg and 22 to 36 kg	U / B2 (2)	U / B2 / B3 (5)	U / B2 (5)

X = Seat not suitable for fitting this type of child seat.

U = Seat allowing a child seat with "Universal" approval to be attached by seat belt: check that it can be fitted.

B2 = Seat allowing a child seat with "B2" approval to be attached by seat belt: check that it can be fitted.

B3 = Seat allowing a child seat with "B3" approval to be attached by seat belt: check that it can be fitted.



(1) RISK OF DEATH OR SERIOUS INJURY: before fitting a rear-facing child seat in the front passenger seat, check that the Airbag has been deactivated → 128.

CHILD SEATS

- (2) Raise the seat to the maximum and position it as far back as possible, tilting the seatback slightly (approximately 25°).
- (3) A carrycot can be installed across the vehicle and will take up at least two seats. Position the child with his or her feet nearest the door.
- (4) In order to install a rear-facing child seat, move the front seat as far forward as possible, then move the front seat back as far as it will go, without allowing it to come into contact with the child seat.
- (5) To fit a forward-facing child seat, position the back of the child seat in contact with the vehicle seatback. In all situations, remove the rear headrest of the seat on which the child seat is positioned. This action must be performed before fitting the child seat → 58. Do not push the seat in front of the child more than halfway back on its runners and do not recline the seatback more than 25°.

CHILD SEATS

6-seater Combi

2

Fitting diagram



59583

CHILD SEATS



Check the status of the airbag before fitting a child seat or allowing a passenger to use the seat.

Child seat attached using the belt



Seat equipped for attaching a "universal" approved seat using a seatbelt.



Seat not suitable for fitting child seats.

B2: seat which allows a child seat with "B2" approval to be attached by seat belt.

B3: seat allowing a child seat with "B3" approval to be attached by seat belt.



When a child seat is installed in the front passenger seat, it is recommended not to use the middle seat and to leave it unoccupied.



Check that your child is always strapped in and that the belt or safety harness used is correctly set and adjusted → 63.

If necessary, adjust the seat position accordingly.



RISK OF DEATH OR SERIOUS INJURY: before fitting a rear facing child seat on the front passenger seat, check that the Airbag has been deactivated → 128.



Using a child safety system which is not approved for this vehicle will not properly protect the baby or child. They risk serious or even fatal injury.

CHILD SEATS

6-seater Combi version: installation table

The table below summarises the information shown on the following diagram in order to ensure the regulations in force are respected.

6-seater Combi version					
Type of child seat	Weight of the child	Front seat		Rear seat	
		Central passenger	Side passenger	Side	Central
Carrycot fitted across the vehicle Group 0	< 10 kg	X	X	U (2)	U (2)
Rear-facing shell seat Groups 0 and 0+	< 13 kg	X	U (1)	U (3)	U (3)
Rear-facing seat Groups 0+ and 1	< to 13 kg and 9 to 18 kg	X	U (1)	U (3)	U (3)
Forward-facing seat Group 1	9 to 18 kg	X	U	U (4)	U (4)
Booster seat Groups 2 and 3	15 to 25 kg and 22 to 36 kg	X	U / B2	U / B2 / B3 (4)	U (4)

X = Seat not suitable for fitting this type of child seat.

U = Seat allowing a child seat with "Universal" approval to be attached by seat belt: check that it can be fitted.

B2 = Seat allowing a child seat with "B2" approval to be attached by seat belt: check that it can be fitted.

B3 = Seat allowing a child seat with "B3" approval to be attached by seat belt: check that it can be fitted.

CHILD SEATS



(1) RISK OF DEATH OR SERIOUS INJURY: before fitting a rear-facing child seat in the front passenger seat, check that the Airbag has been deactivated → 128.

(2) A carrycot can be installed across the vehicle and will take up at least two seats. Position the child with his or her feet nearest the door.

(3) In order to install a rear-facing child seat, move the front seat as far forward as possible, then move the front seat back as far as it will go, without allowing it to come into contact with the child seat.

(4) To fit a forward-facing child seat, position the back of the child seat in contact with the vehicle seatback. In all situations, remove the rear headrest of the seat on which the child seat is positioned. This action must be performed before fitting the child seat → 58. Do not push the seat in front of the child more than halfway back on its runners and do not recline the seatback more than 25°.

CHILD SEATS

Combi/8-seater bus

2

Fitting diagram



59582

CHILD SEATS



Check the status of the airbag before fitting a child seat or allowing a passenger to use the seat.

Child seat attached using the belt



Seat equipped for attaching a "universal" approved seat using a seatbelt.



Seat not suitable for fitting child seats.

B2: seat which allows a child seat with "B2" approval to be attached by seat belt.

B3: seat allowing a child seat with "B3" approval to be attached by seat belt.



Check that your child is always strapped in and that the belt or safety harness used is correctly set and adjusted
→ 63.

If necessary, adjust the seat position accordingly.



RISK OF DEATH OR SERIOUS INJURY: before fitting a rear facing child seat on the front passenger seat, check that the Airbag has been deactivated → 128.



Using a child safety system which is not approved for this vehicle will not properly protect the baby or child. They risk serious or even fatal injury.

CHILD SEATS

8-seater Combi/Bus version: installation table

The table below summarises the information already shown on the previous diagram in order to ensure the regulations in force are respected.

8-seater Bus/Combi version						
Type of child seat	Weight of the child	Front passenger seat	Rear seat			
			2nd row side seats	2nd row centre seat	3rd row side seats	3rd row centre seat
Carrycot fitted across the vehicle Group 0	< 10 kg	X	U (3)	U (3)	U (3)	U (3)
Rear-facing shell seat Groups 0 and 0+	< 13 kg	U (1) (2)	U (4)	U (4)	U (4)	U (4)
Rear-facing seat Groups 0+ and 1	< to 13 kg and 9 to 18 kg	U (1) (2)	U (4)	U (4)	U (4)	U (4)
Forward-facing seat Group 1	9 to 18 kg	U (2)	U (5)	U (5)	U (5)	U (5)
Booster seat Groups 2 and 3	15 to 25 kg and 22 to 36 kg	U / B2 (2)	U / B2 / B3 (5)	U / B2 / B3 (5)	U / B2 / B3 (5)	U / B2 (5)

X = Seat not suitable for fitting this type of child seat.

U = Seat allowing a child seat with "Universal" approval to be attached by seat belt: check that it can be fitted.

B2 = Seat allowing a child seat with "B2" approval to be attached by seat belt: check that it can be fitted.

B3 = Seat allowing a child seat with "B3" approval to be attached by seat belt: check that it can be fitted.

CHILD SEATS



(1) RISK OF DEATH OR SERIOUS INJURY: before fitting a rear-facing child seat in the front passenger seat, check that the Airbag has been deactivated → 128.

- (2)** Raise the seat to the maximum and position it as far back as possible, tilting the seatback slightly (approximately 25°).
- (3)** A carrycot can be installed across the vehicle and will take up at least two seats. Position the child with his or her feet nearest the door.
- (4)** In order to install a rear-facing child seat, move the front seat as far forward as possible, then move the front seat back as far as it will go, without allowing it to come into contact with the child seat.
- (5)** To fit a forward-facing child seat, position the back of the child seat in contact with the vehicle seatback. In all situations, remove the rear headrest of the seat on which the child seat is positioned. This action must be performed before fitting the child seat → 58. Do not push the seat in front of the child more than halfway back on its runners and do not recline the seatback more than 25°.

CHILD SEATS

Combi/9-seater bus

2

Fitting diagram



59581

CHILD SEATS



Check the status of the airbag before fitting a child seat or allowing a passenger to use the seat.

Child seat attached using the belt



Seat equipped for attaching a "universal" approved seat using a seatbelt.



Seat not suitable for fitting child seats.

B2: seat which allows a child seat with "B2" approval to be attached by seat belt.

B3: seat enabling a child seat with "B3" approval to be attached by seat belt.



When a child seat is installed in the front passenger seat, it is recommended not to use the middle seat and to leave it unoccupied.



Check that your child is always strapped in and that the belt or safety harness used is correctly set and adjusted → 63.

If necessary, adjust the seat position accordingly.



RISK OF DEATH OR SERIOUS INJURY: before fitting a rear facing child seat on the front passenger seat, check that the Airbag has been deactivated → 128.



Using a child safety system which is not approved for this vehicle will not properly protect the baby or child. They risk serious or even fatal injury.

CHILD SEATS

9-seater Combi/Bus version: installation table

The table below summarises the information shown on the following diagram in order to ensure the regulations in force are respected.

9-seater Bus/Combi version							
Type of child seat	Weight of the child	Front seat		Rear seat			
		Central passenger	Side passenger	2nd row side seats	2nd row centre seat	3rd row side seats	3rd row centre seat
Carrycot fitted across the vehicle Group 0	< 10 kg	X	X	U (2)	U (2)	U (2)	U (3)
Rear-facing shell seat Groups 0 and 0+	< 13 kg	X	U (1)	U (3)	U (3)	U (3)	U (3)
Rear-facing seat Groups 0+ and 1	< to 13 kg and 9 to 18 kg	X	U (1)	U (4)	U (3)	U (3)	U (3)
Forward-facing seat Group 1	9 to 18 kg	X	U	U (4)	U (4)	U (4)	U (4)
Booster seat Groups 2 and 3	15 to 25 kg and 22 to 36 kg	X	U / B2	U / B2 / B3 (4)	U / B2 (4)	U / B2 / B3 (4)	U / B2 (4)

X = Seat not suitable for fitting this type of child seat.

U = Seat allowing a child seat with "Universal" approval to be attached by seat belt: check that it can be fitted.

B2 = Seat allowing a child seat with "B2" approval to be attached by seat belt: check that it can be fitted.

B3 = Seat allowing a child seat with "B3" approval to be attached by seat belt: check that it can be fitted.

CHILD SEATS



(1) RISK OF DEATH OR SERIOUS INJURY: before fitting a rear-facing child seat in the front passenger seat, check that the Airbag has been deactivated → 128.

(2) A carrycot can be installed across the vehicle and will take up at least two seats. Position the child with his or her feet nearest the door.

(3) In order to install a rear-facing child seat, move the front seat as far forward as possible, then move the front seat back as far as it will go, without allowing it to come into contact with the child seat.

(4) To fit a forward-facing child seat, position the back of the child seat in contact with the vehicle seatback. In all situations, remove the rear headrest of the seat on which the child seat is positioned. This action must be performed before fitting the child seat → 58. Do not push the seat in front of the child more than halfway back on its runners and do not recline the seatback more than 25°.

CHILD SEATS

Attachment using the ISOFIX system

2

5-seater Combi version

Fitting diagram

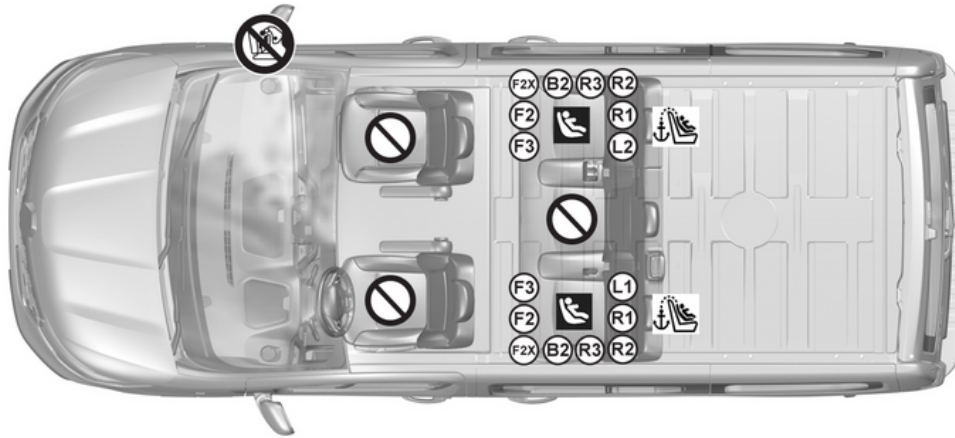

67683

CHILD SEATS



Seat which does not allow a child seat to be fitted.

Child seat attached using the mounting Isofix



Seat which allows an Isofix child seat to be fitted.



The rear seats are fitted with an anchorage point which allows a forward-facing ISOFIX child seat with universal approval to be attached. The anchorage points are located in the luggage compartment and are visible.

The size of the ISOFIX child seat is indicated by a letter:

- F3 [A], F2 [B], F2X [B1]: for forward-facing seats in Group 1 (9 to 18 kg);
- R3 [C]: rear-facing seats in Group 1 (9 to 18 kg);
- R2 [D], R1 [E]: rear-facing seats or shell seats in Group 0 or 0+ (less than 13 kg);
- L1 [F], L2 [G]: carrycots in Group 0 (less than 10 kg);
- B2, B3: boosters in groups 2 and 3 (15 to 25 kg and 22 to 36 kg).



Using a child safety system which is not approved for this vehicle will not properly protect the baby or child. They risk serious or even fatal injury.



Check that your child is always strapped in and that the belt or safety harness used is correctly set and adjusted
→ 68.
If necessary, adjust the seat position accordingly.

CHILD SEATS

5-seater Combi version: installation table

The table below summarises the information already shown on the previous diagram in order to ensure the regulations in force are respected.

5-seater Combi version					
Type of child seat	Weight of the child	Seat size ISOFIX [Height]	Front passenger seat	Rear side seat	Rear centre seat
Carrycot fitted across the vehicle Group 0	< 10 kg	L1 [F], L2 [G]	X	IL (1)	X
Rear-facing shell seat Groups 0 and 0+	< 13 kg	R1 [E]	X	IL (2)	X
Rear-facing seat Groups 0+ and 1	< to 13 kg and 9 to 18 kg	R3 [C], R2 [D]	X	IL (2)	X
Forward-facing seat Group 1	9 to 18 kg	F3 [A], F2 [B], F2X [B1]	X	IUF-IL (3)	X
Booster seat Groups 2 and 3	15 to 25 kg and 22 to 36 kg	B2	X	IUF-IL (3)	X
		B3	X	IUF-IL (3)	X
I-Size seat	Rear-facing seat		X	X	X
	Forward-facing seat		X	X	X
	Booster seat		X	X	X

X = Seat which does not allow a child seat Isofix to be fitted.

IUF/IL = Seat enabling a child seat with "Universal/Semi-universal or vehicle-specific" approval to be attached by Isofix (on equipped vehicles): check that it can be fitted.

CHILD SEATS

(1) A carrycot can be installed across the vehicle and will take up at least two seats. Position the child with his or her feet nearest the door.

(2) In order to install a rear-facing child seat, move the front seat as far forward as possible, then move the front seat back as far as it will go, without allowing it to come into contact with the child seat.

(3) To fit a forward-facing child seat, position the back of the child seat in contact with the vehicle seatback. In all situations, remove the rear headrest of the seat on which the child seat is positioned. This action must be performed before fitting the child seat → 58. Do not push the seat in front of the child more than halfway back on its runners and do not recline the seatback more than 25°.

CHILD SEATS



Seat which does not allow a child seat to be fitted.

Child seat attached using the mounting Isofix



Seat which allows an Isofix child seat to be fitted.



The rear seats are fitted with an anchorage point which allows a front-facing Isofix child seat with universal approval to be attached. The anchorage points are located in the luggage compartment and are visible.

The size of the Isofix child seat is indicated by a letter:

- F3 [A], F2 [B], F2X [B1]: for forward-facing seats in Group 1 (9 to 18 kg);
- R3 [C]: rear-facing seats in Group 1 (9 to 18 kg);
- R2 [D], R1 [E]: rear-facing seats or shell seats in Group 0 or 0+ (less than 13 kg);
- L1 [F], L2 [G]: carrycots in Group 0 (less than 10 kg);
- **B2, B3**: boosters in groups 2 and 3 (15 to 25 kg and 22 to 36 kg).



Using a child safety system which is not approved for this vehicle will not properly protect the baby or child. They risk serious or even fatal injury.



Check that your child is always strapped in and that the belt or safety harness used is correctly set and adjusted
→ 68.
If necessary, adjust the seat position accordingly.

CHILD SEATS

6-seater Combi version: installation table

The table below summarises the information already shown on the previous diagram in order to ensure the regulations in force are respected.

6-seater Combi version						
Type of child seat	Weight of the child	Seat size Isofix [Height]	Front seat		Rear seat	
			Central passenger	Side passenger	Side	Central
Carrycot fitted across the vehicle Group 0	< 10 kg	L1 [F], L2 [G]	X	X	X	X
Rear-facing shell seat Groups 0 and 0+	< 13 kg	R1 [E]	X	X	IL (2)	X
Rear-facing seat Groups 0+ and 1	< to 13 kg and 9 to 18 kg	R3 [C], R2 [D]	X	X	X	X
Forward-facing seat Group 1	9 to 18 kg	F3 [A], F2 [B], F2X [B1]	X	X	IUF-IL (3)	X
Booster seat Groups 2 and 3	15 to 25 kg	B2	X	X	IUF-IL (3)	X
	22 to 36 kg	B3	X	X	IUF-IL (3)	X
I-Size seat	Rear-facing seat		X	X	X	X
	Rear-facing seat		X	X	X	X
	Booster seat		X	X	X	X

CHILD SEATS

X = Seat which does not allow a child seat Isofix to be fitted.

IUF/IL = Seat enabling a child seat with "Universal/Semi-universal or vehicle-specific" approval to be attached by Isofix (on equipped vehicles): check that it can be fitted.

(1) A carrycot can be installed across the vehicle and will take up at least two seats. Position the child with his or her feet nearest the door.

(2) In order to install a rear-facing child seat, move the front seat as far forward as possible, then move the front seat back as far as it will go, without allowing it to come into contact with the child seat.

(3) To fit a forward-facing child seat, position the back of the child seat in contact with the vehicle seatback. In all situations, remove the rear headrest of the seat on which the child seat is positioned. This action must be performed before fitting the child seat → **58**. Do not push the seat in front of the child more than halfway back on its runners and do not recline the seatback more than 25°.

CHILD SEATS

8-seater Bus/Combi version

2

Fitting diagram



67685

CHILD SEATS



Seat which does not allow a child seat to be fitted.

Child seat attached using the mounting Isofix



Seat which allows an ISOFIX child seat to be fitted.



The rear seats are fitted with an anchorage point which allows a front-facing Isofix child seat with universal approval to be attached. The anchorage points are located in the luggage compartment and are visible.

The size of the Isofix child seat is indicated by a letter:

- F3 [A], F2 [B], F2X [B1]: for forward-facing seats in Group 1 (9 to 18 kg);
- R3 [C]: rear-facing seats in Group 1 (9 to 18 kg);
- R2 [D], R1 [E]: rear-facing seats or shell seats in Group 0 or 0+ (less than 13 kg);
- L1 [F], L2 [G]: carrycots in Group 0 (less than 10 kg);
- **B2, B3**: boosters in groups 2 and 3 (15 to 25 kg and 22 to 36 kg).



Using a child safety system which is not approved for this vehicle will not properly protect the baby or child. They risk serious or even fatal injury.



Check that your child is always strapped in and that the belt or safety harness used is correctly set and adjusted
→ 68.
If necessary, adjust the seat position accordingly.

CHILD SEATS

8-seater Combi/Bus version: installation table

The table below summarises the information already shown on the previous diagram in order to ensure the regulations in force are respected.

8-seater Bus/Combi version							
Type of child seat	Weight of the child	Seat size Isofix [Height]	Front passenger seat	Rear seat			
				2nd row side seats	2nd row centre seat	3rd row side seats	3rd row centre seat
Carrycot fitted across the vehicle Group 0	< 10 kg	L1 [F], L2 [G]	X	IL (1)	X	X	X
Rear-facing shell seat Groups 0 and 0+	< 13 kg	R1 [E]	X	IL (2)	X	X	X
Rear-facing seat Groups 0+ and 1	< to 13 kg and 9 to 18 kg	R3 [C], R2 [D]	X	IL (2)	X	X	X
Forward-facing seat Group 1	9 to 18 kg	F3 [A], F2 [B], F2X [B1]	X	IUF-IL (3)	X	X	X
Booster seat Groups 2 and 3	15 to 25 kg 22 to 36 kg	B2	X	IUF-IL (3)	X	X	X
		B3	X	IUF-IL (3)	X	X	X
I-Size seat	Rear-facing seat		X	X	X	X	X
	Forward-facing seat		X	X	X	X	X
	Booster seat		X	X	X	X	X

CHILD SEATS

X = Seat which does not allow a child seat Isofix to be fitted.

IUF/IL = Seat enabling a child seat with "Universal/Semi-universal or vehicle-specific" approval to be attached by Isofix (on equipped vehicles): check that it can be fitted.

(1) A carrycot can be installed across the vehicle and will take up at least two seats. Position the child with his or her feet nearest the door.

(2) In order to install a rear-facing child seat, move the front seat as far forward as possible, then move the front seat back as far as it will go, without allowing it to come into contact with the child seat.

(3) To fit a forward-facing child seat, position the back of the child seat in contact with the vehicle seatback. In all situations, remove the rear headrest of the seat on which the child seat is positioned. This action must be performed before fitting the child seat → **58**. Do not push the seat in front of the child more than halfway back on its runners and do not recline the seatback more than 25°.

CHILD SEATS

9-seater Bus/Combi version

2

Fitting diagram

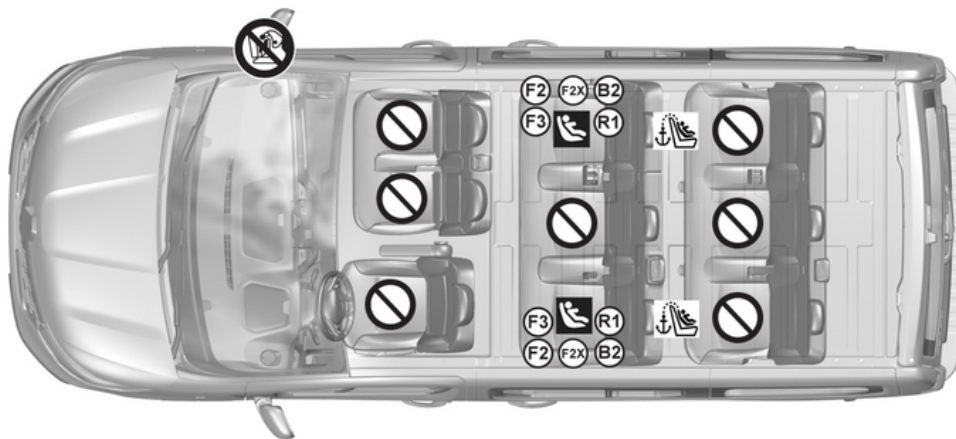

67686

CHILD SEATS



Seat which does not allow a child seat to be fitted.

Child seat attached using the ISOFIX system



Seat which allows an ISOFIX child seat to be fitted.



The rear seats are fitted with an anchorage point which allows a front-facing Isofix child seat with universal approval to be attached. The anchorage points are located in the luggage compartment and are visible.

The size of the Isofix child seat is indicated by a letter:

- F3 [A], F2 [B], F2X [B1]: for forward-facing seats in Group 1 (9 to 18 kg);
- R3 [C]: rear-facing seats in Group 1 (9 to 18 kg);
- R2 [D], R1 [E]: rear-facing seats or shell seats in Group 0 or 0+ (less than 13 kg);
- L1 [F], L2 [G]: carrycots in Group 0 (less than 10 kg);
- **B2, B3** : boosters in groups 2 and 3 (15 to 25 kg and 22 to 36 kg).



Using a child safety system which is not approved for this vehicle will not properly protect the baby or child. They risk serious or even fatal injury.



Check that your child is always strapped in and that the belt or safety harness used is correctly set and adjusted
→ 68.
If necessary, adjust the seat position accordingly.

CHILD SEATS

9-seater Combi/Bus version: installation table

The table below summarises the information already shown on the previous diagram in order to ensure the regulations in force are respected.

9-seater Bus/Combi version								
Type of child seat	Weight of the child	Seat size ISOFIX [Height]	Front seat		Rear seat			
			Central passenger	Side passenger	2nd row side seats	2nd row centre seat	3rd row side seats	3rd row centre seat
Carrycot fitted across the vehicle Group 0	< 10 kg	L1 [F], L2 [G]	X	X	X	X	X	X
Rear-facing shell seat Groups 0 and 0+	< 13 kg	R1 [E]	X	X	IL (2)	X	X	X
Rear-facing seat Groups 0+ and 1	< to 13 kg and 9 to 18 kg	R3 [C], R2 [D]	X	X	X	X	X	X
Forward-facing seat Group 1	9 to 18 kg	F3 [A], F2 [B], F2X [B1]	X	X	IUF-IL (3)	X	X	X
Booster seat Groups 2 and 3	15 to 25 kg	B2	X	X	IUF-IL (3)	X	X	X
	22 to 36 kg	B3	X	X	IUF-IL (3)	X	X	X
I-Size seat	Rear-facing seat		X	X	X	X	X	X
	Forward-facing seat		X	X	X	X	X	X

CHILD SEATS

	Booster seat	X	X	X	X	X	X
--	--------------	---	---	---	---	---	---

X = Seat not suitable for fitting a child seat Isofix.

IUF/IL = Seat enabling a child seat with "Universal/Semi-universal or vehicle-specific" approval to be attached by Isofix (on equipped vehicles): check that it can be fitted.

(1) A carrycot can be installed across the vehicle and will take up at least two seats. Position the child with his or her feet nearest the door.

(2) In order to install a rear-facing child seat, move the front seat as far forward as possible, then move the front seat back as far as it will go, without allowing it to come into contact with the child seat.

(3) To fit a forward-facing child seat, position the back of the child seat in contact with the vehicle seatback. In all situations, remove the rear headrest of the seat on which the child seat is positioned. This action must be performed before fitting the child seat → 58. Do not push the seat in front of the child more than halfway back on its runners and do not recline the seatback more than 25°.

CHILD SAFETY: DEACTIVATING, ACTIVATING THE FRONT PASSENGER AIRBAG

Operation



DANGER

As the deployment of the front passenger Airbag is not compatible with the positioning of a rear-facing child seat, **NEVER fit a rear-facing child restraint system on a seat protected by an ACTIVATED front Airbag. This can cause the CHILD'S DEATH or SERIOUS INJURY.**



The passenger Airbag may only be activated or deactivated when the **vehicle is stationary with the ignition off.**

If it is interfered with when the vehicle is being driven, indicator

lights  and  will come on.

Switch the ignition off then on again to reset the Airbag in accordance with the lock position.



Using a child safety system which is not approved for this vehicle will not properly protect the baby or child. They risk serious or even fatal injury.

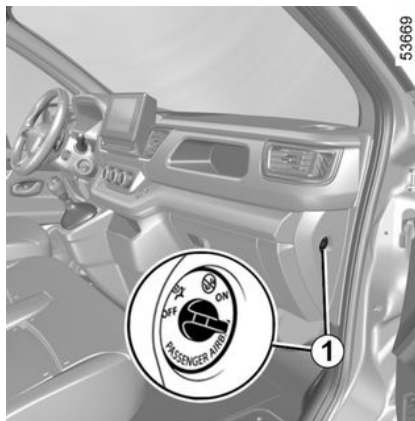

Deactivating the front passenger Airbag

Before installing a child seat on the front passenger seat:

- check that the child seat can be installed on this seat;
- it is essential **to deactivate** the Airbag for a rear-facing child seat.

To deactivate the Airbag: with the vehicle stationary and the ignition switched off, push and turn the lock **1** to the OFF position.

When the ignition is switched on, you

must check that the  warning light is illuminated on the display **2** and, depending on the vehicle, that the "Passenger airbag off" message is displayed.

This light remains continuously lit to let you know that you can fit a child seat.





CHILD SAFETY: DEACTIVATING, ACTIVATING THE FRONT PASSENGER AIRBAG

Activating the front passenger Airbag

You should reactivate the Airbag as soon as you remove the child seat from the front passenger seat to ensure the protection of the front passenger in the event of an impact.

To reactivate the Airbag: with the vehicle stationary and the ignition off, push and turn the lock **1** to the ON position.

When the ignition is switched on, you **must** check that the  warning

light is off and that the  warning light appears on the display **2** for around 60 seconds after each start-up. The front passenger Airbag is activated.

Instruction labels

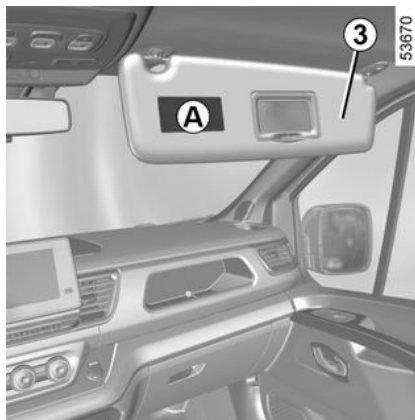

58035



senger sun visor **3** (see example of label above) are provided to remind you of these instructions.

Operating faults

It is forbidden to fit a rear-facing child seat to the front passenger seat if the Airbag activation/deactivation system is faulty.

Allowing any other passenger to sit in that seat is not recommended.

Contact your approved Dealer as soon as possible;



The passenger Airbag may only be activated or deactivated when the **vehicle is stationary with the ignition off**.

If it is interfered with when the vehicle is being driven, indicator

lights  and  will come on.

Switch the ignition off then on again to reset the Airbag in accordance with the lock position.

The markings on the dashboard and the labels **A** on each side of the pas-

DRIVING POSITION

Driving position: left-hand drive

2

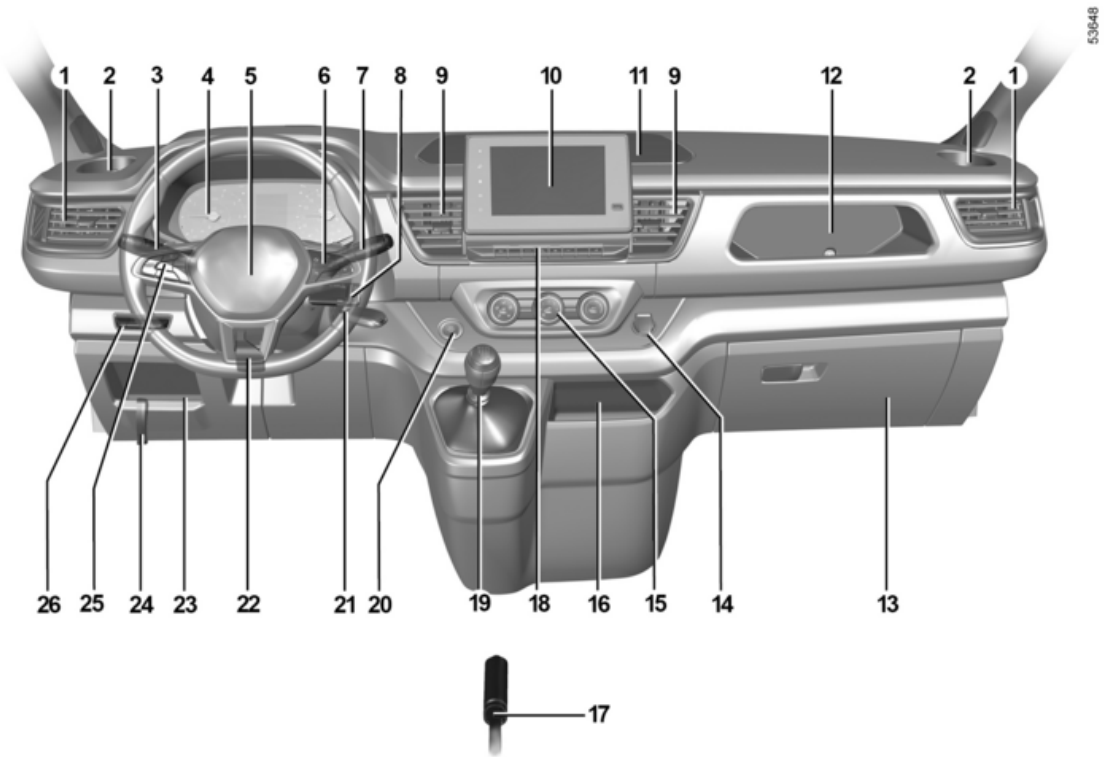

DRIVING POSITION

The fittings described below DEPEND ON THE VEHICLE VERSION AND COUNTRY.

1. Side air vents.

2. Location for ashtray or cup holder.

3. Stalk for:

- direction indicator lights;
- exterior lights;
- front fog lights;
- rear fog lights.

4. Instrument panel.

5. Driver Airbag and horn location.

6. Controls for:

- trip computer information read-out and vehicle settings customisation menu;
- remote radio and navigation system.

7. Stalk for:

- the windscreen and rear screen washers/wipers;
- trip computer and warning system information readout.

8. Multimedia controls.

9. Centre air vents.

10. Touch screen or radio or upper central storage compartment.

11. Storage compartment.

12. Passenger storage compartment location.

13. glove box or storage drawer.

14. Accessories socket or cigarette lighter.

15. Manual or automatic air conditioning controls.

16. Storage compartment or induction charging area.

17. Handbrake.

18. Controls for:

- hazard warning lights switch;
- ECO mode switch;
- opening elements central locking/unlocking;
- activating/deactivating the Stop and Start function;
- activation/deactivation of traction control,

19. Gearstick.

20. Engine start/stop button.

21. Ignition switch for vehicles with key.

22. Control for adjusting steering wheel reach.

23. Storage compartment.

24. Bonnet release control.

25. Cruise control/speed limiter main controls.

26. Controls for:

- activating/deactivating the "My Safety" function;
- electric headlight beam adjustment;
- instrument panel lighting dimmer.

DRIVING POSITION

Driver's position, right-hand drive

2

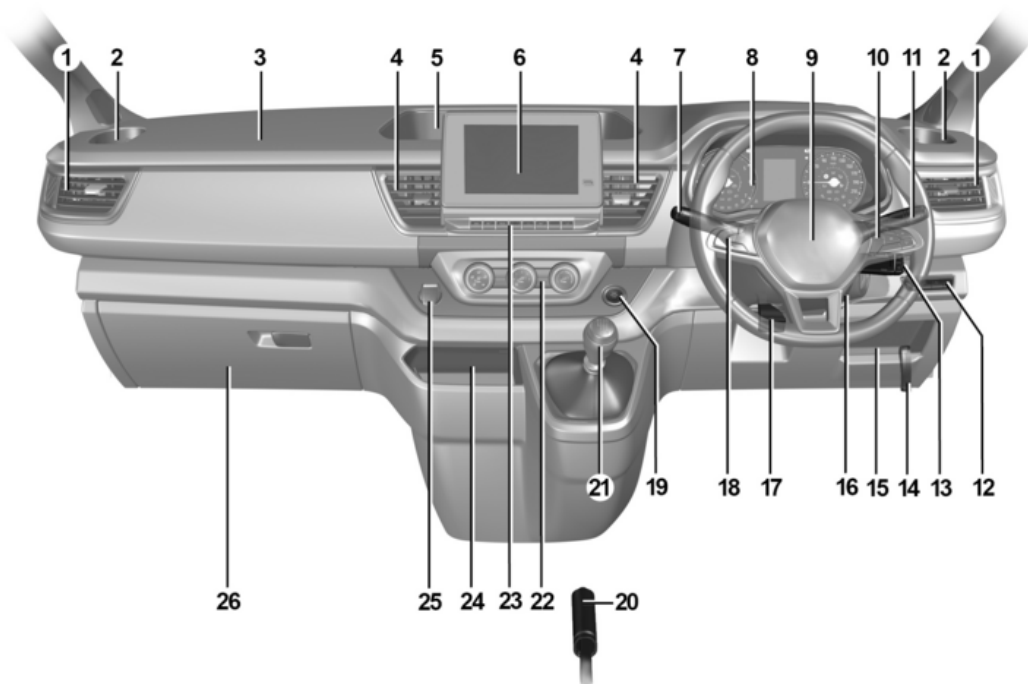

53725

DRIVING POSITION

The fittings described below DEPEND ON THE VEHICLE VERSION AND COUNTRY.

1. Side air vents.

2. Location for cup holders.

3. Passenger Airbag location.

4. Centre air vents.

5. Storage compartment.

6. Touch screen or radio or upper central storage compartment.

7. Stalk for:

- direction indicator lights;
- exterior lights;
- front fog lights;
- rear fog lights.

8. Instrument panel.

9. Driver Airbag and horn location.

10. Controls for:

- trip computer information read-out and vehicle settings customisation menu;
- remote radio and navigation system.

11. Stalk for:

- the windscreen and rear screen washers/wipers;
- trip computer and warning system information readout.

12. Controls for:

- activating/deactivating the "My Safety" function;
- electric headlight beam adjustment;
- instrument panel lighting dimmer.

13. Multimedia controls.

14. Bonnet release control.

15. Storage compartment.

16. Ignition switch for vehicles with key.

17. Control for adjusting steering wheel reach.

18. Cruise control/speed limiter main controls.

19. Engine start/stop button.

20. Handbrake.

21. Gearstick.

22. Manual or automatic air conditioning controls.

23. Controls for:

- hazard warning lights switch;
- ECO mode switch;
- opening elements central locking/unlocking;
- activating/deactivating the Stop and Start function;
- activation/deactivation of traction control,

24. Storage compartment or induction charging area.

25. Accessories socket or cigarette lighter.

26. Glovebox

TRIP COMPUTER

General information

2 Vehicle fitted with trip computer A

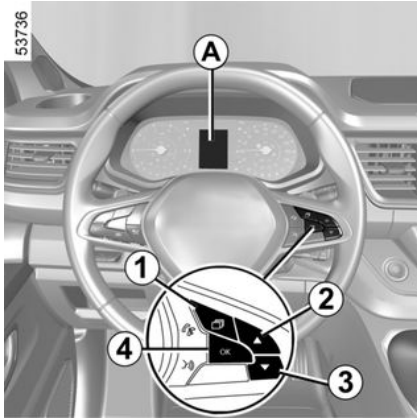

Depending on the vehicle, this includes the following functions:

- mileage;
- trip settings;
- information messages;
- operating fault messages (related to

the  warning light);

– warning messages (connected to the

 warning light).

Press switch **1** as many times as required to reach the "VEHICLE" tab.

Repeatedly press switch **2** or **3**.

Selections

(the display depends on the vehicle equipment and country)

a) Trip log, operating faults and information message readout;

b) journey settings:

- average energy consumption;
- current energy consumption.
- estimated range with remaining energy;
- distance travelled;
- average speed;

c) trip mileage recorder and average speed;

d) Reset the tyre pressure

e) set the time;

f) distance before service;

Resetting the trip mileage recorder and journey parameters (reset button)

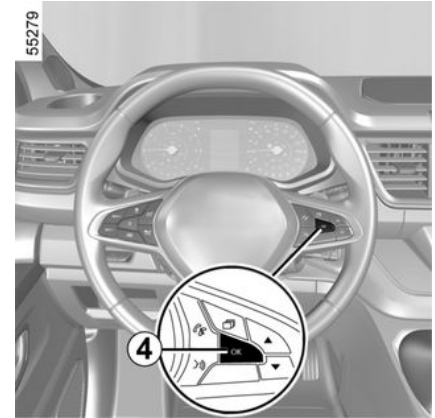

With one of the trip settings selected as the display, press and hold switch **4** "OK " until the display resets to zero.

Automatic resetting of the journey parameters

Resetting occurs automatically when the maximum value of any of the parameters is exceeded.

Interpreting some of the values displayed after resetting

The values showing average fuel consumption, range and average speed will become more stable and reliable

TRIP COMPUTER

the further you travel after pressing the reset button.

For the first few miles after pressing the reset key you will notice that the range increases as you travel. This range takes into account the average fuel consumption since the last time the reset button was pressed. However, average consumption can decrease when:

- the vehicle stops accelerating;
- the engine reaches its operating temperature (if the engine was cold when the reset key was pressed);
- when driving from an urban area on to the open road.

Vehicle fitted with trip computer B

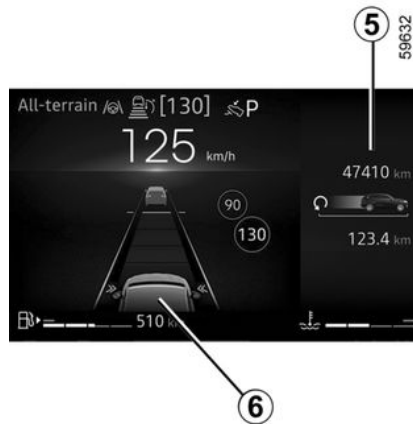
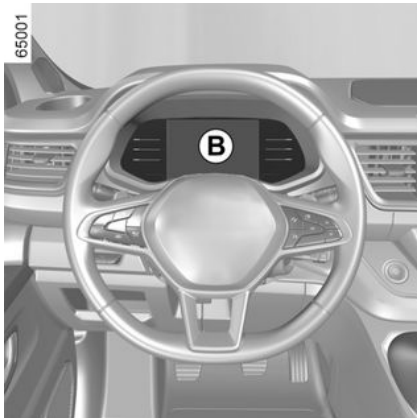

The functions are distributed in zones **5** and **6**.

Press switch **1** to navigate between zones and select the functions by pressing switches **2** or **3** (the display depends on the vehicle equipment and country):

- a)** Trip log, operating faults and information message readout;
- b)** journey settings:

- average energy consumption;
- current energy consumption.
- estimated range with remaining energy;
- distance travelled;
- average speed;

c) trip mileage recorder and average speed;

d) Reset the tyre pressure

e) set the time;

f) distance before service;

Resetting the trip mileage recorder and journey parameters (reset button)

(depending on the vehicle)

With one of the trip settings selected as the display, press and hold switch **4** "OK" until the display resets to zero.

Automatic resetting of the journey parameters

Resetting occurs automatically when the maximum value of any of the parameters is exceeded.

Interpreting some of the values displayed after resetting

The greater the distance travelled since the last reset, the greater the stability and reliability of the average energy consumption, range and speed values.

For the first few miles after pressing the reset key you will notice that the range increases as you travel.

TRIP COMPUTER

This range takes into account the average fuel consumption since the last time the reset button was pressed.

2

However, the average energy consumption may fall when:





- the vehicle stops accelerating;
- the engine reaches its operating temperature (if the engine was cold when the reset key was pressed);
- when driving from an urban area onto the open road.

TRIP COMPUTER

Journey settings



The display of information shown below **DEPENDS ON THE VEHICLE EQUIPMENT AND COUNTRY.**

2

Examples of selections	Interpreting the display selected
– 101 778 km – 112.4 km	a) Total mileage and trip mileage recorder.
Fuel  8 L	b) Trip settings: Fuel used. Fuel consumed since the last reset.
Average  5.8 L/100	c) Average fuel consumption since the last reset. The value is displayed after having travelled at least 400 metres since the last reset.
Current  7.4 L/100	d) Current fuel consumption. This value is displayed after a speed of approximately 19 mph (30 km/h) is reached.
Range  541 km	e) Estimated range with remaining fuel. The value is displayed after driving 400 metres.
Distance	f) Distance travelled since the last reset.

TRIP COMPUTER

2

Examples of selections	Interpreting the display selected
 522 km	
Average  89.4 km/h	g) Average speed since the last reset. The value is displayed after driving 400 metres.

Examples of selections		Interpreting the display selected
On-board computer with mileage-before-service message		
Service Intervals	Service in 24,855 miles (40,000 km) or 24 months	f) Mileage before service. With the ignition on, the engine not running and the display set to "Service Intervals", press button 2 or 3 for approximately five seconds to display the mileage before service (distance or time to the next service). When the distance or time value approaches its limit, there are several possible scenarios: – distance or time less than 932 miles (1,500 km) or one month : the "Service due in" message is displayed accompanied by the nearest limit (distance or time); – if the range is 0 miles (0 km) or if the service date is reached : the "Service Required" message is displayed accompanied by the  warning light. The vehicle requires a service as soon as possible.
	Service due in less than 186 miles (300 km) or 24 days	
	Service vehicle	

Depending on the vehicle, the mileage before an oil change varies according to the driving style (frequent driving at low speed, door-to-door journeys, extensive use at idling speed, towing a trailer, etc.). The distance remaining until the next oil change can therefore decrease more quickly in some cases than the actual distance travelled.

Reset: to reset the distance before the next service, press and hold the button **2** or **3** for approximately 10 seconds until the display shows the mileage before service permanently.

TRIP COMPUTER

Examples of selections	Interpreting the display selected
Tyre pressure init. long press	i) Reset the tyre pressure → 204.
Speed limiter 90 km/h	j) Cruise control - Speed limiter → 250 and → 254 programmed speed.
Cruise control 90 km/h	
16°	k) Clock and temperature → 150
12 : 00	
Vehicle Systems OK	l) Trip log Successive display: – information messages (passenger Airbag OFF, etc.); – operating fault messages (check the injection system, etc.).
ADBLUE 62%	m) Percentage volume of reagent remaining → 175 .
Use AdBlue before 1,491 miles (2,400 km)	n) Estimated range with remaining reagent → 175.

TRIP COMPUTER

Information messages

These can help in the vehicle starting phase, or give information about a selection or a driving status.

Examples of information messages are given in the following pages.

Examples of messages	Interpreting the display selected
« Parking Brake ON »	Indicates that the parking brake has been applied.
« Battery Low Start Engine »	Indicates that the vehicle must be started to recharge the battery (e.g. after the engine has been switched off for some time whilst listening to the radio).
« WARNING: Top Up Engine Oil »	Indicates that the oil level needs adjusting.
« Auto Door Lock OFF »	Indicates that the automatic door locking while driving is deactivated.
« WARNING: Check Power Steering »	Indicates that the steering column has not been locked.

TRIP COMPUTER

Operating fault messages

These appear with the  warning light and mean that you should drive very carefully to an approved dealer as soon as possible. If you fail to follow this recommendation, you risk damaging your vehicle.

They disappear when the display selection key is pressed or after several seconds and are stored in the computer log. The

 warning light stays on. Examples of operating fault messages are given in the following pages.

Examples of messages	Interpreting the display selected
« Clean Diesel Filter »	Indicates the presence of water in the diesel filter; contact an approved Dealer as soon as possible.
« Check vehicle »	Indicates a fault in one of the pedal sensors, battery management system or oil level sensor.
« WARNING: Check Airbag »	Indicates a fault in the restraint system in addition to the seat belts. In the event of an accident, it is possible that they may not be triggered.
« Check Anti- Pollution System »	– Indicates a fault in the vehicle's particle filter system. – Indicates a fault in the emissions reduction system when it is accompanied by the  → 175 warning light.

TRIP COMPUTER

Warning messages

2

These appear with the **STOP** warning light and require you to stop immediately, for your own safety, as soon as traffic conditions allow. Stop your engine and do not restart it. Call an approved Dealer.

Some examples of warning messages are given below. **Note:** the messages appear on the display either individually or alternately (when there are several messages to be displayed), and may be accompanied by a warning light and/or a beep.

Examples of messages	Interpreting the display selected
« WARNING: Engine Failure Risk »	Indicates an injection fault, the vehicle's engine has overheated or there is a serious engine fault.
« WARNING: Braking System »	Indicates a fault in the braking system.
« WARNING: Steering Fault »	Indicates a fault in the steering system.
" Electrical fault "	Indicates a fault in the vehicle battery charging circuit (alternator etc.).
« Puncture »	Indicates that at least one wheel is punctured or severely underinflated.

TRIP COMPUTER

Displays and indicators

Engine oil level low warning

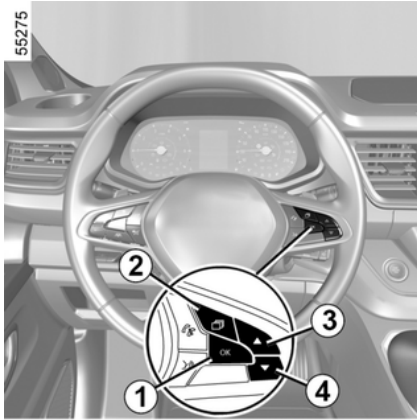

When the engine is started, the instrument panel display warns you when the minimum oil level is reached → 324.

The first time the warning appears, it can be cleared by pressing switch **1** "OK".

Subsequent warnings will disappear automatically after around 30 seconds.

Instrument panel A



It lights up when the ignition is switched on. In some cases, the appearance of a warning light is accompanied by a message.

Rev counter **5** (scale x 1,000)

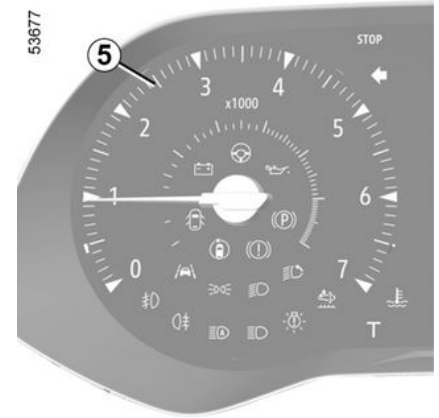

Automatic gearbox display **7** → 188



TRIP COMPUTER

Fuel gauge **8**

The number of squares lit shows the fuel level. When it is at minimum, the squares disappear and the low fuel level warning light comes on, depending on the vehicle.

Speedometer **9**

(km or miles per hour)



Control your speed only according to speedometer **6** or **9**.

In case of a difference between the speedometers, refer to the approved speedometer **9**, and consult an approved dealer.

Overspeed sound alert

The warning light  comes on and a beep sounds. This beep sounds when a speed limit is exceeded. For more information: ➔ **242**.

Instrument panel **B**

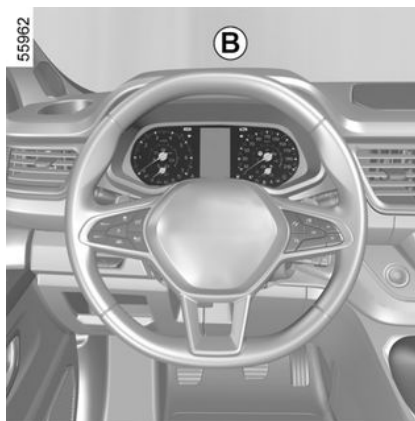

It lights up when the ignition is switched on. In some cases, the appearance of a warning light is accompanied by a message.

Depending on the vehicle, you can customise your instrument panel with colours of your choice. For vehicles fitted with a multimedia screen, refer to the multimedia instructions.

Vehicles not fitted with a multimedia screen

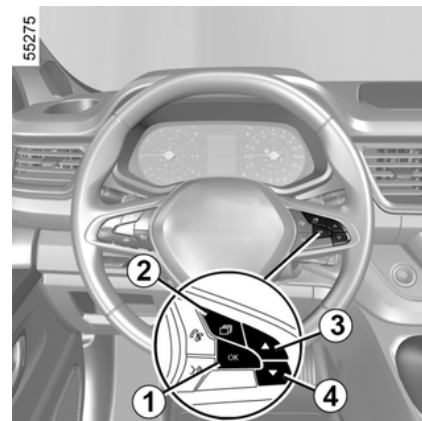

TRIP COMPUTER

- With the ignition off, press the switch **2** as many times as required to reach the vehicle tab **10**;
- press control **3** or **4** to reach the "Settings", then press switch **1** "OK ";
- repeat the same operation to reach "DASHBOARD", then "Units".

Rev counter **11**

(scale x 1,000)

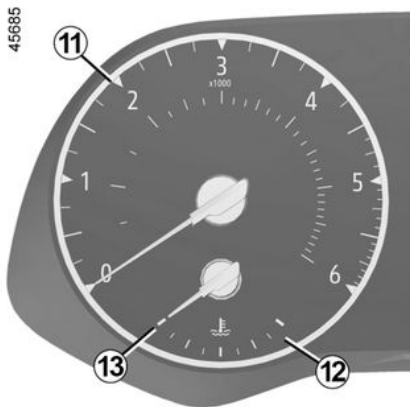

Coolant temperature indicator **12**

In normal use, the indicator **13** should be positioned before the red zone **12**. Under "intensive" operating conditions, the needle may approach this zone. This is not serious unless the warning

light **STOP** comes on accompanied by a message on the instrument panel and a beep.

Trip computer **14**

➔ 136

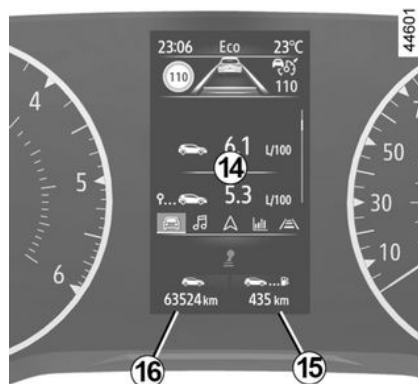

Estimated range with remaining fuel **15**

The value is displayed after driving 400 metres ➔ 139.

Total mileage recorder **16**

➔ 139

Driving style indicator **17**

➔ 199



Overspeed sound alert

The warning light  comes on and a beep sounds. This beep sounds when a speed limit is exceeded. For more information, ➔ 242.

Speedometer **18**

TRIP COMPUTER

Fuel gauge 19

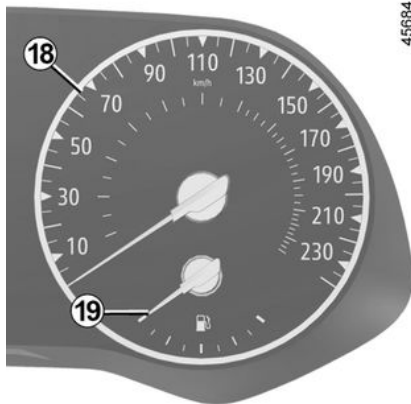

If the level is at the minimum, warning

light  integrated in the indicator comes on orange, accompanied by a beep. Fill up as soon as possible.

Instrument panel C



It lights up when the ignition is switched on.

In some cases, the appearance of a warning light is accompanied by a message.

Depending on the vehicle, you can customise your instrument panel with the content and colours of your choice.

For more information, refer to the equipment instructions.

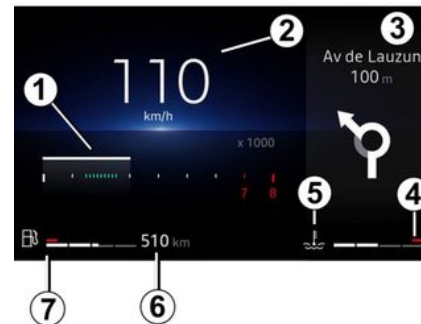

Rev counter 1 (scale x 1,000)

TRIP COMPUTER

This is displayed differently according to how the instrument panel is customised. Depending on the style selected, it may not be displayed.

Speedometer 2

Depending on the style selected, the display varies.

Overspeed sound alert

The warning light  comes on and a beep sounds. This beep sounds when a speed limit is exceeded. For more information: → 242.

Multimedia information 3

Depending on the vehicle, you can display information from the multimedia screen (the compass, telephone, navigation, etc.).

Please refer to the multimedia instructions for more information.

Coolant temperature indicator 5

In normal use, the indicator 5 should be located before zone 4.

Under "intensive" operating conditions, the needle may approach this zone.

This is not serious unless the warning light  comes on accompanied

by a message on the instrument panel and a beep.

Estimated range with remaining fuel 6

The value is displayed after driving 400 metres → 139.

Fuel gauge 7

If the level is at the minimum, the warning light integrated into the indicator appears in orange, accompanied by a beep.

Fill up as soon as possible.

Left-hand dial area

→ 136

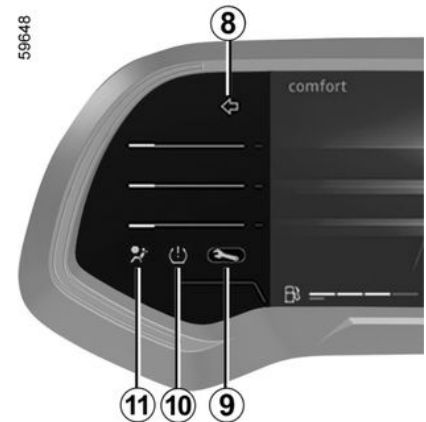

Direction indicators 8

Warning light 9 → 153

Tyre under-inflation warning light 10 → 204

Airbag warning light 11 → 71

Right-hand dial area

→ 136

TRIP COMPUTER

2

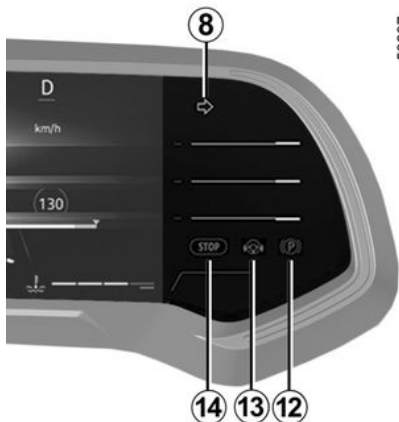

Parking brake warning light 12
→ 196

Hands-off steering wheel detection warning light 13 → 240

Urgent stop warning light 14 → 153

Clock and outdoor temperature



If the power supply is cut (battery disconnected, supply wire cut, etc.), the clock must be reset.

We recommend that you do not adjust these settings while driving.

Vehicles fitted with a multimedia screen.

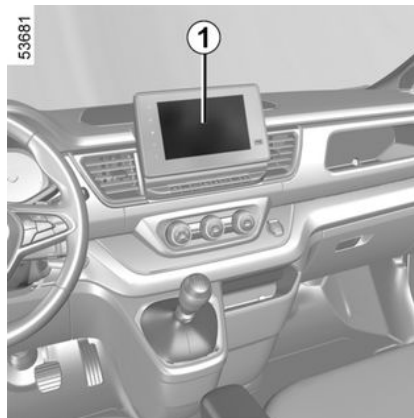

The time and outdoor temperature are displayed on the multimedia screen 1.

Refer to the multimedia instructions.

Vehicles not fitted with a multimedia display screen A

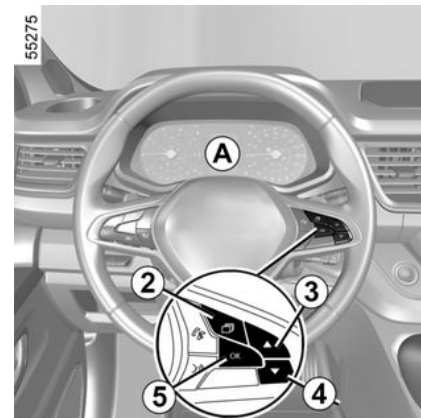

Press the switch 2 as many times as required to reach the "Vehicle" tab.

Repeatedly press control 3 or 4 to access the time setting function 6.

Press and hold switch 5 "OK" until the time flashes.

TRIP COMPUTER



Set the hour using control **3** or **4**, then press the switch **5** "OK" to confirm.

Set the minutes using control **3** or **4**, then press the switch **5** "OK" to confirm.

Vehicles not fitted with a multimedia display screen **B**

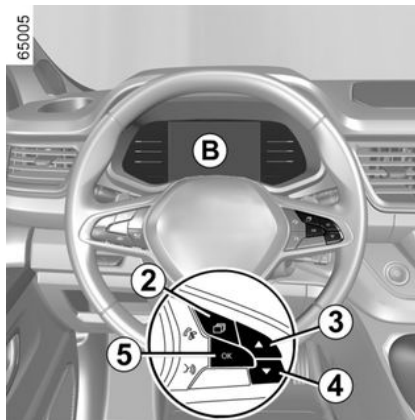

Press the switch **2** as many times as required to reach the "Settings" world.

Repeatedly press control **3** or **4** to reach the "Time setting" menu then press switch **5** "OK".

Press and hold switch **5** "OK" until the time flashes.

Set the hour using control **3** or **4**, press switch **5** "OK" to confirm, then set the minutes using control **3** or **4** and press switch **5** "OK" to confirm.

i Depending on the vehicle, If the electrical supply is cut (battery disconnected, broken supply wire, etc.), the clock will automatically go back to the right time after a few minutes once the system is capable of receiving information GPS.

Exterior temperature indicator

i Depending on the vehicle, If the electrical supply is cut (battery disconnected, broken supply wire, etc.), the clock will automatically go back to the right time after a few minutes once the system is capable of receiving information GPS.

TRIP COMPUTER

2



Exterior temperature indicator

As ice formation is related to climatic exposure, local air humidity and temperature, the external temperature alone is not sufficient to detect ice.

Special feature:

When the external temperature is between -3°C and $+3^{\circ}\text{C}$, the $^{\circ}\text{C}$ characters flash (indicates risk of ice).

WARNING LIGHTS

Introduction

The display of information shown below **DEPENDS ON THE VEHICLE EQUIPMENT AND COUNTRY.**



If no lights or sounds are apparent, this indicates a fault in the instrument panel. This indicates that it is essential to stop immediately (as soon as traffic conditions allow). Ensure that the vehicle is correctly immobilised and contact an approved Dealer.

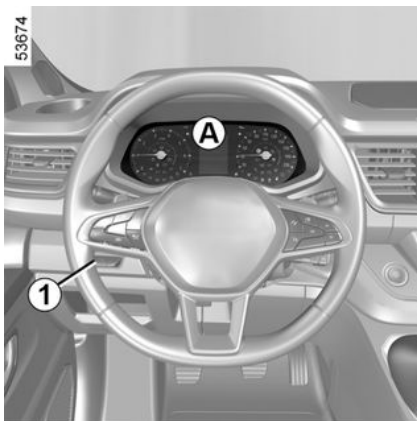

Instrument panel A: lights up when the ignition is switched on. Press or raise the switch **1** as many times as required to adjust the intensity.

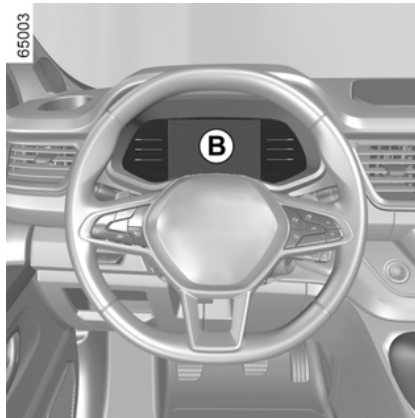

Instrument panel B: lights up when the ignition is switched on. Press or raise the switch **1** as many times as required to adjust the intensity.



Warning light



means you should drive **very carefully to an authorised dealer as soon as possible.** If you fail to follow this recommendation, you risk damaging your vehicle.

In some cases, the appearance of a warning light is accompanied by a message.



Side light tell-tale light



Main beam headlight tell-tale light



Dipped beam headlight tell-tale light



Front fog light tell-tale



Rear fog light tell-tale



Automatic main beam headlight warning light → 160



Left-hand direction indicator tell-tale light

WARNING LIGHTS

2

 **Right-hand direction indicator tell-tale light**

 **Tell-tale light for Airbag**

It lights up when the ignition or the engine is switched on and goes off after a few seconds.

If it does not light up when the ignition is switched on, or if it lights up when the engine is running, this indicates a fault in the system.

Contact your approved Dealer as soon as possible;

 **Low fuel level warning light**

This lights up when the ignition is switched on and goes out after a few seconds.

If it lights up when driving, fill up with fuel as soon as possible. There is only approximately 31 miles (50 km) worth of fuel left.

 **Urgent stop warning light**

This lights up when the ignition is switched on and goes out as soon as the engine is started. It comes on with other warning lights and/or messages, and is accompanied by a beep.

For your own safety, it requires you to stop immediately, as soon as traffic

conditions allow. Switch off the engine and do not restart it.

Call an approved dealer.

 **Handbrake on warning light and brake circuit fault warning light**

This comes on when the ignition is switched on and goes out as soon as the handbrake is released.

If it comes on during braking and is ac-

companied by the  warning light and a beep, it indicates that the fluid level in the circuit is low or that there is a braking system fault.

Stop as soon as traffic conditions allow and consult an approved dealer.



For your own safety, the

 warning light

requires you to stop immediately, as soon as traffic conditions allow. Switch off the engine and do not restart it. Call an approved dealer.



Battery charge warning light

This lights up when the ignition is switched on and goes out after a few seconds.

If it comes on on the road, accompa-

nied by the  warning light and a beep, this indicates an overload or discharge in the electrical circuit.

Stop as soon as traffic conditions allow and consult an approved dealer.



Oil pressure warning light

This lights up when the ignition is switched on and goes out after a few seconds.

If it comes on on the road, accompa-

nied by the  warning light and a beep, stop immediately and cut the ignition.

Check the oil level. If the level is normal, the warning light is related to something else. Call an approved dealer.



Warning light

This lights up when the ignition is switched on and goes out as soon as the engine is started. It can light up in conjunction with other warning lights and/or messages on the instrument panel.

WARNING LIGHTS

It means you should **drive very carefully** to an approved Dealer as soon as possible. If you fail to follow this recommendation, you risk damaging your vehicle.



Toxic fume filter system warning light

For vehicles equipped with this option, the light comes on when the ignition is switched on then goes out.

- If it lights up continuously, contact an approved dealer as soon as possible;
- If it flashes, reduce the engine speed until the light stops flashing. Contact an approved dealer as soon as possible → 199.



Anti-lock braking warning light

This lights up when the ignition is switched on and goes out after a few seconds.

If it comes on when you are driving, it indicates a fault on the antilock braking system.

Braking will then be as normal, without the ABS. Contact your approved Dealer straight away.



Electronic Stability Program (ESC) and traction control system warning light

This lights up when the ignition is switched on and goes out after a few seconds.

The → 211 warning light may appear for several reasons



Particle filter system warning light → 192



Warning light for reagent level and faults in the exhaust gas reduction system → 175



Coolant temperature warning light

It may light up in blue when the ignition is switched on or if the engine is started while the engine temperature is low. If it appears in red, stop and leave the engine idle for a minute or two.

The temperature should lower and the warning light should disappear. If not, stop the engine. Let the engine cool down, then check the coolant level → 327.

If the level is normal, the warning light is related to something else. Call an approved dealer.



Engine standby warning light → 184



Engine standby unavailable warning light → 184



Tyre under-inflation warning light

(depending on the vehicle)

This lights up when the ignition is switched on or when the engine starts, then disappears after a few seconds → 204.



Preheating warning light (Diesel version)

This should come on when the ignition is switched on. It indicates that the heater plugs are in operation. It goes out when preheating is complete. The engine can be started.



Traction control warning light → 212



Brake pedal warning light

This lights up when the brake pedal should be pressed → 188.



Speed limiter and cruise control indicator lights → 250 and → 254

WARNING LIGHTS



Adaptive cruise control warning light → 258



Gear change indicators

This lights up to advise you to change to a higher gear (arrow pointing upwards) or lower gear (arrow pointing downwards) → 199



Mode warning light ECO

This lights up when ECOmode is activated → 199

Perfo Performance mode indicator light

This lights up when performance mode is activated → 199



Freewheel mode indicator light

This lights up when freewheel mode is activated → 199.



Front seatbelt reminder warning light → 63

The warning light is displayed on the central display **A** when the ignition is switched on and if the driver's and/or front passenger and/or rear passenger seat belt(s) (if the seat is occupied) is not fastened.



Door status warning light

If it lights up when the ignition is switched on, it indicates that a door is not properly closed.

STEERING

Steering wheel



For safety reasons, only adjust the steering wheel when the vehicle is stationary.



Never switch off the ignition when travelling downhill, and avoid doing so in normal driving (power steering and brake servo will not function).

Adjusting the steering wheel height and depth

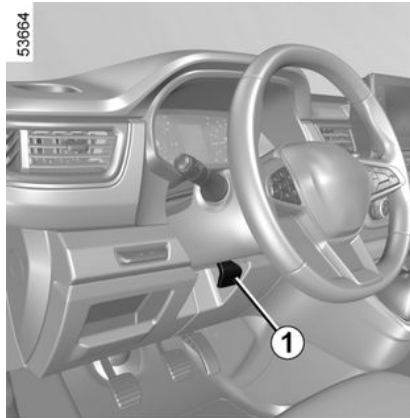

Pull the lever **1** and set the steering wheel to the required position, then push the lever beyond the point of resistance to lock the steering wheel in place.

Make sure that the steering wheel is correctly locked.



With the ignition switched off, or if there is a system fault, it is still possible to turn the steering wheel. The force required will be greater.

Power-assisted steering

Never drive with an inadequately charged battery.

Variable power assisted steering

The variable power-assisted steering system is equipped with an electronic control system which alters the level of assistance to suit the vehicle speed.

Steering is made easier during parking manoeuvres (for added comfort) while the force needed to steer increases progressively as the speed rises (for enhanced safety at high speeds).

REAR VIEW MIRRORS

2



For safety reasons, carry out any adjustments while the vehicle is stationary.



Objects observed in the rear view mirror glass are actually closer than they appear.

For your safety, take this into account in order to correctly assess the distance before any manoeuvre.

Electrically-adjustable rear view mirrors

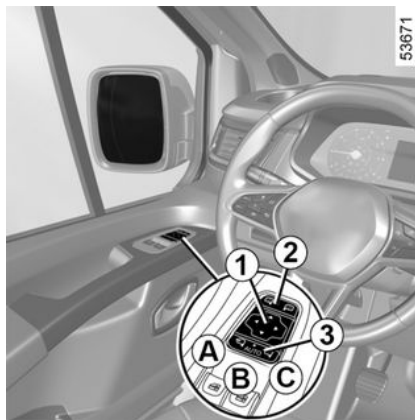

Adjustment

With the ignition on, select the door mirror using the switch **2**, then use the button **1** to adjust it to the desired position.

Folding rear view mirrors

The door mirrors automatically fold out when the vehicle is unlocked (switch **3** in position **B**). The door mirrors fold in when the vehicle is locked.

In any case, you can make the door mirrors fold in (switch **3** in position **C**) or fold out (switch **3** in position **A**).

Automatic mode is then deactivated. To reactivate it, position switch **3** to **B**.

Heated rear view mirrors

With the engine running, the door mirrors are heated in conjunction with the rear windows.

Interior rear view mirror

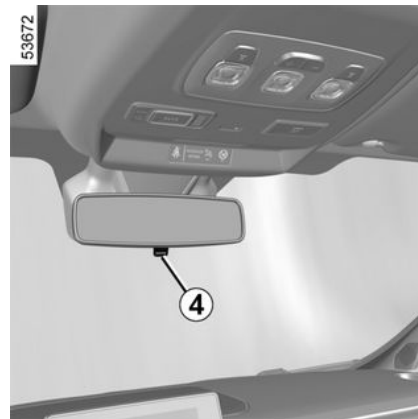

Its position can be adjusted.

Rear view mirror with lever **4**

When driving at night, to avoid being dazzled by the headlights of the vehicle behind, shift the small lever **4** located behind the rear view mirror.

REAR VIEW MIRRORS

Rear view mirror without lever 4

The rear view mirror automatically darkens when you are being followed by a vehicle using main beam headlights or in very bright lighting.

Wide angle rear view mirror 6

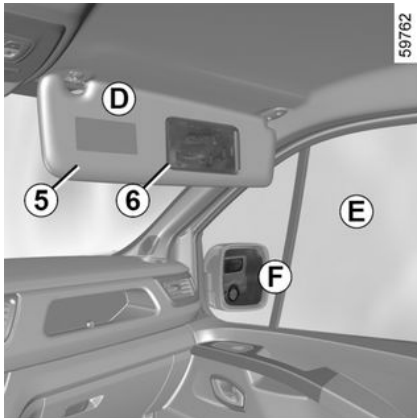

(depending on the vehicle)

Lower the sun visor **5** to access the wide angle rear view mirror in order to improve the side view when manoeuvring.

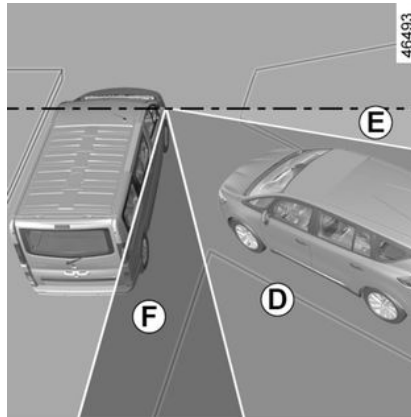

The various zones seen by the driver are:

- **D** in the wide-angle rear view mirror;
- **E** via the passenger window;
- **F** in the door mirror.

LIGHTING AND SIGNALS

Exterior lighting and signals

2

53683

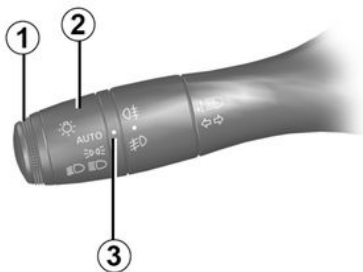

Side lights

 Turn the ring **2** until the symbol is opposite the mark **3**.

This indicator light on the instrument panel comes on.

Note: depending on the vehicle, the side lights can only be activated manually when the parking brake is applied or, depending on the vehicle, when the gear lever is in **P** position.

Otherwise, the "Unavailable position lights" message is displayed on the in-

strument panel to inform you that it is not possible to activate the side lights.

Daytime running lights function

The daytime running lights are activated automatically, without any action on the stalk **1**, when the engine is started and they are deactivated when the engine is switched off.



Dipped beam headlights



Before driving at night, check that the electrical equipment is operating correctly and adjust the headlight beams (if your vehicle is not carrying its normal load). As a general precaution, check that the lights are not obscured (by dirt, mud, snow or objects being transported).



Manual operation

Turn the ring **2** until the symbol is opposite the mark **3**. This indicator light on the instrument panel comes on.

Automatic operation

(depending on the vehicle)

LIGHTING AND SIGNALS

536883



Turn the ring **2** until the AUTO symbol is opposite the mark **3**: with the engine on, the dipped beam headlights switch on or off automatically according to the exterior light level, without any action on the stalk **1**.

Main beam headlights

 With the engine running and the dipped beam headlights lit, push stalk **1**. This indicator light on the instrument panel comes on.

To return to the dipped headlight position, pull the stalk **1** towards you again.

"Raise lights during driving" function

When the main beam headlights are activated, the "Raise lights during driving" function improves driver visibility by automatically raising the dipped beam headlight and the main beam headlights.

During deactivation of the main beam headlights, the dipped beam headlights return to their original position.

Automatic main beam headlights



Using a portable navigation system at night in the windscreen area below the camera may disturb the operation of the "automatic main beam headlights" system (risk of reflection on the windscreen).



If the vehicle is parked on the hard shoulder with the tailgate open, the rear lights may be obscured. You should make other road users aware of your vehicle by using a warning triangle or other equipment specified by the road traffic regulations of the country you are driving in.



The system may encounter difficulties under certain conditions, including:

- extreme weather conditions (rain, snow, fog, etc.);
- obstruction in front of the windscreen or camera;
- when a following or oncoming vehicle has weak or hidden lighting;
- incorrect settings for the front headlights;
- reflecting systems;
- ...

LIGHTING AND SIGNALS



Depending on the vehicle, this system switches the main beam headlights on and off automatically. It uses a camera located behind the interior rear view mirror to detect vehicles that are being followed and those coming in the opposite direction.

The main beam headlights come on automatically if:

- the exterior light level is low;
- no other vehicle or lighting is detected;
- the vehicle speed is above approximately 25 mph (40 km/h).

If any of the above conditions are not fulfilled, the system switches to dipped beam headlights.

Note: make sure the windscreen is not obscured (dirt, mud, snow, condensation, etc.).

To activate the automatic main beam headlights

Rotate the ring **2** until the AUTO symbol is aligned with the mark **3** and

push the stalk **1**. Warning light  comes on the instrument panel.

53663

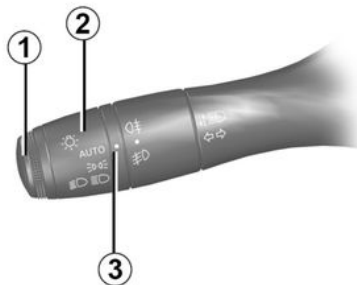

To deactivate the automatic main beam headlights

- Rotate the ring **2** to a position other than AUTO;
- or
- pull the stalk **1**.

Warning light  goes out on the instrument panel.

Note: the main beam headlights will be activated upon deactivation of the automatic main beam headlights function.

Operating faults

When the "Check Automatic Lighting" message appears on the instrument panel, the system is deactivated.

Consult an approved dealer.



The "automatic main beam headlights" system should under no circumstances be used to replace the driver's attention and responsibility with regard to vehicle lighting and adapting to light, visibility and traffic conditions.

LIGHTING AND SIGNALS

Switching off the lights

53683



The lights will go out automatically when the engine is switched off, the driver's door is opened or the vehicle is locked. In this case, the next time the engine is started the lights will be switched back on according to the position of the ring **2**.

Note: if the fog lights are lit, the lights are not switched off automatically.

Lights-on reminder audible alarm

If the lights are on after the engine is switched off, a warning beep sounds when the driver's door is opened to warn you that the lights are still on (to avoid draining the battery).

Operating faults

If the "WARNING: Check Lighting" message appears, accompanied by

the  warning light, and the

 warning light flashes on the instrument panel, this indicates that there is a lighting fault.

Consult an approved dealer.

Welcome and goodbye function

(depending on the vehicle)

Once the function is activated, the daytime running lights and the rear side lights will light up automatically upon detection of the card or when the vehicle is unlocked.

They switch off automatically:

- approximately one minute after lighting up;
 - when starting the engine, based on the position of the lighting stalk;
- or
- upon locking the vehicle.

Activating/deactivating the function

To activate or deactivate the external welcome function, please see the multimedia instructions.

Select "ON" or "OFF".

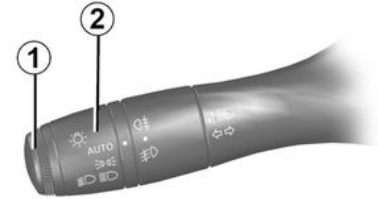

"See-me-home lighting" function

53683



This function enables you to briefly switch on the side lights and dipped beam headlights (e.g. to provide light when opening a gate).

With the engine stopped, the lights off and the ring **2** in AUTO position, pull the stalk **1** towards you: the side lights and dipped beam headlights will switch on for approximately 30 sec-

onds along with the  and  warning lights on the instrument panel.

To increase this duration, you may pull the stalk up to four times (total time restricted to approximately two minutes).

LIGHTING AND SIGNALS

The "Lighting on ___" message followed by the remaining time will appear as confirmation. You can then lock your vehicle.

To switch off the lights before they switch off automatically, turn the ring **2** to any position, then return it to position AUTO.

53683

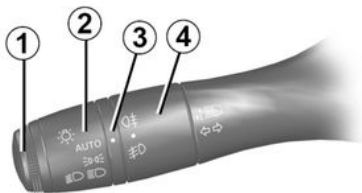

Front fog lights

i When driving in fog or snow, or when transporting objects which are higher than the roof, the headlights do not come on automatically. The fog lights are controlled by the driver: indicator lights on the instrument panel inform you whether they are on (indicator light on) or off (indicator light off).

⚡ Turn centre ring **4** on the stalk **1** until the symbol faces mark **3**, then release it.

Operation of the fog lights depends on the exterior lighting selected, and an indicator light will light up on the instrument panel.

Rear fog lights

⚡ Turn centre ring **4** on the stalk until the symbol faces mark **3**, then release it.

Operation of the fog lights depends on the exterior lighting selected, and an indicator light will light up on the instrument panel.

Do not forget to switch off the fog lights when they are no longer needed, to avoid inconveniencing other road users.

Switching off the lights

Rotate the central ring **4** again to align the mark **3** with the symbol of the fog lights that you wish to switch off. The corresponding indicator light on the instrument panel goes out.

The front and rear fog lights switch off when the exterior lights are switched off.

Cornering lights

(depending on the vehicle)

Driving in forward gear at a speed below approximately 25 mph (40 km/h), with the dipped beam headlights on and subject to certain conditions (the angle of the steering wheel, the indicator lights on, etc.), when taking a corner one of the front fog lights will switch on to light the inside of the bend.

When reverse gear is engaged and the dipped beam headlights are on, the two front fog lights illuminate automatically.

Note: when shifting from reverse gear into forward gear (e.g. during a parking manoeuvre), the two front fog lights re-

LIGHTING AND SIGNALS

main lit until the vehicle speed exceeds approximately 6 mph (10 km/h).

Headlight beam adjustment

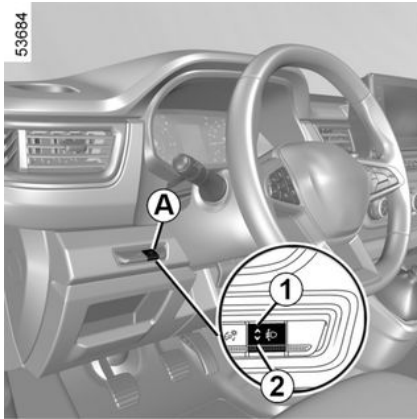

On vehicles fitted with this function, control **A** allows you to adjust the height of the beams according to the load.

With the dipped beam headlights on, press the top **1** of control **A** to raise the headlight beams or press the bottom **2** to lower them.

Load status	Control position
Driver only or with passenger	0

Load status	Control position
All seats occupied	1
Driver with passengers and luggage (or load) reaching the maximum permissible all-up weight	2
Driver without a passenger and with luggage (or load) reaching the maximum authorised load weight	3 or 4
The table below gives some examples. In all cases, adjust the control A according to the vehicle load so that the road can be seen and other drivers are not dazzled.	

AUDIBLE AND VISUAL SIGNALS

Horn

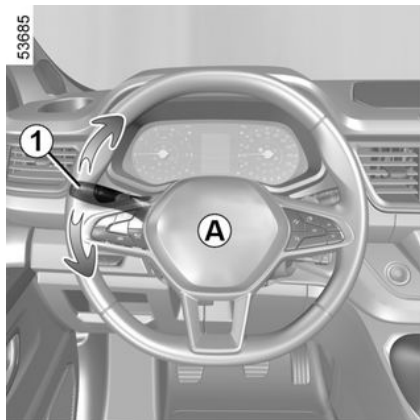

Press the steering wheel boss **A**.

Headlight flasher

To flash the headlights pull the stalk **1** towards you.

Direction indicators

Move stalk **1** parallel to the steering wheel and in the direction you are going to turn it.

One-touch mode

Briefly shift the stalk **1** upwards or downwards, not exceeding the point of resistance, then release it: the stalk

will return to its original position and the direction indicator light concerned will flash three times.

Hazard warning lights

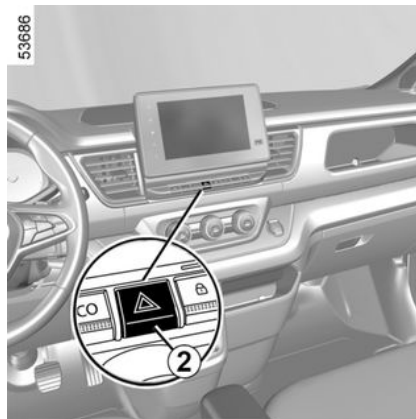

 Press the switch **2**.

This switch activates all four direction indicators and the side indicator lights simultaneously. It must only be used in an emergency to warn drivers of other vehicles that you have had to stop in an area where stopping is prohibited or unexpected, or that you are obliged to drive under special conditions.

Windscreen wiper, washer

Efficiency of a wiper blade

Check the condition of the wiper blades. How long they last depends on you:

- it must remain clean: clean the blade and the screen regularly with soapy water;
- do not use it when the screen is dry;
- free it from the screen when it has not been used for a long time.

In all cases, replace it as soon as it begins to lose efficiency: approximately once a year → 360.

Precautions for using the wipers

In the event of obstacles on the windscreen (dirt, snow, ice etc.), clean the windscreen (including the central area located behind the interior rear view mirror) before starting the wipers (risk of motor overheating).

If an object is preventing a blade from moving, it may stop functioning. Remove the obstacle and reactivate the wiper using the wiper stalk.



Before taking any action on the windscreen (washing the vehicle, de-icing, cleaning the windscreen, etc.) return the stalk **1** to position **B** (off).

Risk of injury and/or damage.



When working in the engine compartment, ensure that the windscreen wiper stalk is in position

B (stop).

Risk of injury.

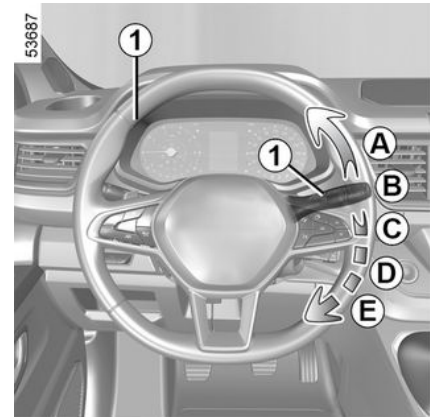

With the ignition on, move the stalk **1**.

A a single sweep of the wipers.

A short push will trigger one sweep of the wipers.

B switching off.

C intermittent wiping.

The wipers will pause for several seconds between sweeps. It is possible to change the interval between sweeps by rotating the ring **2**.

- **D** slow continuous wiping.
- **E** fast continuous wiping.

WIPER

i Positions **C** and **D** are accessible with the ignition on. Position **E** is accessible only when the engine is running.

Special feature

When driving, the wiping speed slows down whenever the vehicle stops. For example, fast wiping speed will slow to normal wiping speed.

As soon as the vehicle moves off, wiping will return to the speed originally selected. Any action on the stalk **1** overrides and cancels the automatic function.

Vehicles with automatic wiper function

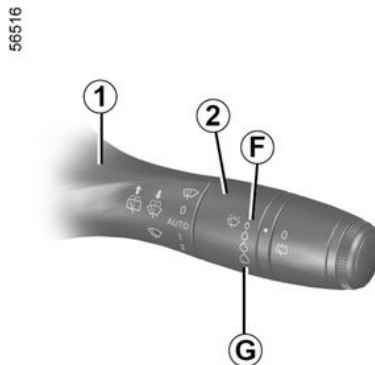
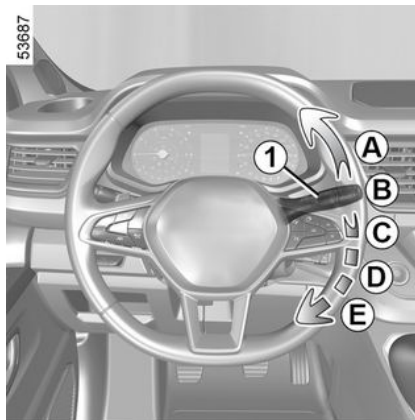

With the engine running, move the stalk **1**.

A a single sweep of the wipers.

A short push will trigger one sweep of the wipers.

B switching off.

C automatic wiper function

When this position is selected, the system detects water on the windscreen and triggers the wipers at a suitable wiping speed. It is possible to change the triggering threshold and the interval between sweeps by turning the ring **2**:

- **F**: minimum sensitivity;
- **G**: maximum sensitivity.

i Position **D** is accessible with the ignition on. Positions **C** and **E** are accessible only with the engine running.

The higher the sensitivity, the quicker the wipers will react and the faster the wipe.

Note:

- the rain sensor is only intended as a driving aid. In the event of reduced visibility, the driver should manually activate the wipers. In foggy weather or

WIPER

during snowfalls, wiping is not automatically triggered and remains under the driver's control;

- in the event of temperatures below zero, automatic wiping is not activated when the vehicle is started. It is automatically activated as soon as the vehicle exceeds a certain speed (approximately 5 mph (8 km/h));
- do not activate automatic wiping in dry weather;
- fully de-ice the windscreen before activating automatic wiping;
- when washing using a roller type car wash, return the stalk **1** to the off position **B** to deactivate automatic wiping.
- **D slow continuous wiping.**
- **E fast continuous wiping.**

Note: there is a maintenance position for replacing the wiper blades.

This position enables the blades to be lifted to remove them from the windscreen.

It may be useful to:

- clean the blades;
- release the blades from the windscreen in winter;
- replace the blades.

With the ignition on and the engine stopped, fully lower (position **E**) the windscreen wiper stalk **1**. The wiper arms stop in a position away from the bonnet → **360**.

Operating faults

In the event of a malfunction of the automatic wiping, the wiper is set to intermittent wiping. Call an approved dealer.

The rain sensor operation may be interrupted in the event of:

- damaged windscreen wipers: a film of water or traces left by a blade in the sensor's detection zone may increase the response time of the automatic wiper, or increase the wiping frequency;
- a windscreen with any chip or crack near the sensor, or a windscreen covered in dust, dirt, insects, ice, the use of washing wax and water-repellent chemicals. The windscreen wiper will be less sensitive or may even not react at all.

Windscreen washer

With the ignition on, pull the stalk **1** towards you.

A brief pull will trigger a single sweep of the wipers, in addition to the windscreen washer.

A longer press will trigger three sweeps of the wipers followed a few seconds later by a fourth, in addition to the windscreen washer.

Rear screen wiper, washer

Rear windscreen wiper



Do not use the wiper arm to open or close the tailgate.

Efficiency of a wiper blade

Check the condition of the wiper blades. How long they last depends on you:

- it must remain clean: clean the blade and the screen regularly with soapy water;
- do not use it when the screen is dry;
- free it from the screen when it has not been used for a long time.

In all cases, replace it as soon as it begins to lose efficiency: approximately once a year → **360**.

Precautions for using the wipers

- In freezing or snowy weather, clear the screen before starting the wipers (risk of motor overheating);
- ensure that no objects are obstructing the travel of the blade.



When working in the engine compartment, ensure that the windscreen wiper stalk is in the park position.

Risk of injury.



Before carrying out action on the windscreen (washing the vehicle, de-icing, cleaning the windscreen, etc.) return the stalk **1** to the off position.

Risk of injury and/or damage.

56516



With the ignition on, rotate the ring **3** on the stalk **1** until the symbol is aligned with the mark **2**.

To stop the operation, rotate the ring **3** again to the off position.

Note: when washing using a roller type car wash, return the ring **3** on the stalk **1** to the stop position to deactivate automatic wiping.

Follow usage recommendations.

Activation/Deactivation of the rear screen wiper

Engaging reverse gear triggers intermittent wiping (if the front wipers are in operation). If your vehicle is equipped with a vehicle settings customisation

WIPER

menu, you can opt to activate or deactivate this function. Refer to the multimedia instructions.

For vehicles not fitted with a settings customisation menu, you can have this function deactivated by an authorised dealer.

In the event of obstacles present on the rear window (dirt, snow, etc.), the wiper will try to sweep away all the obstacles.

If an obstacle prevents the blade from moving, it can be stopped. Remove the obstacle, wait for around 30 seconds and reactivate the wiper using the wiper stalk.

Precautions

- If the weather is icy, check that the blade is not stuck to the windscreen before operating the wipers. If you activate the wiper while the blade is blocked by ice, you risk damaging both the blade and the wiping motor.
- Do not operate the wipers on a dry screen. This will lead to the premature wear or damage to the blades.

Rear screen washer, wiper

56516



With the ignition on, push and hold the stalk **1** then release it.

Holding for longer will trigger three sweeps of the wipers followed, a few seconds later, by a fourth, in addition to the windscreen washer.

FUEL TANK

Introduction

2



To fill up with fuel, the engine must be off (and not only on standby in the case of vehicles equipped with the Stop and Start function): you must switch off the ignition → 180, → 184.
Fire hazard.



Do not mix even small amounts of petrol (unleaded or E85) with diesel.
Do not use ethanol-based fuel if your vehicle is not compatible with this fuel.
Do **not** add reagent to the fuel – otherwise you risk damaging the engine → 175.
If you wish to add an additive to the fuel, use a product approved by our Technical Department. Consult an approved dealer.



Persistent smell of fuel

If you notice a persistent fuel odour you should:

- stop the vehicle when traffic conditions allow it and switch off the ignition;
- switch on the hazard warning lights and ask your passengers to leave the vehicle and stay clear of the traffic;
- contact an authorised dealer.



No modifications whatsoever are permitted on any part of the fuel supply system (electronic units, wiring, fuel circuit, injectors, protective covers, etc.) as this may be dangerous (unless undertaken by qualified Network personnel).



Please note when working close to the engine that it may be hot. The engine cooling fan may also start at any moment. The



label in the engine compartment reminds you of this.
Risk of injury.



Fuel filler cap: this is a specific type.

If you have to replace it, make sure it is identical to the original cap. Contact an approved Dealer.
Never place the cap near a source of heat or flame.
Do not wash the filler area with a high pressure washer.

FUEL TANK

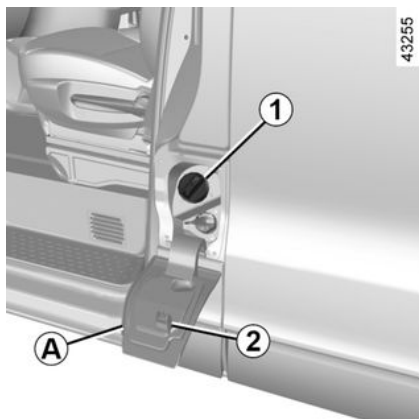

Useful capacity of fuel tank: approximately 17.60 gal (80 litres).

Open the front left-hand door to open the flap **A**.

Use the cap holder **2** on the flap **A** during filling to hold the cap **1** in place.

Fuel grade

Use a high-grade fuel that complies with the legislation in force in each country. It must comply with the specifications shown on the label located on the flap **A** ➔ **377**.

Filling with fuel

With the ignition off, insert the nozzle and insert it **fully** before turning it on to fill the fuel tank (risk of splashing).

Keep the nozzle in this position throughout the entire filling operation.

When the pump cuts out automatically at the end of the filling procedure, a maximum of two further filling attempts may be made, as there must be sufficient space in the fuel tank to allow for expansion.

Make sure that no water enters the fuel tank during filling.

After filling, refit the cap **1** and close the flap **A** to prevent any water or foreign bodies from entering the system.

Always make sure that the cap **1**, the flap **A** and its perimeter remain clean and free of dust, mud, dirt, etc.



Fuels that comply with the European standards with which vehicle engines marketed in Europe are compatible ➔ **377**.

Special case

When the vehicle has been stationary for around three months, **you must**

add fuel to prevent damage to the fuel pump.

To do this, with the ignition off, fill up with fuel or add at least approximately 2.20 gallons (**10 litres**) then start the engine to operate the pump and renew the fuel in the circuit.

If it is not possible to add at least 2.20 gallons (10 litres) of fuel due to the fuel level in the tank, drive the vehicle until the tank has capacity.

Running out of fuel on diesel versions

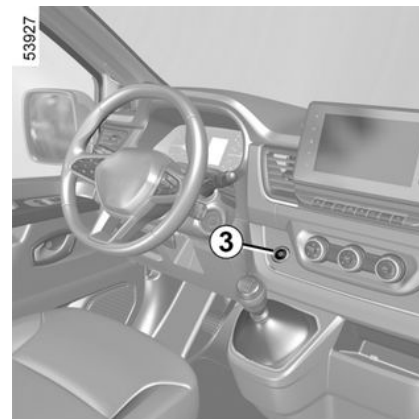

Vehicles with key/remote control

– Turn the ignition key to the "On" position **M** ➔ **179** and wait for a few min-

2

FUEL TANK

utes before starting to allow the fuel circuit to be primed;

- turn the key to D position. If the engine does not start, repeat the procedure;
- if the engine does not start after several attempts, please contact an authorised dealer.

Vehicles with card

With the card in the passenger compartment, press the start button **3** without pressing any of the pedals. Wait a few minutes before starting. This will enable the fuel circuit to be primed. If the engine does not start, repeat the procedure.

2

REAGENT TANK

Introduction



The reagent must not come into contact with eyes or skin. If it does, wash the affected area with plenty of cold water. If necessary, consult a doctor.



No work whatsoever is permitted on any part of the system. To prevent damage, only qualified personnel from our network may work on the system.



If the "XXX MILES (KM) lockout fill AdBlue" message appears, fill the reagent tank and refer to the filling instructions.

Risk of immobilisation of the vehicle.



Fuel filler cap: this is a specific type.

If you have to replace it, make sure it is identical to the original cap. Contact an approved Dealer. Do not wash the filler area with a high pressure washer.

Please ensure that you comply with the legislation of your country.

It is important to remember that failure to respect regulations in force could lead to legal action being taken against the vehicle owner.

Operating principle

The reagent is intended for Diesel engines fitted with the SCR (selective catalytic reduction) system. Using the reagent reduces the quantity of nitrogen oxides in exhaust gases.

Consumption in real time depends on vehicle usage conditions, the equipment fitted and the user's driving style.

Reagent quality

Use **only reagents which comply with the ISO 22241** standard and in accordance with the mark on the tank filler cap.

Topping up

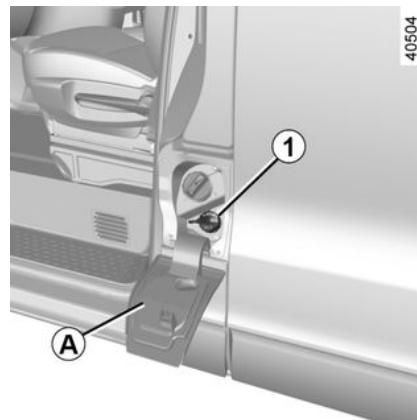

Useable capacity of the tank: between approximately 4.84 gal and 5.5 gal (22 litres and 25 litres) (depending on the vehicle).

With the ignition off, open the front left-hand door to open the flap **A**. Loosen the cap **1**.

Note: ammonium hydroxide vapour may escape from the cap opening when the tank temperature is high.

REAGENT TANK

 To fill up with reagent, the engine must be stopped (not just on standby in the case of vehicles with the Stop and Start function). You must switch off the ignition → 180, → 184.

Precautions for use

The tank can be filled at the pump. In other cases, it is essential to read the information shown on the reagent container (e.g. the can or bottle).

When filling, **handle the reagent with care as it can damage clothes, shoes, the bodywork, etc.**

If the reagent overflows, or contaminates any paintwork, clean the affected area quickly with plenty of cold water and a soft cloth.

Note: if the reagent fluid crystallises, use a soft sponge.

In extreme cold weather conditions In frosty weather conditions, the reagent tank should be refilled as

soon as the  warning light and the "TOP UP AdBlue before 1200 km" message appear on the instrument panel.

Special cases



The reagent fluid freezes below approximately -10°C .

If it is necessary to top up or fill the reagent ( on):

- park the vehicle in a warmer area (temperature above approximately -10°C);
- do not attempt to fill while the fluid is frozen;
- wait for the reagent to return to its liquid state (approximately eight hours);
- top up or fill with reagent.

Note: if it is not possible to apply the procedure, have an accredited professional top up or refill the reagent fluid.

When the vehicle is travelling in temperatures below approximately

-20°C , the  and  warning lights appear on the instrument panel accompanied by the "Check injection" message. This is not necessarily a fault but related to the freezing of the fluid. Under these conditions, follow the instructions mentioned above. Do not top up the fluid and restart the vehicle after the reagent has returned to its liquid state.

If the warning lights and message continue to appear, there is another

cause. Contact your approved Dealer as soon as possible.



 After filling the reagent tank, check that the cap and cover are closed, start the engine and **WAIT 10 seconds with the vehicle stationary, engine on**, before setting off again. If this operation is not carried out, the filling of the tank will not be taken into account automatically until after several dozens of minutes of driving. The "Fill AdBlue" message and/or the warning lights will continue to appear until the filling has been registered by the system.

REAGENT TANK

Maintenance/Range

The information displayed on the instrument panel may be accompanied by a beep.







2

Indicator lights	Messages	What to do?
-	« Top Up AdBlue before 2400 km »	When the message is displayed when the ignition is switched on, you have less than 1,488 miles (2,400 km) range . Refill, or have an Approved Dealer refill the reagent in the tank.
 appears.	« TOP UP AdBlue before 1200 km »	When the message is displayed when the ignition is switched on, you have between 744 miles (1,200 km) and 496 miles (800 km) range . Refill, or have an Approved Dealer refill the reagent in the tank.
 appears.	"XXX MILES (XXX KM) lockout fill AdBlue"	The message is displayed when the ignition is switched on and is repeated: - approximately every 62 miles (100 km), you have a range of between about 496 miles (800 km) and 124 miles (200 km) ; - approximately every 31 miles (50 km), you have less than 124 miles (200 km) range . In any event, fill or have an Approved Dealer fill the reagent tank as soon as possible .
 flashes or comes on, depending on the vehicle.	"0 MILES (0 KM) lockout fill AdBlue"	The engine will not start. To restart, you must fill the reagent tank yourself.

REAGENT TANK

System faults

When the indicator lights light up, this may be accompanied by a beep.

Indicator lights	Messages	What to do?
 and  illuminate.	<p>« Check Anti- Pollution System »</p> <p>« AdBlue quality to check »</p> <p>« AdBlue injection to check »</p>	<p>Indicates a fault in the system. Contact your approved Dealer as soon as possible.</p>
 and  illuminate.	<p>"XXX MILES (XXX KM) lockout emission control"</p>	<p>Indicates a system fault and that less than 621 miles (1,000 km) remains, or, depending on the vehicle, less than 497 miles (800 km) remains until it is no longer possible to restart the vehicle.</p> <p>These warnings are repeated:</p> <ul style="list-style-type: none"> – every 62 miles (100 km) until between approximately 621 miles (1,000 km) and 124 miles (200 km) remains or, depending on the vehicle, between 497 miles (800 km) and 124 miles (200 km) remains until it is no longer possible to restart the vehicle; – Every 31 miles (50 km) when there is less than 124 miles (200 km) left before the vehicle cannot be restarted. <p>Contact your approved Dealer as soon as possible.</p>
 and  illuminate.	<p>"0 MILES (0 KM) lockout emission control"</p>	<p>Indicates that after the ignition is switched off the vehicle will not restart. Call an approved dealer.</p>

RUNNING IN

Vehicle with key

Diesel version

For the first **932 miles (1,500 km)**, do not exceed 80 mph (130 km/h) in the highest gear, or 2,500 rpm. After completing this mileage you may drive faster, although you may only expect top performance after approximately 3,600 miles (6,000 km).

During the running in period, do not accelerate hard while the engine is still cold and do not let the engine over-rev.

Service intervals: refer to your vehicle's maintenance document.

Note: for a new vehicle in the running-in phase: the coolant level may be higher than the "MAXI" mark on the tank, then drop to between the "MINI" and "MAXI" marks. This does not present a risk.



"Stop and apply steering lock" position (LOCK 0)

To lock: remove the key and turn the steering wheel until the steering column locks.

To unlock: turn the key and the steering wheel slightly.

"On" position (ON 2)

The ignition is switched on: Any accessories (radio etc.) can be used.

"Start" position (START 3)

If the engine fails to start at the first attempt, the key must be turned back before the starter can be activated

again. Release the key as soon as the engine starts.

Note: on diesel versions, it make take several seconds between turning the key and the engine starting to allow for engine preheating.

STARTING, STOPPING THE ENGINE

Ignition-starter switch on a vehicle with key

3



Never start your vehicle while freewheeling on a gradient. Risk of non-activation of power-assisted steering.

There is a risk of accidents.



Never switch off the ignition before the vehicle has stopped completely. Once the engine has stopped, the brake servo, power-assisted steering, etc., and the passive safety devices such as the Airbags and pretensioners will no longer operate.



Driver's responsibility when parking or stopping the vehicle

Never leave an animal, child or adult who is not self-sufficient alone in your vehicle, even for a short time.

They may pose a risk to themselves or to others by starting the engine, activating equipment such as the electric windows or locking the doors.

Also, in hot and/or sunny weather, please remember that the temperature inside the passenger compartment increases very quickly.

RISK OF DEATH OR SERIOUS INJURY.

Starting the engine



Turn the ignition key to the "ON" position 2 and hold this position until the

engine preheating light goes out



Starting the vehicle

On flat, level ground, with the vehicle unladen, you are recommended to start in second gear.

STARTING, STOPPING THE ENGINE

To start:

on vehicles equipped with automatic gearboxes, set the lever to P or N position.

For all vehicles:

turn the key to the "START" position 3 **without pressing the accelerator pedal.**

Release the key as soon as the engine starts.

Stopping the engine

With the engine idling, return the key to "LOCK" position 0.

Ignition-starter switch on a vehicle with card



Starting the vehicle

On flat, level ground, with the vehicle unladen, you are recommended to start in second gear.



Never start your vehicle while freewheeling on a gradient. Risk of non-activation of power-assisted steering.

There is a risk of accidents.



When you leave your vehicle, especially if you have your card with you, check that the engine is completely switched off.



Driver's responsibility when parking or stopping the vehicle

Never leave an animal, child or adult who is not self-sufficient alone in your vehicle, even for a short time.

They may pose a risk to themselves or to others by starting the engine, activating equipment such as the electric windows or locking the doors.

Also, in hot and/or sunny weather, please remember that the temperature inside the passenger compartment increases very quickly.

RISK OF DEATH OR SERIOUS INJURY.

STARTING, STOPPING THE ENGINE

53723



55547



53927

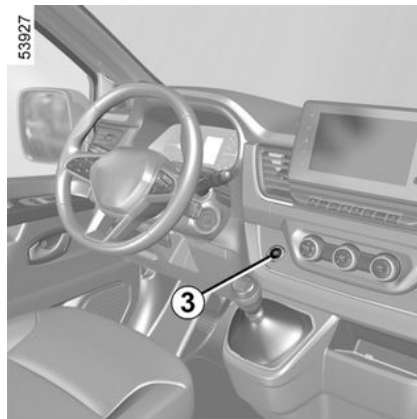

3

The card must be in detection zone **1** for the van version or in detection zone **2** for the combi version.

Press button **3**.

To start:

- on a vehicle with an automatic gearbox, set the lever to P or N position, press the brake pedal and then press the button **3**;
- on vehicles with a manual gearbox, press the brake pedal or clutch and press button **3**. If a gear is engaged, the vehicle may only be started by depressing the clutch pedal.

Special note:

- if any of the starting conditions are not met, the "Press brake + START" or "Press Clutch + Start" or "Select Gearbox Position "P"" message is displayed on the instrument panel;
- in some cases, it will be necessary to move the steering wheel whilst pressing the start button **3** to help unlock the steering column: in this case the "Turn Steering Wheel + START" message will inform you;
- when starting the engine in very low exterior temperatures (below -10°C): hold down the clutch pedal or the brake pedal until the engine starts.

STARTING, STOPPING THE ENGINE

Accessories function

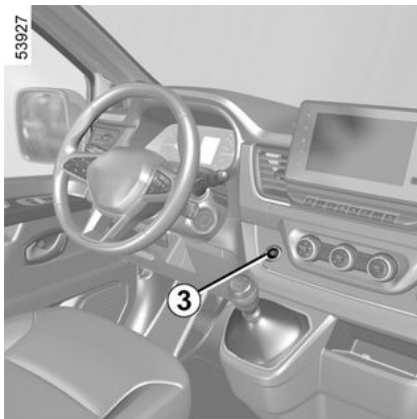

(switching on the ignition)

Once you have gained access to your vehicle, you may use some of its functions (radio, navigation, wipers, etc.).

To use the other functions, with the card in the passenger compartment, press the button **3** without pressing the pedals.

Conditions for stopping the engine



Never switch off the ignition before the vehicle has stopped completely.

Once the engine has stopped, the brake servo, power-assisted steering, etc., and the passive safety devices such as the Airbags and pretensioners will no longer operate.

53723



The vehicle must be at a standstill.

The vehicle must be stationary, with the lever positioned in P or N for vehicles with an automatic gearbox.

The card must be in detection zone **1** for the van version or in detection zone **2** for the combi version. Press button **3**: the engine stops. The steering column is locked when the driver's door is opened or the vehicle is locked.

55547



If the card is no longer in the passenger compartment or if the card's battery is flat, when the vehicle is stationary and you try to switch the engine off, the "Keycard absent : press/hold START" message appears on the instrument panel: press the button **3** for at least three seconds.

With the ignition switched off, any accessories being used (radio etc.) will continue to function for approximately 10 minutes.

STARTING, STOPPING THE ENGINE

When the driver's door is opened, the accessories stop working.

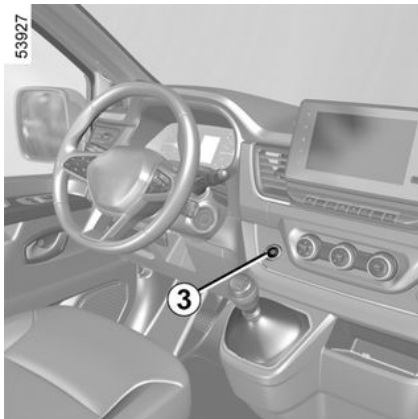

Operating faults

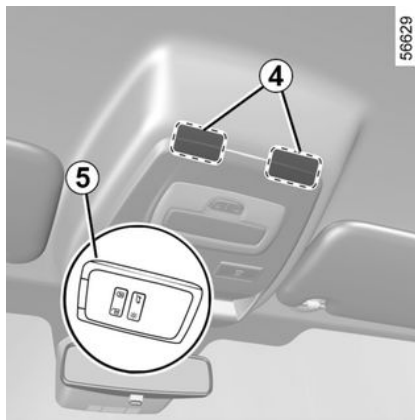

In certain cases, the hands-free card may not work:

- when the card battery is drained, flat battery etc.
- the card is near to appliances operating on the same frequency (monitor, mobile phone, video game device, etc.);
- the vehicle is located in a high electromagnetic radiation zone.

The "Place card on zone + START" message appears on the instrument panel.

Press the brake or clutch pedal, then place the card **5** (button side facing you) at the angle indicated on one of the placement areas **4**. Press the but-

ton **3** to start the vehicle. The message goes out.

Stop and Start Function



To fill up with fuel, the engine must be off (and not only on standby in the case of vehicles equipped with the Stop and Start function): you must switch off the ignition → **179**, → **172**.

Fire hazard.

This system enables a reduced fuel consumption and lower greenhouse gas emissions.

The system is activated automatically when the vehicle is started. While driving, the system stops the engine (standby) when the vehicle is at a standstill (traffic jam, traffic lights, etc.).

Conditions for engine standby



Before leaving the vehicle, the engine must be stopped (not put in standby) → **180**.

STARTING, STOPPING THE ENGINE



Keep your vehicle stationary when the engine is on standby (shown by

the warning light  on the instrument panel).

The vehicle has set off from where it was parked;

For automatic gearboxes:

- the gearbox is in D, M or N position; and
- the brake pedal is pressed. Depending on the vehicle, if the  warning light flashes and the "Press brake pedal" message appears on the instrument panel, this indicates that the brake pedal is not sufficiently pressed; and
- the accelerator pedal is not pressed; and
- the speed is zero.

The engine remains on standby if P position is engaged or if N position is engaged with the parking brake applied and the brake pedal released.

For manual gearboxes:

- the gearbox is in neutral; and
- the clutch pedal is released. Depending on the vehicle, if the  warning light flashes and the "Release Clutch pedal" message is displayed on the instrument panel, this indicates that the clutch pedal is not sufficiently released; and
- the vehicle speed is zero.

For all vehicles:

The warning light  on the instrument panel is lit when the engine is on standby. The vehicle equipment remains operational while the engine is stopped.

When the engine switches to standby, the steering assistance may no longer be operational.

In this case it becomes operational again when the engine is no longer on standby or the speed exceeds approximately 1 mph (1 km/h) (downhill, slope, etc.).

Preventing the engine from standing by

In certain situations, such as negotiating a crossroads for instance, it is possible (with the system activated) to keep the engine on so as to be ready to move off quickly.

For vehicles equipped with automatic gearboxes:

Keep the vehicle stationary without pressing too hard on the brake pedal.

For vehicles equipped with manual gearboxes:

Keep the clutch pedal pressed right down.

Conditions for coming out of engine standby

For automatic gearboxes:

- when the driver's door is opened;
- when the driver's seat belt is unfastened;
- in manual mode, the gear change paddles are activated;
- the brake pedal is released and D or M position is engaged;
- the brake pedal is released, N position is engaged and the parking brake is released;

STARTING, STOPPING THE ENGINE

- the brake pedal is pressed again, P position is engaged or N position is engaged and the parking brake is applied;
- the R position is engaged;
- the accelerator pedal is depressed.

For manual gearboxes:



For vehicles equipped with a manual gearbox

The restart may be interrupted if the clutch pedal is released too quickly while a gear is engaged.



If the engine stalls while the system is in operation, pressing the clutch pedal right down will start it again.

- when opening the driver's door, without any gear engaged and the clutch pedal released;
- when unfastening the driver's seat belt, without any gear engaged and the clutch pedal released;
- the gearbox is in neutral position and the clutch pedal is slightly pressed;

- the engine is in gear and the clutch pedal is pressed right down.

Special feature:

Special note: depending on the vehicle, if you switch off the ignition when



the engine is on standby, the warning light may be displayed for a few seconds on the instrument panel.

Conditions preventing the standby of the engine



Before carrying out any action in the engine compartment, you must switch off the ignition

→ 180.

Certain conditions prevent the system from using the engine standby function, especially when:

For all vehicles:

- the driver's door is not closed;
- the driver's seat belt is not fastened or was not fastened when driving began;
- reverse gear is engaged;
- the Park Assist function is in operation;

- the bonnet is not locked;
- the outdoor temperature is too low or too high;
- the battery is not sufficiently charged;
- the difference between the vehicle interior temperature and the automatic climate control setpoint is too high;
- the altitude is too high;
- the slope is too steep for vehicles fitted with an automatic gearbox;
- the "Clear View" function is activated → 290;
- the engine temperature is too low;
- the emission control system is being regenerated;
- ...



Depending on the vehicle, the warning light appears on the instrument panel to indicate that engine standby is not available. The warning light may appear along with a message on the instrument panel:

- "Battery charge optimisation" to prioritise battery charging;
- "Heating comfort priority" to prioritise the air conditioning;
- "Engine running priority" to prioritise engine functions.

STARTING, STOPPING THE ENGINE

Special feature of the automatic engine re-start



Before leaving the vehicle, the engine must be stopped (not put in standby) → 180.

Under certain conditions, the engine can restart on its own in order to guarantee your safety and comfort.

This may occur when:

- the outdoor temperature is too low or too high;
- the "Clear View" function is activated → 290;
- the battery is not sufficiently charged;
- the vehicle speed is above 3 mph (5 km/h) (downhill slope, etc.);
- the brake pedal is pressed repeatedly or there is a braking system requirement;
- ...

Depending on the vehicle, the  warning light is displayed on the instrument panel to notify you of automatic engine restarting.

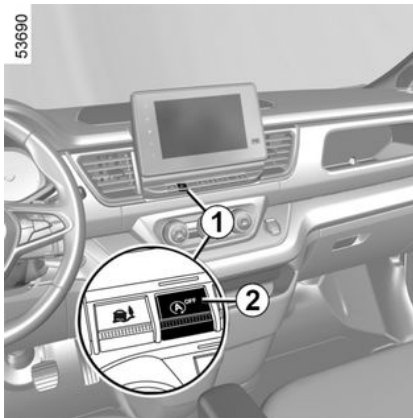

Depending on the vehicle, the  warning light may be accompanied by a message on the instrument panel:

- "Battery charge optimisation" to prioritise battery charging;
- "Heating comfort priority" to prioritise the air conditioning;
- "Engine running priority" to prioritise engine functions.



Special note: with the engine on standby, press switch **1** to automatically restart the engine.

Deactivating, activating the function

Press the switch **1** to deactivate the function. The "Stop & Start deactivated" message appears on the instrument panel and the built-in indicator light **2** on the switch **1** lights up.

Pressing again will reactivate the system. The "Stop & Start Activated" message appears on the instrument panel and the built-in indicator light **2** on the switch **1** goes out.

The system is automatically reactivated each time the vehicle is deliberately started → 180.

Operating faults

When the "Check Stop & Start" message appears on the instrument panel, accompanied by the illumination of the built-in indicator light **2** on the switch **1**, this indicates that the system is deactivated.

Consult an approved dealer.

GEAR CONTROL

Gearstick

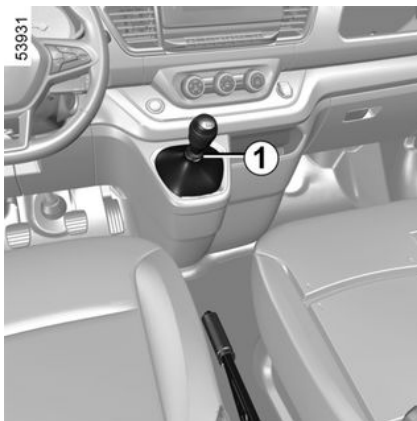

When stationary and depending on the road gradient and/or vehicle load, it may be necessary to pull up the parking brake at least two extra notches and engage a gear (1st or reverse gear) on vehicles with a manual gearbox or P position on vehicles fitted with an automatic gearbox.



An impact to the underside of the vehicle (e.g. striking a post, raised kerb or other street furniture) may result in damage to the vehicle (e.g. deformation of an axle).

To avoid any risk of accident, have your vehicle checked by an approved dealer.

Selecting reverse gear

Vehicle with a manual gearbox: shift the lever to Neutral, then shift the lever to Reverse.

The ring **1** has to be lifted up to the gear lever knob in order to engage reverse gear.

Vehicles with an automatic gearbox
→ **188.**

The reversing lights will come on as soon as reverse gear is selected (with the ignition on).

Vehicles equipped with Park Assist
→ **269.**

Automatic gearbox



An impact to the underside of the vehicle while manoeuvring (e.g. striking a post, raised kerb or other street furniture) may result in damage to the vehicle (e.g. deformation of an axle).

To avoid any risk of accident, have your vehicle checked by an approved dealer.



For safety reasons, do not switch off the ignition before the vehicle has come to a complete standstill.



Check that the P warning light is displayed on the instrument panel before leaving the vehicle.

Risk of loss of immobilisation of the vehicle

GEAR CONTROL

Selector lever 1



- P:** park
- R:** reverse gear
- N:** neutral
- D:** automatic mode
- M:** manual mode
- +**: shift up a gear
- : shift down a gear

The gear that is currently engaged is displayed on instrument panels **A** or **B**.

Note: press button **2** to change from position D or N to R or P.

Operation

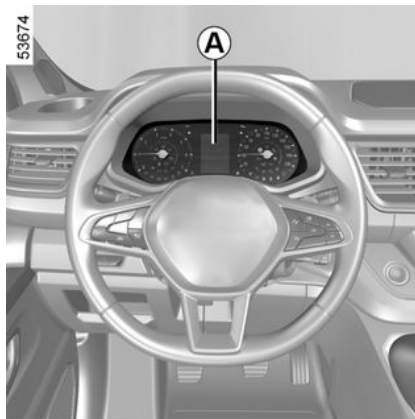

With the selector lever **1** in P position, start the engine.

To move out of P position, you must press the brake pedal before pressing the unlocking button **2**.

With your foot on the brake pedal (the



warning light on the display goes out), disengage P position.

The lever must only be shifted to D or R position while the vehicle is stationary, your foot is on the brake pedal, the accelerator pedal is released and the engine is on.

Driving in automatic mode

Set the lever **1** to D position.

In the majority of driving conditions, you will no longer have to use your gear lever: the gears change automatically, at the right time, to a suitable engine speed because the automated system takes the vehicle's load, road profile and the selected driving style into account.



In some cases (parked on a steep slope, etc.), a lot of the force may be required to move the gear lever from P position to another position.

Driving in automatic mode (cont.)

Economical driving

When driving, always leave the lever in position D, keeping the accelerator pedal lightly depressed to ensure automatic gear changes at a lower engine speed.

Accelerating and overtaking

Depress the accelerator pedal briskly and fully (so that it goes beyond the kickdown point).

GEAR CONTROL

This will enable you to change down to the optimum gear within the engine range.

Driving in manual mode



Shift the selector lever **1** to D position, then shift the lever to the right to M position.

Shifting the lever repeatedly allows you to change gears manually:

- to move down through the gears, push the lever forwards;
- to move up through the gears, push the lever backwards.

The gear selected is displayed on the instrument panel.

Special cases

In certain driving conditions (resulting in, for example, engine protection, activation of the electronic stability control (ESC), etc.), the automatic system may change the gear automatically.

Likewise, to prevent incorrect manoeuvres, a gear change may be refused by the automatic system: in this case the gear display flashes for a few seconds as a warning.

Special circumstances

- **If the road surface and bends** do not allow you to stay in automatic mode (e.g. when driving in the mountains), we recommend that you change to manual mode. This will prevent the "automatic gearbox" from changing gears repeatedly when driving uphill, and permit engine braking on long descents.
- **In cold weather**, start the engine and wait a few seconds before disengaging P or N position and shifting the lever to D or R position.



When facing uphill, to remain stopped, do not keep your foot on the accelerator.

Risk of overheating the automatic gearbox.

Parking the vehicle

When the vehicle is stationary, move the lever to P position while keeping your foot on the brake pedal: the drive wheels are mechanically locked by the driveshaft.

Ensure that the electronic parking brake is engaged.

Note: if the vehicle is parked on a steep slope with P position engaged, the "WARNING: Apply Parking Brake" message appears on the instrument panel accompanied by a beep.

Maintenance period

Refer to the maintenance document for your vehicle or consult an Approved Dealer to check whether the automatic gearbox requires scheduled maintenance.

If it does not need to be serviced, there is no need to top up the oil.

GEAR CONTROL

Operating faults

- **during driving**, if the "WARNING: Check Gearbox" message appears on the instrument panel, this indicates a fault. Contact an approved dealer as soon as possible;
- **when driving**, if the "WARNING: Gearbox Overheating" message appears on the instrument panel, stop as soon as possible to let the gearbox cool down and wait for the message to disappear;
- **Troubleshooting on a vehicle with an automatic gearbox** → 349.

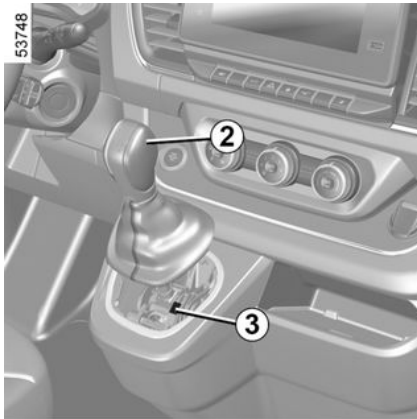

When setting off, if the lever is locked in position P even though you are pressing the brake pedal, the lever can be released manually. To do this, un-

clip the base of the lever then place a tool (rigid shaft) into the slot **3** (located to the left or right of the lever). Press simultaneously on the tool (rigid shaft) and the button **2** to unlock the lever.

Contact your approved Dealer as soon as possible;

SPECIAL FEATURES OF DIESEL VERSIONS

Diesel engine speed



Do not park the vehicle or run the engine in locations where combustible substances or materials such as grass or leaves can come into contact with the hot exhaust system.

When driving, to avoid damaging the engine, never let the engine speed exceed 4,500 rpm, regardless of which gear is engaged.

If the "Check Anti- Pollution System" message is displayed along with the



and warning lights, consult an approved dealer immediately.

When driving, depending on the grade of fuel used, it is possible that white smoke may be emitted.

This is due to the exhaust particle filter being cleaned automatically, and does not affect the way the vehicle runs.

Running out of fuel

After the tank has been filled following a **complete draining of fuel**, the fuel

system → 172 must be reprimed before starting the engine.

Engine smoke opacity label

43218-2



You can find the information **1** on the label **A** affixed in the engine compartment or, depending on the vehicle, on the vehicle identification plate → 375.

1. Diesel exhaust emissions.

Precautions to be taken in winter



Do not park the vehicle or run the engine in locations where combustible substances or materials such as grass or leaves can come into contact with the hot exhaust system.

To avoid any faults in icy weather:

- ensure that the battery is always fully charged;
- always keep the diesel tank relatively full to avoid water vapour condensing in it and accumulating at the bottom of the tank.

Particle filter

The particle filter is used in the treatment of exhaust gases from diesel engines.

Depending on the vehicle, the warning



light displayed on the instrument panel indicates that the filter is becoming clogged and requires cleaning.

Note: depending on the vehicle, when the particle filter is operational and does not require any action by the dri-

SPECIAL FEATURES OF DIESEL VERSIONS

ver, the "DPF regeneration not needed" message is displayed on the instrument panel to inform them.

Automatic regeneration

To do this, when the  warning light is displayed, continue driving according to traffic conditions and observe the speed limit until the warning lights disappears. If possible, do not let the engine speed drop below 2,000 rpm.

The warning light should go out after approximately 10 to 20 minutes → 145.



To facilitate the automatic particle filter regeneration, carry out a long driving phase (at least 20 minutes) on main roads every 124 miles (200 km).

The display of the  warning light on the instrument panel may be accompanied by an increase in engine speed and operation of the cooling system in order to clean the particle filter.

Note: the warning light may reappear if the driving conditions are not fully met with regard to cleaning the filter. If the vehicle is stopped or the engine speed is below 2,000 rpm before the warning light is switched off you may have to restart the operation.

Manual regeneration

(depending on the vehicle)



Do not start the regeneration in a garage or a confined area.

Risk of poisoning or suffocation by exhaust gas emissions.

Make sure that no one is near the exhaust when regenerating.

Risk of burns.

Do not park the vehicle in locations where combustible substances or materials such as grass, leaves or paper may come into contact with or be near to the hot exhaust system.

Fire hazard.

Do not leave your vehicle unattended during regeneration.

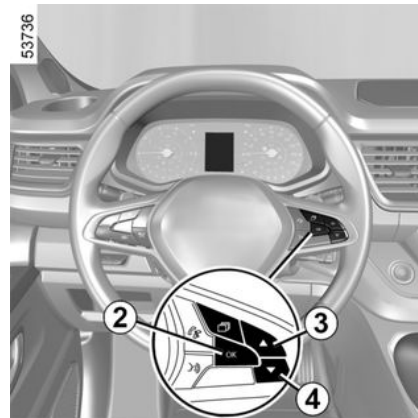

If it is not possible to comply with the conditions (driving time required, etc.),

the warning  light displayed on the instrument panel comes on, accompanied by the message "Regenerate the particle filter" to indicate that the saturation level is too high for automatic regeneration.

You must quickly carry out manual regeneration to avoid saturation of the particle filter which may require you to consult an approved dealer.

Manual regeneration of the particle filter leads to high temperature in the exhaust system and exhaust gases. Precautions must be taken into account

SPECIAL FEATURES OF DIESEL VERSIONS

during the process which lasts for approximately 40 minutes.

To do this, when the warning light



comes on, accompanied by the message "Regenerate the particle filter":

- park your vehicle off the road, away from traffic and in a place where it is at least three metres from any obstacles or material which could easily ignite or melt (e.g. paper, grass, plastic, dry organic material, etc.);
- apply the parking brake;
- Set the gear lever to neutral (position N on vehicles with an automatic gearbox).

Then, with the engine on:

- deactivate the Stop and Start → 184 function (if the vehicle is equipped);
- go to the "Vehicle" tab in the instrument panel menu → 136;
- press button **3** or **4** repeatedly until the "Regenerate DPF [long press]" message appears;
- press and hold button **2** until the "DPF regeneration Ongoing" or "Regen 40min-to stop press brake" message appears.

The warning light



flashes. Wait until the warning light goes out (approximately 40 minutes). The "DPF

Regeneration Completed" message is displayed on the instrument panel.

If the conditions are not met before or during regeneration, the warning light



goes out and the message "DPF Regeneration Interrupted" is displayed and the procedure is cancelled.

The "Regenerate DPF [long press]" message will be displayed as soon as the conditions required to renew the manual procedure are once again met.

Note: do not start the regeneration in the event of an insufficient oil or coolant level (oil pressure warning light



or coolant temperature warning light  lit on the instrument panel). In this case, top up → 324 and → 327.

Regeneration is not possible:

- if the fuel level is too low;
- if the engine is too cold;
- in extreme weather conditions (cold, hot or very high altitude).

During the regeneration process:

- the engine speed first increases to approximately 3,000 rpm in order to warm the engine. It then decreases to approximately 2,000 rpm until the end of the regeneration;

- the fan assemblies are triggered. This is a normal operation to ensure engine cooling;
- white fumes and unusual odours are frequently produced in the exhaust system. This does not indicate that the system is operating incorrectly.

If you need to interrupt the particle filter regeneration, press one of the pedals. In this case, regeneration will only be partial.

Special cases





For your own safety, the



warning light

requires you to stop immediately, as soon as traffic conditions allow. Switch off the engine and do not restart it. Call an approved dealer.

If the filter becomes excessively saturated, the  warning light and,

depending on the vehicle, the  warning light will appear on the instrument panel, accompanied by the "Check injection" message. In this

SPECIAL FEATURES OF DIESEL VERSIONS

case, please consult an Authorised Dealer.

If the  warning light and, de-

pending on the vehicle, the  warning light appear accompanied by the "WARNING: Engine Failure Risk" message, stop the vehicle and contact an approved dealer.

PARKING BRAKE

Handbrake

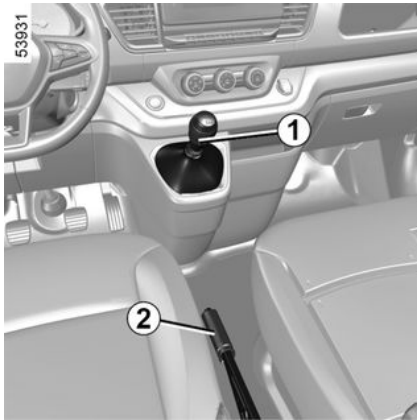

Make sure that the handbrake is properly released when driving (red indicator light off), otherwise overheating may occur.

To release

Pull the lever slightly upwards, press the button **2** and then lower the lever to the floor.

The red warning light on the instrument panel will come on if you are dri-

ving with an incorrectly released handbrake.

To apply:

Pull the lever upwards and make sure the vehicle is immobilised.

ENVIRONMENT

Manufacture

Your vehicle has been designed with respect for the **environment** in mind for its entire service life: during its production, usage and at the end of its service life.

Your vehicle has been manufactured at a factory which complies with a policy to reduce the environmental impact on the surrounding areas (reduction of water and energy consumption, visual and noise pollution, atmospheric emissions and waste water; sorting and reusing waste).

Emissions

Your vehicle has been designed to emit fewer greenhouse gases (CO₂) while in use and therefore to consume less fuel (e.g. 225 g/mile (140 g/km), equivalent to 1.17 gal/62 miles (5.3 l/100 km) for a diesel vehicle).

Our vehicles are also equipped with a particle filter system including a catalytic converter, an oxygen sensor and an active carbon filter (the latter prevents vapour from the fuel tank being released into the open air).

For certain diesel vehicles, this system also has a particle filter to reduce the volume of soot particles emitted.

Please make your own contribution towards protecting the environment too.

– Parts and vehicles at the end of their life must not be thrown away. They must be handed to a legal entity that complies with environmental standards.

26913



– Worn parts and components that are replaced during routine vehicle maintenance, such as tyres or oil (tanks emptied or filled) must be disposed of at dedicated collection points.

– Worn electrical and electronic components that are replaced (such as batteries) must not be thrown away as rubbish. Take them to an approved dealer or consult your local authority

for information on appropriate recycling facilities.

– To optimise the recycling of your vehicle at the end of its life, you can contact an approved dealer or visit the manufacturer's website to be directed to collection points that guarantee respect for the environment according to local laws.

Recycling

Your vehicle is at least 85% recyclable and at least 95% recoverable.

To achieve these objectives, many of the vehicle components have been designed to enable them to be recycled. The materials and structures have been carefully designed to:

– allow these components to be easily removed and reprocessed by specialist companies;

– promote a circular economy (re-use, recycling, recovery, etc.)

This is particularly true for electrified vehicle batteries.

In order to preserve raw material resources, this vehicle incorporates numerous parts made from recycled plastics or renewable materials (vegetable or animal-derived materials such as cotton or wool).

MAINTENANCE AND ANTIPOLLUTION ADVICE

Introduction

Your vehicle complies with criteria for recycling and recovering vehicles at the end of their service life, which entered into force in 2015.

Some of the parts on your vehicle have been designed to be recycled later.

These parts are easily removable in order to be collected and reprocessed in recycling networks.

Furthermore, by virtue of its design, moderate fuel consumption and initial settings, your vehicle also conforms to current anti-pollution regulations. The manufacturer is actively striving to reduce pollutant exhaust gas emissions and to save energy. But the fuel consumption of your vehicle and the level of pollutant exhaust gas emissions are also your responsibility. Ensure that it is maintained and used correctly.

Maintenance

It is important to remember that failure to respect antipollution regulations could lead to legal action being taken against the vehicle owner. In addition, replacing engine, fuel supply system and exhaust components with parts other than those originally recommended by the manufacturer may alter

your vehicle so that it no longer complies with antipollution regulations.

Have your vehicle adjusted and checked by an approved dealer, in accordance with the instructions given in your maintenance schedule: they will have all the equipment necessary for ensuring that your vehicle is maintained to its original standard.

Engine adjustments

- **Air filter, diesel filter:** a clogged filter hinders performance. It must be replaced.
- **Idle speed:** this does not require adjustment.

Exhaust gas monitoring system

The exhaust gas monitoring system will detect any operating faults in the vehicle's exhaust gas antipollution system.

If this system malfunctions, toxic substances may be released into the atmosphere or mechanical damage may occur.



This warning light on the instrument panel indicates possible faults in the system: it lights up when the ignition is switched on then goes out when the engine starts.

- If it lights up continuously, contact an approved dealer as soon as possible;
- If it flashes, reduce the engine speed until the light stops flashing. Contact your approved Dealer as soon as possible;



→ 175

DRIVING ADVICE, ECO-DRIVING

Introduction

Fuel consumption is accredited in accordance with a standard regulatory method. Identical for all manufacturers, this enables vehicles to be compared with one another. Consumption in real time depends on vehicle usage conditions, the equipment fitted and the user's driving style. To optimise fuel consumption, please refer to the following advice.

Depending on the vehicle, there may be different functions available to help you reduce your fuel consumption:

- the rev counter;
- the "free-wheel" function;
- performance mode;
- the gear change indicator;
- the driving style indicator;
- the journey record and eco-driving advice via the multimedia screen;
- ECO mode activated by the ECO or Drive mode button;
- the Stop and Start ➔ **184** function.

If fitted on the vehicle, the navigation system provides additional information.

"Free-wheel" function

Depending on the vehicle, on vehicles fitted with an automatic gearbox and with ECO mode activated, during deceleration phases (driver's foot fully off

the accelerator pedal), switching to freewheeling (automatic neutral) allows you to move farther without accelerating in order to save fuel.

The  indicator light is displayed on the instrument panel in green (or in white, depending on the vehicle) when the vehicle is freewheeling (automatic neutral).

Note: the "free-wheel" function is deactivated when the brake pedal is pressed or when the accelerator pedal is pressed.

Performance mode

If your vehicle is equipped and if driving under-load, the "Performance mode" function enables you to limit under-revving, gives priority to engine braking when decelerating and enables more dynamic engine driving.

Nota : performance mode is only available for vehicles fitted with an automatic gearbox ➔ **188**.

Activation, deactivation of performance mode

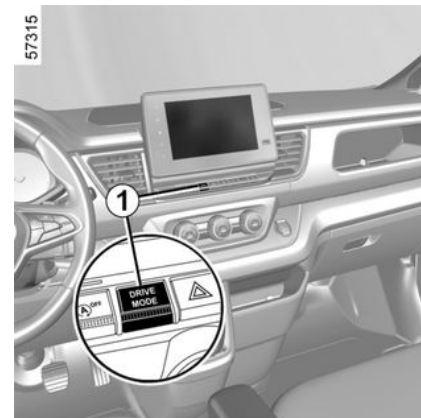

Press button **1** until the "Perfo" message is displayed in zone **2** on the instrument panel to confirm the activation.

Press button **1** again as many times as necessary to return to "Normal" mode. The "Perfo" indicator light goes out to confirm deactivation.

DRIVING ADVICE, ECO-DRIVING



Gear change indicator 3



Driving style indicator 4



Each time the engine is switched off, performance mode will be deactivated and it will be necessary to select it again.

Performance mode may be used to equal effect in both automatic and manual modes.

Depending on the vehicle, to obtain optimum consumption levels, a warning light on the instrument panel lets you know the best time to move up or down a gear:



shift up a gear;



downshift a gear.

Informs you about the driving style adopted in real time. You will be notified by the size of the indicator light 4.

- **Large:** measured, economical driving;
- **Medium :** a fairly measured driving style;
- **Small:** driving too erratically.

To **activate/deactivate** the driving style indicator, please see the multimedia system instructions.

DRIVING ADVICE, ECO-DRIVING

ECO mode

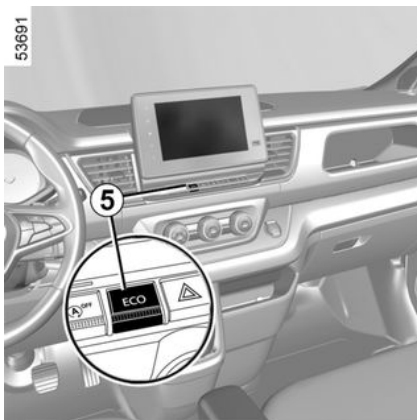

ECO mode is a function which optimises fuel consumption. It affects certain driving operations (acceleration, shifting gears, cruise control, deceleration, etc.).

Limiting acceleration enables low fuel consumption in urban and surrounding areas.



Activating the function

Press switch **5** until the warning light **6** ECO is displayed on the instrument panel to confirm the activation.

While driving, it is possible to exit the ECO mode temporarily in order to improve engine performance.

To do this, press the accelerator pedal firmly and fully.

ECO mode is reactivated when you take pressure off the accelerator pedal.

Deactivating the function

Press switch **5** as many times as necessary to return to normal mode.

Warning light **6** ECO goes out on the

instrument panel to confirm deactivation.

Note: on vehicles equipped with an automatic gearbox, each time the engine is switched off ECO mode will be deactivated and it will be necessary to activate it again.

Driving advice, Eco-driving



Driver obstruction

On the driver's side, only use mats suitable for the vehicle, attached with the pre-fitted components, and check the fitting regularly. Do not lay one mat on top of another.

There is a risk of wedging the pedals.

DRIVING ADVICE, ECO-DRIVING

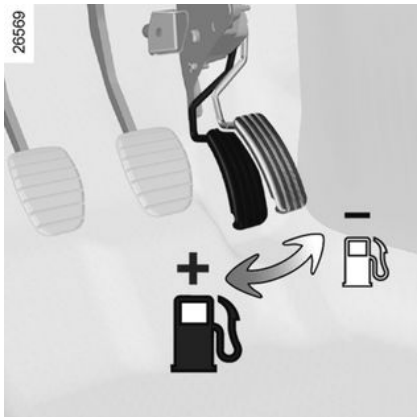

Behaviour

- Drive carefully until the engine reaches its normal operating temperature, rather than let it warm up while the vehicle is stationary.
- Dynamic driving involving heavy and frequent acceleration and braking is expensive on fuel in comparison to the time saved.
- High speeds significantly affect the vehicle's fuel consumption. Examples (at a steady speed):
 - reducing the speed from approximately 80 mph (130 km/h) to 68 mph (110 km/h) saves up to around 20% of fuel;
 - reducing the speed from approximately 56 mph (90 km/h) to 50 mph

(80 km/h) saves up to around 10% of fuel.

- Do not over rev the engine in the intermediate gears. You should always use the highest gear possible.
- Avoid sudden acceleration.
- Brake as little as possible. If you anticipate an obstacle or bend in advance, you may then simply release the accelerator pedal.
- Do not try to maintain the same speed up a hill, accelerate no more than you would on level ground. Keep your foot in the same position on the accelerator pedal.
- Double declutching and accelerating before switching off the engine are unnecessary in modern vehicles.
- Bad weather, flooded roads:



Do not drive through water if it is higher than the lower edge of the wheel rim.

Heating levels

It is normal to notice an increase in the vehicle's fuel consumption when using the heating (particularly when the outside temperature drops below zero) or air conditioning.

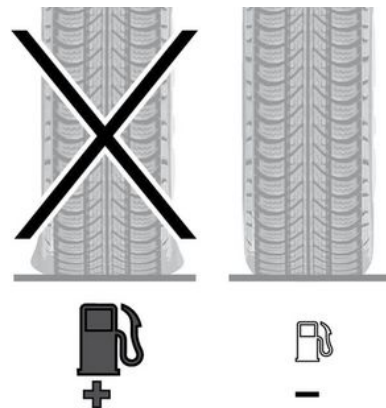

Tyres

- An underinflated tyre increases fuel consumption.
- The use of non-recommended tyres can increase fuel consumption.

DRIVING ADVICE, ECO-DRIVING

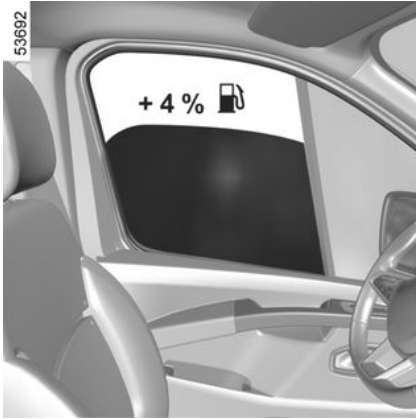

Advice on use

- Opt for ECO mode.
- Electricity is fuel – switch off all the electrical components when they are not genuinely needed. **However** (safety first), keep your lights on when the visibility is bad ("see and be seen").
- Use the air vents. Driving with the windows open at 62 mph (100 km/h) will increase fuel consumption by 4%.
- Never fill the fuel tank right to the brim to avoid overflow.
- **On vehicles equipped with non-automatic air conditioning**, switch off the air conditioning when it is not required.

Advice for reducing consumption and helping to preserve the environment:

- If the vehicle has been parked in the sun, open the doors for a few moments to let the hot air escape before starting the engine.
- Do not leave an empty roof rack fitted to the vehicle.
 - It is better to fit a trailer for bulky objects.
 - When towing a caravan, fit a wind deflector and adjust it carefully.
 - Avoid using the vehicle for "door-to-door" calls (short journeys with long waits in between) because in such conditions the engine never reaches its optimal operating temperature.

TYRE PRESSURE MONITORING SYSTEM

Operating principle

If the vehicle is equipped with the function, this system monitors the tyre pressure.

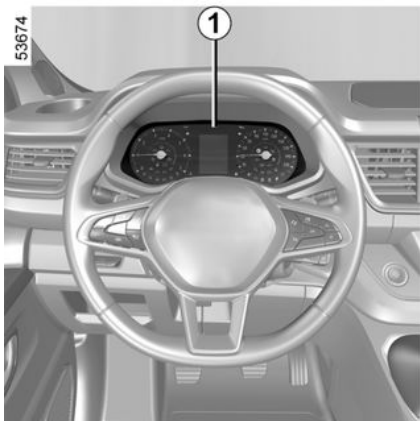

Each wheel (except for the emergency spare wheel) has a sensor in the inflation valve which periodically measures the tyre pressure.

The system displays the current pressures on the instrument panel **1** and alerts the driver in the event of insufficient pressure.

Resetting the standard level for the tyre pressures

This should be performed:

- when the standard tyre pressure needs to be changed to adapt to usage conditions (empty, carrying a load, motorway driving, etc.);
- after swapping a wheel (however, this practice is not recommended);
- after changing a wheel.

It should always be done after checking the tyre pressure of all four tyres when cold.

Tyre pressures must correspond to the current usage of the vehicle (empty, carrying a load, motorway driving, etc.).



If the wheels are swapped, the system must be reinitialised. Consult an approved dealer.

Resetting procedure

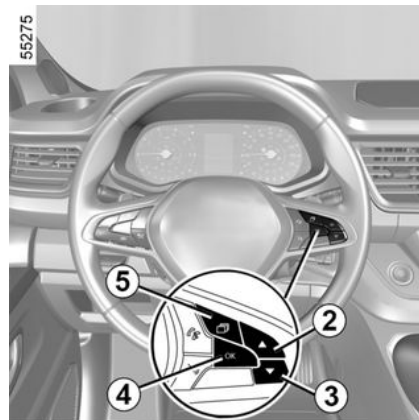

Ignition on, **vehicle stopped**:

- press switch **5** as many times as necessary to reach the "VEHICLE" tab



- briefly press switch **2** or **3** repeatedly to reach the "Tyre Pressure" page;
- press and hold (around 3 seconds) on the control **4** to launch the reset. The flashing tyres symbol followed by the "Learning Tyre Pressures" message indicates that the request to reset the tyre pressure has been acknowledged.

Reset can take several minutes of driving.

TYRE PRESSURE MONITORING SYSTEM

If the reset is followed by short journeys, the display of step 3 in the table may remain displayed after several successive restarts.

Note: the tyre pressure reference value cannot be less than that recommended and indicated on the door frame.







For your safety, the warning light **STOP** requires you to stop immediately as soon as traffic conditions allow.

TYRE PRESSURE MONITORING SYSTEM

Resetting the tyre pressure reference value: table

The table below shows the possible messages related to the tyre resetting procedure.

Steps	Displays (depending on the vehicle)	Messages	Readings
1		Tyre pressure init. long press	With the ignition on and the vehicle stationary, start resetting the pressure of all four tyres by pressing and holding the 4 OK switch.
2		Learning Tyre Pressures	The "---" symbols in front of each wheel will flash to indicate that the system has registered the tyre pressure reset for all four wheels.
3			The "---" symbols in front of each wheel will remain lit. This system resets the tyre pressure of all four tyres. You can now drive. Note: during the reset, tyre pressure monitoring remains in operation.
4			The pressure value of the four tyres is displayed: the resetting procedure is complete and successful.

TYRE PRESSURE MONITORING SYSTEM

Readjustment of tyre pressures



This function is an additional driving aid.

The function does not take the place of the driver. It cannot, therefore, under any circumstances replace the vigilance or the responsibility of the driver. Check the tyre pressures, including the emergency spare wheel, once a month.

The pressure of the four tyres must be set when cold (refer to the label located on the edge of the driver's door). If the tyre pressures cannot be checked when they are cold, the recommended pressures should be increased by 0.2 to 0.3 bar (3 PSI).

Never deflate a hot tyre.

Emergency spare wheel

If the vehicle is equipped with an emergency spare wheel, it will not have a sensor.

Replacing wheels/tyres



Changing a wheel

The system may take several minutes depending on use for the new wheel positions and pressures to be recognised; check the tyre pressures after all operations.

This system requires specific equipment (wheels, tyres, wheel rims, etc.) → 336.

Contact an approved dealer to replace the tyres and to find out about accessories compatible with the system that are available from the brand's network: using any other accessory could affect the correct operation of the system.

Tyre repair product and inflation kit

Because the valves are specially designed, only use equipment approved by the approved network. Please see the paragraph on → 339.

Tyre pressure faults

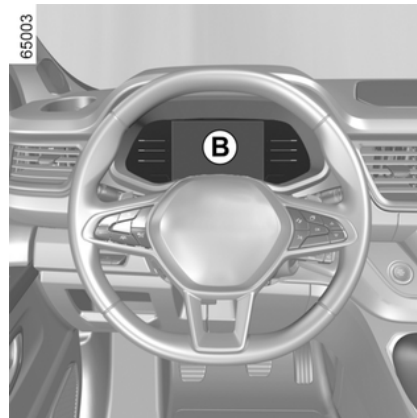
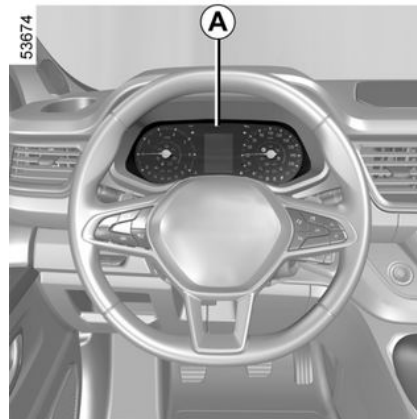

TYRE PRESSURE MONITORING SYSTEM

The following table lists the warning messages which appear on instrument panels **A** and **B** if the system detects a tyre pressure fault.











The information on the instrument panel signals any potential tyre pressure faults (e.g. deflated or punctured tyre). For your safety, the

warning light  requires you to stop immediately as soon as traffic conditions allow.

3

TYRE PRESSURE MONITORING SYSTEM

Fault message table

Indicator lights	Messages	Displays (depending on the vehicle)	Readings
 lights up and stays on.	Adjust Tyre Pressure		The wheel and associated pressure value are displayed in yellow. This indicates that tyre under-inflation has been detected. Check and adjust the pressure of the four tyres then reset the system.
 +  light up and stay on.	Puncture		The wheel and associated pressure value are displayed in red. This indicates that the tyre concerned is punctured or severely underinflated. Adjust the pressure of the four tyres while cold and reset the system if the tyre is deflated. Replace the tyre (or have it replaced) if it is punctured.
 flashes, then stays on, along with the warning light 	Check Tyre Pressure Sensors		One or more wheels are no longer displayed. This indicates that at least one wheel is not fitted with a sensor (e.g. emergency spare wheel) or that the sensor is faulty. Consult an approved dealer.
 lights up and stays on.			This indicates that the system has not been able to determine the pressure of each tyre. This may be caused by the use of a sensor not recommended by an approved dealer. The tyre pressure sensor monitoring system remains in operation.

DRIVER CORRECTION DEVICES AND AIDS

Introduction



These functions are an additional aid in the event of critical driving conditions, enabling the vehicle behaviour to be adapted to suit the driving conditions. The functions do not take the place of the driver. **They do not increase the vehicle's limits and should not encourage you to drive more quickly.** Therefore, they can under no circumstances replace the vigilance or responsibility of the driver when manoeuvring the vehicle (the driver must always be ready for sudden incidents which may occur when driving).

Depending on the vehicle, they may include:

- **an anti-lock braking system (ABS);**
- **electronic stability control (ESC) with understeer control and traction control;**
- **driver assistance with a trailer;**
- **emergency brake assist;**

- **the traction control;**
- **hill start assistance.**

Anti-lock braking system (ABS)



In an emergency, apply **firm and continuous pressure** to the brake pedal.

There is no need to pump it repeatedly. The ABS will modulate the force applied in the braking system.



Your braking systems are partially operational. However, **it is dangerous to brake suddenly**

and it is essential to stop immediately, as soon as traffic conditions allow. Call an approved dealer.



Under heavy braking, the ABS prevents the wheels from locking, allowing the stopping distance to be managed and keeping control of the vehicle.

Under these circumstances, the vehicle can be steered to avoid an obstacle whilst braking. In addition, this system can increase stopping distances,

particularly on roads with low surface grip (wet ground etc.).

You will feel a pulsation through the brake pedal each time the system is activated. The ABS does not in any way improve the vehicle's "physical" performance relating to the road surface and roadholding. It is still **essential** to follow the rules of good driving practice (such as driving at a safe distance from the vehicle in front etc.).

Operating faults:

–  and  lit up on the instrument panel accompanied by the "Check ABS", "WARNING: Check Braking System" and "Check ESC" messages: this indicates that the ABS, the ESC and the Emergency Brake Assist functions are deactivated. **Braking is still provided;**

– , ,  and

STOP lit on the instrument panel accompanied by the "WARNING: Braking System" message: **this indicates a fault with the braking system.**

In both cases, please consult an Authorised Dealer.

DRIVER CORRECTION DEVICES AND AIDS

Electronic stability control (ESC) with understeer control and traction control

Electronic stability program ESC

This system helps you to keep control of the vehicle in critical driving conditions (avoiding an obstacle, loss of grip on a bend, etc.).

Operating principle

A sensor in the steering wheel detects the direction selected by the driver.

Other sensors throughout the vehicle measure the actual direction.

The system compares driver input to the actual trajectory of the vehicle and corrects the trajectory if necessary by controlling the braking of certain wheels and/or engine power. In the event that the system is engaged, indi-

cator light  flashes on the instrument panel.

Understeer control

This system optimises the action of the ESC in the case of pronounced understeering (loss of front axle road holding).

Traction control

This system helps to limit wheelspin of the drive wheels and to control the vehicle when pulling away, accelerating or decelerating.



Operating principle

Using the wheel sensors, the system measures and compares the speed of the drive wheels at all times and slows down their over-rotation. If a wheel is starting to slip, the system brakes automatically until the drive supplied becomes compatible with the level of grip under the wheel again.

The system also adjusts the engine speed to the grip available under the wheels, independently of the pressure exerted on the accelerator pedal.

Operating faults

When the system detects an operating fault, the "Check ESC" message and

the  and  warning lights appear on the instrument panel. In this case, the ESC and traction control system are deactivated.

Consult an approved dealer.

Driver assistance with a trailer

This system helps to maintain control over the vehicle while using a trailer. It detects shaking caused by towing a trailer under certain driving conditions.

Operating conditions

- The towbar must be approved by an authorised dealer;
- the harness must be approved by an authorised dealer;
- the towbar must be connected to the vehicle.

Operating principle

The function stabilises the vehicle by:

- asymmetric braking of the front wheels to reduce shaking caused by the trailer;
- braking of all four wheels and limitation on engine torque to reduce the vehicle speed until the shaking has stopped.

Warning light  flashes on the instrument panel to inform the driver.

Emergency brake assist

This system supplements the ABS and helps reduce vehicle stopping distances.

DRIVER CORRECTION DEVICES AND AIDS

Operating principle

The system is for detecting an emergency braking situation. In this case, the braking assistance immediately develops maximum power and may trigger ABS regulation.

ABS braking is maintained as long as the brake pedal is applied.

Brake lights come on

Depending on the vehicle, these may flash in the event of sudden deceleration.

Braking anticipation

Depending on the vehicle, when you rapidly release the accelerator, the system anticipates the braking manoeuvre in order to reduce stopping distances.

When using the cruise control:

- if you use the accelerator pedal, when you release it the system may be triggered;
- if you do not use the accelerator, the system will not be triggered.

Operating faults

When the system detects an operating fault, the "WARNING: Check Braking System" appears on the instrument

panel along with the  warning light.

Consult an approved dealer.

Traction control

If fitted on the vehicle, traction control makes it easier to control the vehicle on low grip surfaces (soft ground, etc.).

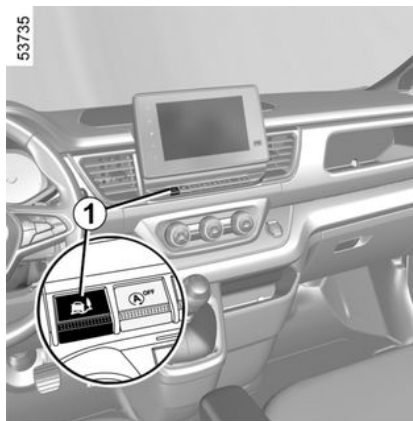

"Automatic" mode

The default "Automatic" mode enables optimal use under normal road conditions (dry, wet, light snow, etc.).

"Automatic" mode uses traction control functions.



The function is reactivated automatically when the ignition is switched on or when a speed of approximately 25 mph (40 km/h) is exceeded.

"Soft ground" mode

Press and hold switch **1**: the "Soft ground mode activated" message is displayed on the instrument panel and

the  warning light or, depending

on the vehicle, the  warning light come on.

This position enables optimal usage on soft ground (mud, sand, dead leaves, etc.). In this position, engine speed is left under the driver's control. The system automatically switches to "Automatic" mode when the speed exceeds approximately 25 mph (40 km/h).

If the switch **1** is pressed again, the



warning light and, depending on

the vehicle, the  warning light(s) is/are switched off and the "Automatic mode activated" message is displayed on the instrument panel to warn you.

DRIVER CORRECTION DEVICES AND AIDS



Activating the "Soft ground" mode causes a temporary unavailability of certain driving aids (Active Emergency Braking, etc.).

Hill start assistance



The hill start assistance system cannot completely prevent the vehicle from rolling backwards in all situations (extremely steep gradients etc.).

In all cases, the driver may depress the brake pedal to prevent the vehicle from rolling backwards.

The Hill Start Assist function should not be used for prolonged stops: use the brake pedal.

This function is not designed to immobilise the vehicle permanently.

If necessary, use the brake pedal to stop the vehicle.

The driver must remain particularly vigilant when driving on slippery or low-grip surfaces.

Risk of serious injury.

Depending on the gradient of the incline, this system assists the driver when starting on a hill. It prevents the vehicle from rolling backwards, depending on the slope, by automatically

applying the brakes when the driver lifts his/her foot off the brake pedal to depress the accelerator pedal.

System operation

It only operates when the gear lever is in a position other than neutral and the vehicle is completely stationary (brake pedal depressed).

The system holds the vehicle for approximately **2 seconds**. The brakes are then gradually released (the vehicle will move according to the slope).

ADDITIONAL DRIVING AID FUNCTIONS

My Safety

The "My Safety" function can be used to deactivate or activate a set of driver assistance functions simultaneously.

Depending on the vehicle, you can configure the My Safety function from the multimedia screen or from the instrument panel by selecting the driving aid functions to be switched off as a group.

Operation

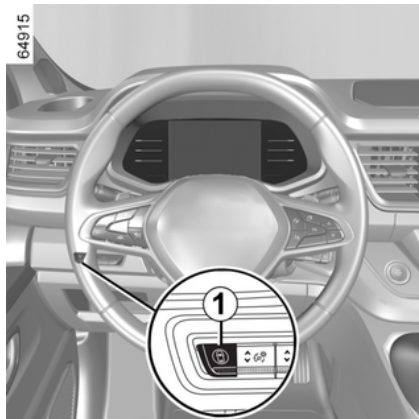

"All On" mode

Depending on the vehicle, this mode includes the following driving assistance functions:

- overspeed sound alert → 242;
- driver vigilance warning → 240;
- blind spot warning → 223;
- lane departure warning → 216.

When the "All On" mode is activated: the indicator light on switch **1** lights up and the "My Safety All ON selected" message is displayed on the instrument panel to confirm activation. The driving aids that are available in the mode are activated.

"Custom" mode

From this mode **you can deactivate or reactivate** certain driving aids that are available in the "All On" mode previously configured using the "My Safety Custom" setting.

With the ignition on, **press** button **1** twice in succession to activate the "Custom" mode.

The first time you press it, the "Press again for My Safety Perso" message is displayed on the instrument panel. On the second press, the indicator light on the switch **1** goes out. The "Custom" mode is activated. The "My Safety Perso selected" message is displayed on the instrument panel.

To switch back to "All On" mode, **press once** on button **1** and the indicator light on switch **1** lights up.



Depending on the vehicle, depending on the length of time following the last time the engine was stopped, the "All On" mode is reactivated:

- when the vehicle is unlocked;
- or
- when a door is opened;
- or
- when the engine is restarted.

ADDITIONAL DRIVING AID FUNCTIONS

Configuring "My Safety Custom"

Configuration from the multimedia screen 2



Refer to the multimedia instructions for information on accessing the settings.

Configuration from the instrument panel 3

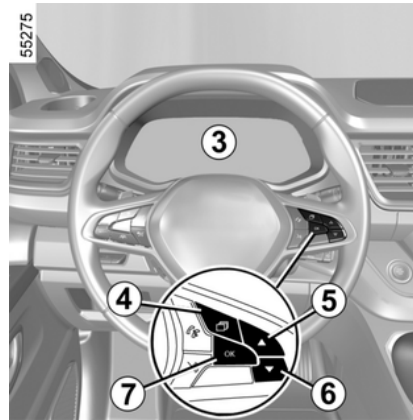

- With the vehicle stationary, press switch **4** as many times as required to reach the "Vehicle" tab;
- press the control **5** or **6** repeatedly to reach the "Settings" menu. Press switch **7** OK;
- press controls **5** or **6** repeatedly to reach the "MY SAFETY CUSTOM" menu. Press switch **7** OK;
- select the driving aids to be deactivated or activated from the "Custom" mode by repeatedly pressing control **5** or **6**. Press switch **7** OK to deactivate or activate driving aids.

Vehicle with "Overspeed" function

 In exceptional circumstances (e.g. steep gradient), the overspeed function speed may be exceeded slightly as the function does not affect the braking system.



The function does not take the place of the driver. Under no circumstances should it replace observation of speed limits nor vigilance and responsibility on the part of the driver.

ADDITIONAL DRIVING AID FUNCTIONS

53932

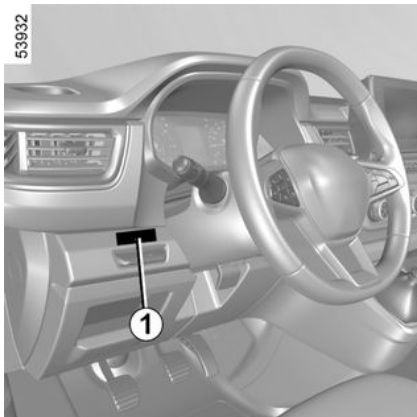

The vehicle speed may be permanently set at a fixed value depending on the vehicle or on local legislation.

To adjust the value or activate/deactivate the function, consult an approved dealer.

In the event of statutory limits (depending on the vehicle), this function may not be deactivated.

The label **1** attached to the dashboard shows the overspeed limit.

Special case: if your vehicle is fitted with the Cruise control-Speed limiter, fully pressing the accelerator pedal (beyond the point of resistance) will not enable you to exceed the overspeed function set speed → **250**.

Lane departure warning

Introduction

 You can retake control of the vehicle at any time by operating the steering wheel.

53996

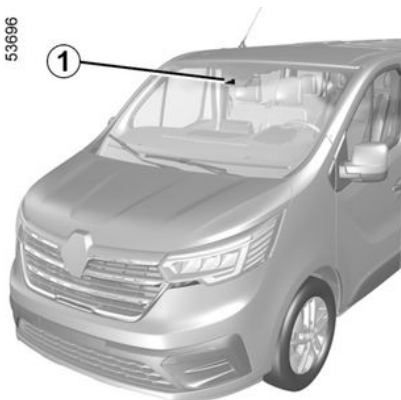

Using information from the camera **1**, the function warns the driver if the vehicle crosses a line (continuous or broken) without having activated the direction indicator lights.



This function is an additional driving aid. This function is not under any circumstances intended to replace the due care and attention of the driver, who should at all times be in control of the vehicle. **The lane departure warning function does not correct the vehicle's trajectory.**

Location of the camera **1**

Make sure the windscreen is not obscured (by dirt, mud, snow, condensation etc.).

Activation/deactivation



For safety reasons, carry out any adjustments while the vehicle is stationary.

ADDITIONAL DRIVING AID FUNCTIONS

 Then, depending on the length of time following the last time the engine was stopped, the alerts are reactivated:

- when the vehicle is unlocked;
- or
- when a door is opened;
- or
- when the engine is restarted.

Vehicles equipped with the "My Safety" button 2

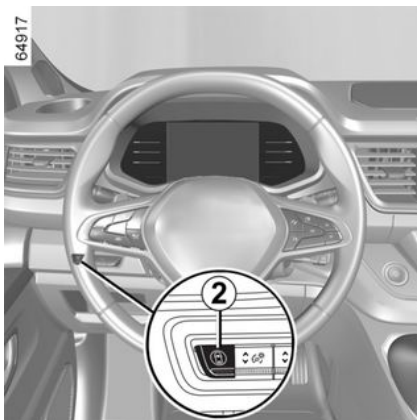

The function's deactivation and activation settings can be configured from the "Custom" mode of the "My Safety" function → 214.

If the function's deactivation has previously been configured from the "Custom" mode:

– **to deactivate the function**, press the button **2** twice. The  warning

light is displayed in white, the  warning light is displayed in yellow or,

depending on the vehicle, the  warning light is displayed in yellow on the instrument panel.

– **to reactivate the function**, press

the button **2** once. The  warning light or, depending on the vehicle, the

 warning light appears in grey on the instrument panel.

Vehicles fitted with a multimedia screen 3

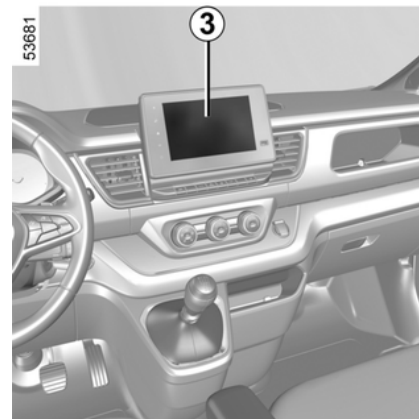

To activate or deactivate the function, refer to the multimedia instructions. Select ON or OFF.

ADDITIONAL DRIVING AID FUNCTIONS

Activating/deactivating the system from the trip computer 4

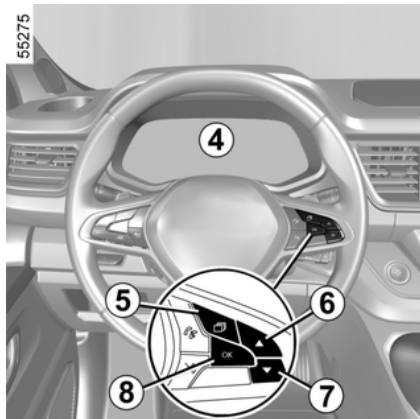

With the vehicle stationary, to deactivate/activate the alert:

- press the switch **5** as many times as required to reach the "⚙️" tab or, depending on the vehicle, the "🚗" tab;

or

- press control **5** and repeatedly press control **6** or **7** to reach the "⚙️" tab;
- depending on the vehicle, press the switch **8** OK;

- repeatedly press control **6** or **7** to reach the "🚗" menu, then press the switch **8** OK;
- repeatedly press control **6** or **7** to reach the "DRIVING AIDS" menu, then press the switch **8** OK;
- repeatedly press control **6** or **7** to reach the "Lane departure" menu, then press the switch **8** OK;
- press switch **8** OK again to activate or deactivate the alert:

- alert activated;
- alert deactivated.

When the function is deactivated, the



warning light is displayed in

white, the "🚗" warning light is displayed in yellow or, depending on the

vehicle, the "🚗" warning light is displayed in yellow on the instrument panel.

Operation

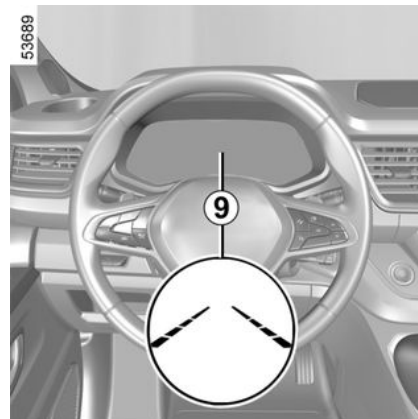

When the function is activated, de-

pending on the vehicle, the "🚗" warning light or, depending on the ve-

hicle, the "🚗" warning light and the left-hand and right-hand line indicators **9** appear in grey on the instrument panel.

The function is set to notify the driver if:

- the vehicle speed is between approximately 40 mph (65 km/h) and 105 mph (170 km/h);
- and

ADDITIONAL DRIVING AID FUNCTIONS

– the  warning light or, depending on the vehicle, the left-hand and right-hand line indicators **9** and the

 warning light appear in white on the instrument panel.

The function **triggers an alert** if the vehicle crosses a line without the direction indicators having been activated.

The function alerts the driver:

– by emitting a beep;

– the  warning light flashes in white or, depending on the vehicle, the

 warning light and the indicator **9** on the side of the breached line appear in red on the instrument panel.

Settings

Vehicles fitted with a multimedia screen.

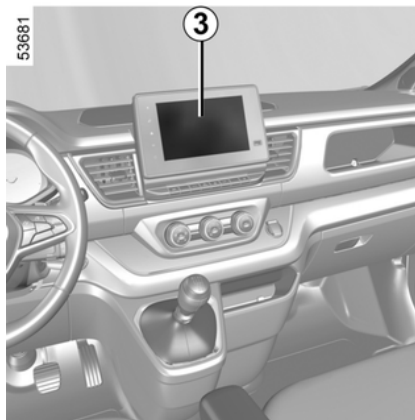

To access the function settings from the multimedia screen **3**, refer to the multimedia instructions:



- "Volume": adjust the volume of the alert;
- "Alert": adjust the line detection sensitivity level. To do this, select:
 - "Late": line detected when breached;
 - "Standard": line detected when approached;
 - "Early": line detected when near.

Please refer to the multimedia instructions for more information.

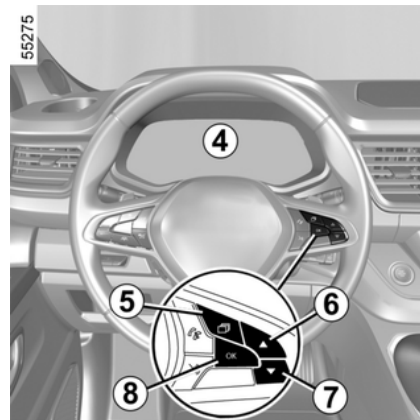
Vehicles not fitted with a multimedia screen



With the vehicle stationary, to deactivate/activate the alert:

- press the switch **5** as many times as required to reach the " " tab or, depending on the vehicle, the " " tab;
- or
- press control **5** and repeatedly press control **6** or **7** to reach the  tab;

ADDITIONAL DRIVING AID FUNCTIONS

- depending on the vehicle, press the switch **8** OK;
- repeatedly press control **6** or **7** to reach the  menu, then press the switch **8** OK;
- repeatedly press control **6** or **7** to reach the "DRIVING AIDS" menu, then press the switch **8** OK;
- press control **6** or **7** repeatedly to reach the "Lane Keep Assist sensitivity" menu, then press the switch **8** OK;
- repeatedly press control **6** or **7** to adjust the setting. Press switch **8** OK.

To adjust the sensitivity:

- repeatedly press control **6** or **7** to reach the "Lane Departure volume" or "Lane departure warning sensitivity" menu. Press switch **8** OK

To adjust the volume:

- repeatedly press control **6** or **7** to reach the "Lane departure warning volume" menu. Press switch **8** OK;
- press control **6** or **7** repeatedly to adjust the setting. Press switch **8** OK.

Function temporarily unavailable/ disabled

The function is temporarily unavailable or disabled in the following cases:

- very fast lane departure;
- driving continuously on a line;
- approximately four seconds after changing lanes;
- tight bends;
- impaired visibility;
- one of the direction indicators is activated;
- activating the hazard warning lights;
- engaging reverse gear;
- strong acceleration;
- the lane width changes;
- operation of the electronic stability control ESC;
- operation of the anti-lock braking system;
- operation of the active emergency braking system.

When the function is not available, the



warning light or, depending on the vehicle, the left-hand and right-

hand lines **8** and the  warning light appear in grey on the instrument panel.

When the front camera is obscured, the "Front camera no visibility" message is displayed on the instrument

panel. Clean the area where the sensors are located.

Automatic deactivation of the system

The system is automatically deactivated when:

- the electronic stability control (ESC) is deactivated or malfunctions;
- the anti-lock braking system is malfunctioning;
- A towbar is electrically connected to the trailer hitch socket;
- the  warning light is displayed.

When the function is deactivated, the



warning light is displayed in



white, the  warning light is displayed in yellow or, depending on the

vehicle, the  warning light is displayed in yellow on the instrument panel.

Operating faults

When the system detects an operating fault, depending on the vehicle:

ADDITIONAL DRIVING AID FUNCTIONS

- the  warning light is displayed in white, the  warning light is displayed in yellow or the  warning light is displayed in yellow on the instrument panel;
- in some cases accompanied by the message:
 - « Driving assist unavailable » ;
- or
 - "Check driving aids";
- or
 - « Check Front camera ».

In these cases, please contact an approved dealer.

ADDITIONAL DRIVING AID FUNCTIONS

Warning



This function is an additional driving aid. This function is not under any circumstances intended to replace the due care and attention of the driver, who should at all times be in control of the vehicle.

System servicing/repairs

- In the event of an impact, the camera alignment may be changed, and its operation may consequently be affected. Deactivate the function, then consult an authorised dealer.
- Any work in the area where the camera is located (repairs, replacements, windscreen modifications etc.) must be carried out by a qualified professional.

Only an authorised dealer is qualified to service the system.

In the event of system disturbance

Some conditions can disturb or damage the system's operation, such as:

- windscreen obscured (by dirt, ice, snow, condensation etc.);
- poor weather conditions (snow, rain, hail, black ice, etc.);
- poor visibility (night, fog, etc.);
- the road markings are irregular or difficult to distinguish (e.g. partially erased, excessive spacing, distorted road surface...);
- being dazzled (glaring sun, lights of vehicles travelling in the opposite direction; etc.);
- the road is narrow, winding or undulating (tight bends, etc.);
- closely following a vehicle travelling in the same lane.

Risk of false alarms or absence of warnings

ADDITIONAL DRIVING AID FUNCTIONS

Blind spot warning

Special feature



This function is an additional driving aid. This function is not under any circumstances intended to replace the due care and attention of the driver, who should at all times be in control of the vehicle.

53739

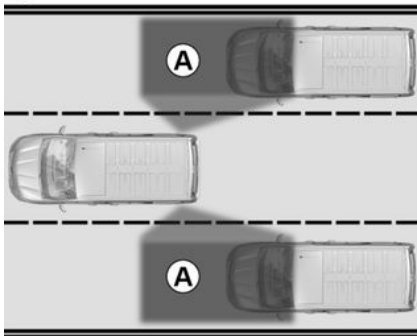

Using information from the ultrasonic sensors fitted on each side of the bumpers (zone **B**), the system notifies

the driver when another vehicle appears in the detection zone **A**.

The system is activated when the vehicle speed is between 19 mph (30 km/h) and 105 mph (170 km/h).

55556

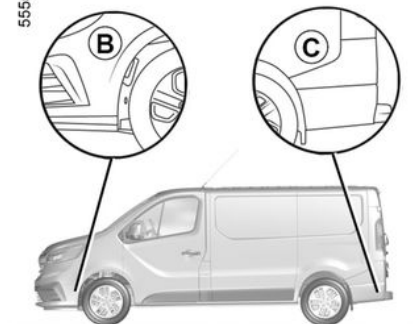

Ensure that the ultrasonic sensor zones **B** and **C** on each side of the bumpers are not obscured (by dirt, mud, snow, etc.).

If one of the ultrasonic sensors is obscured, the "Side radars no visibility" message is displayed on the instrument panel. Clean the ultrasonic sensor zones.

Activation/deactivation

Activating, deactivating alerts using the "My Safety" button **1**

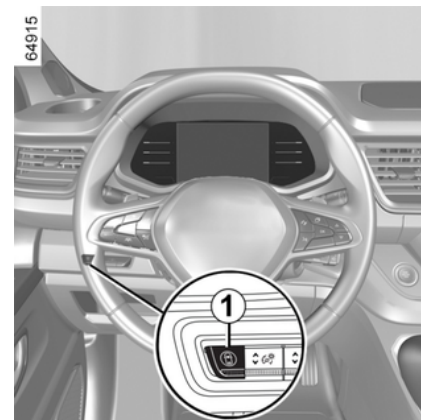

The alerts can be deactivated or activated using "Custom" mode in the "My Safety" function → 214.

If the alerts have previously been deactivated using Custom mode:

- **to deactivate the alerts**, press the button **1** twice. The indicator light on the button **1** goes out;
- **to reactivate alerts**, press the button **1** once. The indicator light on the button **1** lights up.

ADDITIONAL DRIVING AID FUNCTIONS

Activating and deactivating the alerts from the multimedia screen

2

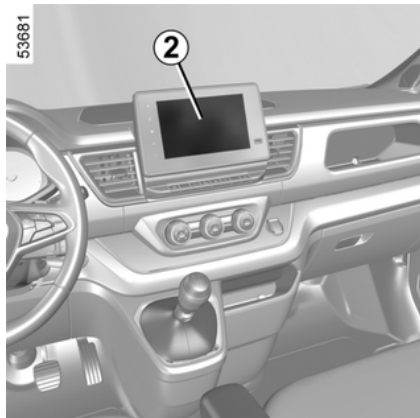





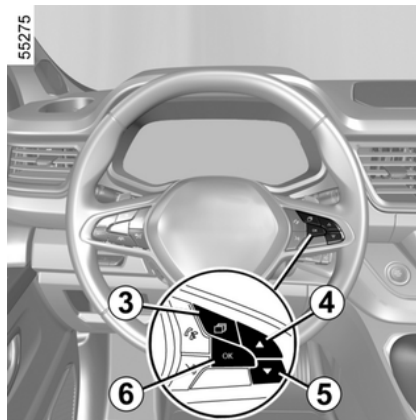

To activate or deactivate the function, refer to the multimedia instructions. Select "ON" or "OFF".

Vehicles not fitted with a multimedia screen



With the vehicle stationary, to deactivate/activate the function:

- press the switch **3** as many times as required to reach the "  " tab or, depending on the vehicle, the "  " tab;
- or
- press switch **3** and repeatedly press control **4** or **5** to reach the  tab;
- depending on the vehicle, press the switch **6** OK;

- repeatedly press control **4** or **5** to reach the  menu, then press the switch **6** OK;
- repeatedly press control **4** or **5** to reach the "DRIVING AIDS" menu, then press the switch **6** OK;
- repeatedly press control **4** or **5** to reach the "Blind spot warning" menu, then press switch **6** OK;
- press switch **6** OK again to activate or deactivate the function:
 -  function activated;
 -  function deactivated.

Warning light 6

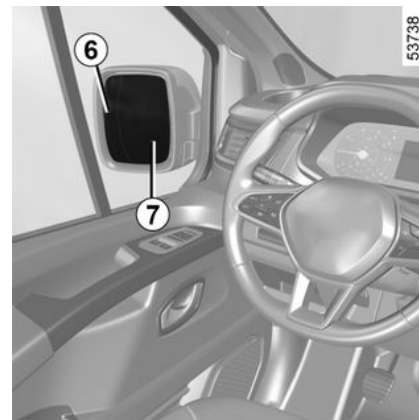

ADDITIONAL DRIVING AID FUNCTIONS

A warning light **6** is located on each door mirror **7**.

Note: clean the door mirrors **7** regularly so that the warning lights **6** remain visible.

Operation

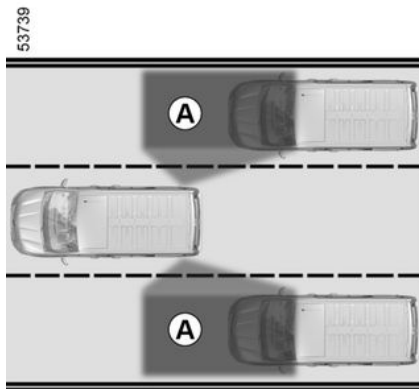

The function alerts you if your vehicle speed is between approximately 19 mph (30 km/h) and 112 mph (180 km/h) while another vehicle is in the blind spot **A** and moving in the same direction as your vehicle;

If you overtake another vehicle, the indicator light **6** will only come on if that vehicle remains for a long enough period in your vehicle's blind spot **A**.

Operating faults

If the system detects a fault, the "Check Side radars" message is displayed on the instrument panel. Consult an approved dealer.

Display **D**

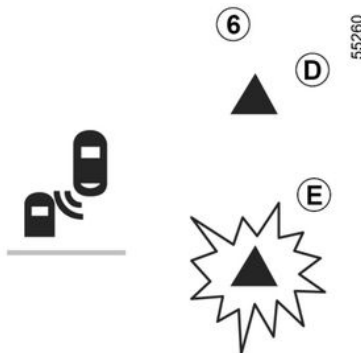

First warning: **if the direction indicator is not activated**, the warning light **6** indicates that a vehicle is detected in the blind spot **A** and/or that a vehicle is rapidly approaching from the rear in an adjacent lane.

i Due to the presence of ultrasonic sensors behind the bumper, it is advisable to entrust any operation on the bumper (repair, replacement, paintwork etc.) to a qualified professional.

Display **E**

If the direction indicator is activated, the warning light **6** flashes when the function detects a vehicle or cyclist in zone **A**.

If you deactivate the direction indicator, the function will return to the initial warning (display **D**).

Note: the alert function is based on information from the radar. In certain situations (traffic jams, etc.), it may alert any type of moving object that is in zone **A**.

Conditions for non-function

- When driving on a road with tight bends;
- in reverse.

If the vehicle is equipped with a towbar recognised by the system, the "Trailer: blind spot warning off" message is displayed on the instrument panel to in-

ADDITIONAL DRIVING AID FUNCTIONS

form you that the function is not operational. For information on the range of equipment adapted to your vehicle, we advise you to consult an approved Dealer.

3



Then, according to the length of time following the last time the engine was stopped, the function is reactivated:

- when the vehicle is unlocked;
- or
- when a door is opened;
- or
- when the engine is restarted.



- The system's detection range operates according to a standard lane width. If you are driving in wide traffic lanes, the system might not be able to detect a vehicle in the blind spot.
- In the event of very bad weather conditions (heavy rain, snow, etc.), the system may be temporarily disrupted. Remain aware of driving conditions.

There is a risk of accidents.

ADDITIONAL DRIVING AID FUNCTIONS

Warning



This function is an additional driving aid. This function is not under any circumstances intended to replace the due care and attention of the driver, who should at all times be in control of the vehicle.

The driver should always adapt their speed to the traffic conditions, regardless of the system indications.

The system should under no circumstances be taken to be an obstacle detector or an anti-collision system.

System servicing/repairs

- In the event of an impact, the alignment of the ultrasonic sensors may be altered and its operation may consequently be affected. Deactivate the function and consult an authorised dealer.
- Any work in the area where the ultrasonic sensors are located (repairs, replacements etc.) must be carried out by a qualified professional.

Only an authorised dealer is qualified to service the system.

System disturbance

Some conditions can disturb or damage the system's operation, such as:

- complex surroundings (metal bridges, tunnels, roads with barriers at the edge, etc.);
- poor weather conditions (snow, hail, black ice, etc.).

Risk of false alarms or absence of warnings

In the event of the system behaving abnormally, deactivate it and contact an authorised dealer.

ADDITIONAL DRIVING AID FUNCTIONS



Limitation of the system operation

- The ultrasonic detection zones should be kept clean and free of any modifications in order to ensure the proper operation of the system.
- Small objects moving close to the vehicle (motorcycles, bicycles, pedestrians, etc.) may not be recognised by the system.
- When turning into a bend, the ultrasonic sensors may temporarily cease to detect vehicles in adjacent lanes.
- The function may warn you late when two other vehicles are approaching from the rear, side by side in the adjacent lanes (driving on a 3-lane road) and at a much higher speed than your vehicle.
- The system may not provide a warning when the other vehicles are travelling at a significantly different speed.
- If the vehicle is being overtaken by a long vehicle (e.g. heavy goods vehicle overtaking at a similar speed to the vehicle) the system may interrupt the warning before the end of the manoeuvre.
- The vehicle is travelling on a winding road.

Deactivating the function

You must deactivate the function if:

- the radar area has been damaged (rear bumper);
- the vehicle is fitted with a towbar that is not recognised by the system.

ADDITIONAL DRIVING AID FUNCTIONS

Safe distance warning



This function is an additional driving aid. This function is not under any circumstances intended to replace the due care and attention of the driver, who should at all times be in control of the vehicle.

55185

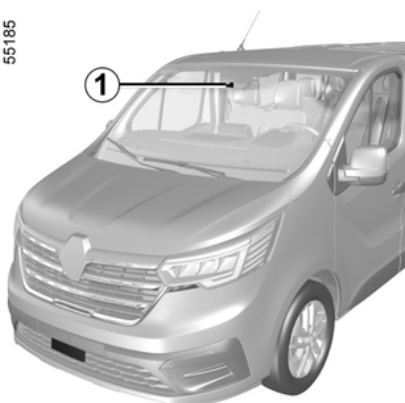

Using the information from the camera **1**, this function informs the driver of the time interval between their vehicle and the vehicle in front so that a safe

stopping distance between the two vehicles can be maintained.

The function is activated when the vehicle speed is between approximately 19 and 105 mph (30 and 170 km/h), depending on the vehicle.

Location of the camera **1**

Make sure the windscreen is not obscured (by dirt, mud, snow, condensation etc.).

Activating/deactivating the function

Vehicles fitted with a multimedia screen **2**

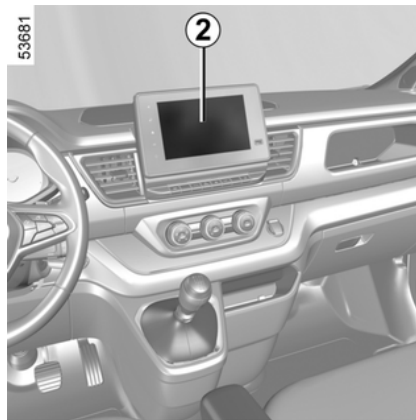

To activate or deactivate the function, refer to the multimedia instructions.



From the "Vehicle" mode on your multimedia screen **2**, press the "Driving aids" menu.

Activate or deactivate the "Safe distance" function.

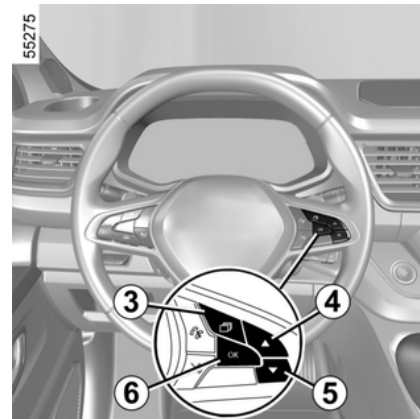



Vehicles not fitted with a multimedia screen



With the vehicle stationary, to deactivate/activate the alert:

- press the switch **3** as many times as required to reach the "  " tab or, depending on the vehicle, the "  " tab;
- or

ADDITIONAL DRIVING AID FUNCTIONS

- press switch **3** and repeatedly press control **4** or **5** to reach the  tab;
- depending on the vehicle, press the switch **6** OK;
- repeatedly press control **4** or **5** to reach the  menu, then press the switch **6** OK;
- repeatedly press control **4** or **5** to reach the "DRIVING AIDS" menu, then press the switch **6** OK;
- repeatedly press control **4** or **5** to reach the "Distance warning" menu, then press the switch **6** OK;
- press switch **6** OK again to activate or deactivate the warning:
 -  alert activated;
 -  alert deactivated.

 Each time the vehicle is started, the function continues the mode saved the last time the engine was stopped.

Operation



The measurement is displayed for information: the system does not carry out any action on the

vehicle.

This function is not designed for use in urban conditions or for a dynamic driving style (sudden cornering, acceleration, braking, etc.), but rather for stable driving conditions.

The function does not interact with the braking system.

The camera should be kept clean and free of any modifications in order to ensure the proper operation of the system.

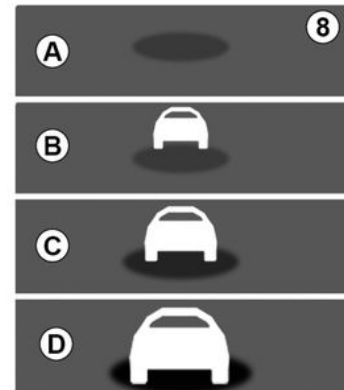

39301

With the function activated, the **8** indicator is displayed on the instrument panel and informs the driver of the distance between their vehicle and the vehicle in front.

A (grey): function not operational.

(green): no vehicle detected.

B (green): the time interval is greater than or equal to around two seconds (distance between the two vehicles adapted to your speed).

C (yellow): the time interval is between approximately one and two seconds (insufficient distance between the two vehicles).

D (red): the time interval is less than or equal to approximately one second

ADDITIONAL DRIVING AID FUNCTIONS

(very insufficient distance between the two vehicles).

If the interval between the two vehicles is less than around 0.5 seconds, the indicator light **B** on display **D** will flash in red on the instrument panel.

Under certain conditions, the time interval may not be displayed:

- while cornering;
- when changing lane;
- if the vehicle in front is sufficiently far or outside the range of the camera.

ADDITIONAL DRIVING AID FUNCTIONS

Warning



This function is an additional driving aid. This function is not under any circumstances intended to replace the due care and attention of the driver, who should at all times be in control of the vehicle.

System servicing/repairs

- In the event of an impact, the camera alignment may be changed, and its operation may consequently be affected. Deactivate the function and consult an authorised dealer.
- Any work in the area where the radar and/or camera is located (repairs, replacements, windscreen or bumper modifications, etc.) must be carried out by a qualified professional.

Only an authorised dealer is qualified to service the system.

In the event of system disturbance

- a complex environment (metal bridge, tunnel, etc.);
- poor weather conditions (snow, hail, black ice, etc.);
- poor visibility (night, fog, etc.);
- poor contrast between the vehicle preceding it and the surrounding area (e.g. white vehicle in a snowy area, etc.);
- being dazzled (glaring sun, lights of vehicles travelling in the opposite direction; etc.);
- the road is narrow, winding and undulating (tight bends etc.)

Risk of erroneous false alarms.

ADDITIONAL DRIVING AID FUNCTIONS

Active emergency braking

55185

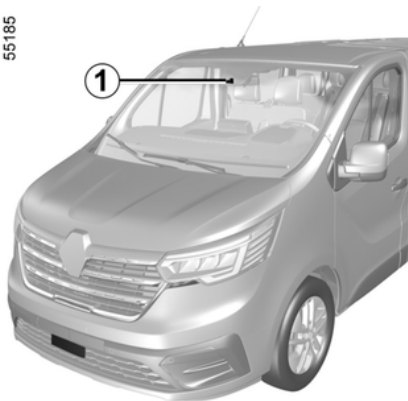

The system uses information from the camera **1** to determine how far your vehicle is:

– from the vehicle ahead in the same lane;

or

– from any oncoming vehicles in the context of a manoeuvre to change direction;

or

– from vehicles passing perpendicularly.

or

– stationary vehicles;

or

– surrounding pedestrians and cyclists.

The system informs the driver if there is a risk of head-on collision to enable appropriate emergency manoeuvres (pressing the brake pedal and/or turning the steering wheel).

Depending on the reactivity of the driver, the system can assist with braking in order to limit damage or prevent a collision.

The system is otherwise inactive and does not trigger an alert.



This function is an additional driving aid. This function is not under any circumstances intended to replace the due care and attention of the driver, who should at all times be in control of the vehicle.



This system can apply maximum braking to the vehicle until it is completely stationary if necessary.

For safety reasons, always wear your seat belt when travelling in your vehicle and make sure that it is loaded so that no items can be thrown forward and hit the occupants.

Location of the camera **1**

Make sure the windscreen is not obscured (by dirt, mud, snow, condensation etc.).

Operation

When driving, if there is a risk of collision, the system:

– **alerts you of a collision risk:** the "Obstacle detected" message appears on the instrument panel accompanied by a beep.

Note: if the driver presses the brake pedal and the system still detects a risk of collision, the braking force may be increased if it is not sufficient to prevent the collision.

– **braking may be triggered:** if the driver does not react to the alert and

ADDITIONAL DRIVING AID FUNCTIONS

the collision becomes imminent, the

red  warning light and the "Brake" message are displayed on the instrument panel accompanied by a beep.

Note:

- if the driver uses the vehicle controls (steering wheel, pedals, etc.) the system may delay its reaction or not activate;
- if active emergency braking has caused the vehicle to stop, the vehicle is kept stationary for a short time. Beyond this time limit, the driver must keep the vehicle stationary by holding their foot on the brake pedal;
- after the system activates braking, the "Advanced safety activated" message will be displayed.



In the event of an emergency manoeuvre, you can stop the braking at any moment by:

- tapping the accelerator pedal;
- or
- turning the steering wheel as a collision avoidance manoeuvre.

Vehicle detection

Detection of vehicles travelling in the same lane

The risk of a collision with the vehicle in front of you in the same lane is detected by the system when:

- your vehicle is travelling at a speed between approximately 5 mph (8 km/h) and 112 mph (180 km/h).

Detection of oncoming vehicles in the context of a manoeuvre to change direction

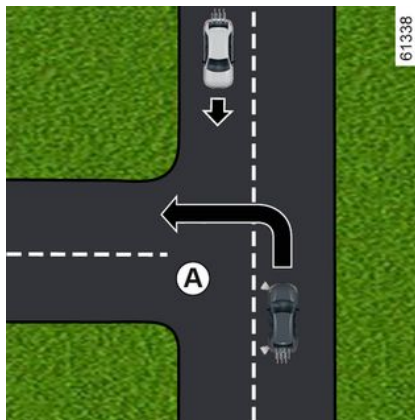

When you wish to change direction (e.g. **A**), oncoming vehicles are detected by the system when:

- your vehicle is travelling at a speed between approximately 5 mph (8 km/h) to 12 mph (20 km/h);
- you have activated the direction indicator light.

Detection of vehicles crossing the lane perpendicularly

Vehicles crossing the lane perpendicularly are detected by the system when:

- your vehicle is travelling at a speed between approximately 12 mph (20 km/h) and 37 mph (60 km/h).

Detection of stationary vehicles

Stationary vehicles are detected by the system when:

- your vehicle is travelling at a speed between approximately 4 mph (7 km/h) and 50 mph (80 km/h).

Detection of pedestrians and cyclists

Detection of pedestrians and cyclists in the same lane

The system detects pedestrians and cyclists when:

- your vehicle is travelling at a speed between approximately 5 mph (8 km/h) and 53 mph (85 km/h).

ADDITIONAL DRIVING AID FUNCTIONS

Detection of pedestrians and cyclists when changing direction

The system detects pedestrians and cyclists when:

- your vehicle is travelling at a speed between approximately 5 mph (8 km/h) to 12 mph (20 km/h);

Activation/deactivation

i Then, according to the length of time following the last time the engine was stopped, the function is reactivated:

- when the vehicle is unlocked;
- or
- when a door is opened;
- or
- when the engine is restarted.

Activating, deactivating the system from the multimedia screen 2

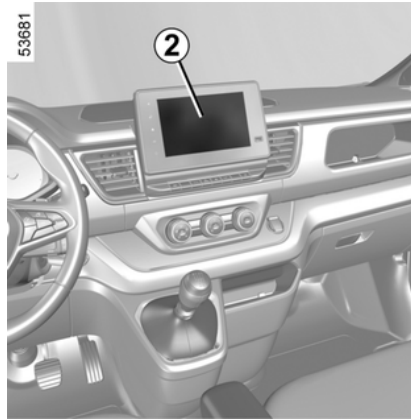



To activate or deactivate the function, please refer to the multimedia instructions.

Select ON or OFF.

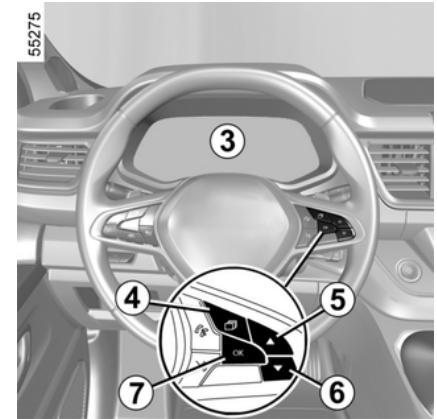
Activating/deactivating the system from the trip computer 3



With the vehicle stationary, to deactivate/activate the function:

- press the switch **4** as many times as required to reach the "  " tab or, depending on the vehicle, the "  " tab;
- or
- press switch **4** and repeatedly press control **5** or **6** to reach the  tab;
- depending on the vehicle, press the switch **7** OK;

ADDITIONAL DRIVING AID FUNCTIONS

- repeatedly press control **5** or **6** to reach the  menu, then press the switch **7** OK;
- repeatedly press control **5** or **6** to reach the "DRIVING AIDS" menu, then press the switch **7** OK;
- repeatedly press control **5** or **6** to reach the "Active braking" menu, then press switch **7** OK;

Press switch **7** OK again to activate or deactivate the function:

function activated;

function deactivated.

Upon deactivation of the system, the

 warning light comes on or, de-

pending on the vehicle, the  warning light comes on in yellow on the instrument panel.

When the system is activated, the warning light disappears.

Settings



For safety reasons, carry out any adjustments while the vehicle is stationary.

Adjusting settings from the multimedia screen **2**

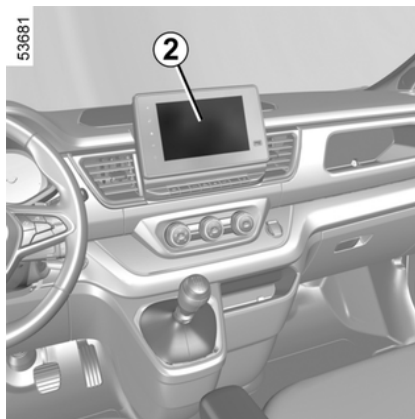

With the vehicle stationary, to access the function settings from the multimedia screen **2**; refer to the multimedia instructions:

- "Alert": adjust the sensitivity level. To do this, select:
 - "Late";



- "Standard";
- "Early".

Please refer to the multimedia instructions for more information.

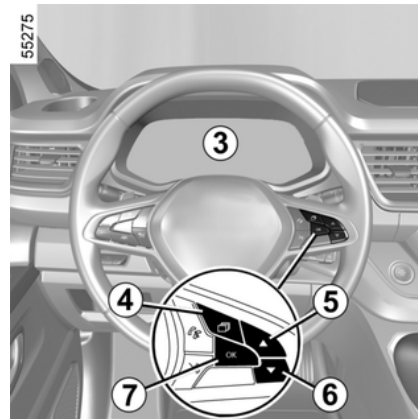

Adjusting settings from the instrument panel **3**



With the vehicle stationary, to deactivate/activate the function:

- press the switch **4** as many times as required to reach the "" tab or, depending on the vehicle, the "" tab;
- or

ADDITIONAL DRIVING AID FUNCTIONS

- press switch **4** and repeatedly press control **5** or **6** to reach the  tab;
- depending on the vehicle, press the switch **7** OK;
- repeatedly press control **5** or **6** to reach the  menu, then press the switch **7** OK;
- repeatedly press control **5** or **6** to reach the "DRIVING AIDS" menu, then press the switch **7** OK;
- repeatedly press control **5** or **6** to reach the "Active braking sensitivity" menu, then press switch **7** OK;
- press control **5** or **6** repeatedly to adjust the setting. Press switch **7** OK.

Temporarily not available

If the system detects a temporary fault

the  warning light illuminates, or

depending on the vehicle, the  warning light illuminates in yellow on the instrument panel.

The possible causes are:

- the system is temporarily blinded (glare from the sun, dipped beam headlights, bad weather conditions etc.). The system will be operational

again when visibility conditions are better;

- the system is temporarily interrupted (e.g. the windscreen or the front or rear bumper is obscured by dirt, mud, snow, condensation, etc.). In this case, park the vehicle and switch off the engine. Clean the windscreen and front bumper. When you next start the engine, the warning light and the message go out.

If this is not the case, this may arise from another cause; contact an Approved Dealer.

Operating faults

If the function detects an operating

fault, the  warning light or, de-

pending on the vehicle, the  warning light appears on the instrument panel accompanied by the "Check Front camera" or "Check camera" message.

Consult an approved dealer.

ADDITIONAL DRIVING AID FUNCTIONS

Warning



Active emergency braking

This function is an additional driving aid. This function is not under any circumstances intended to replace the due care and attention of the driver, who should at all times be in control of the vehicle. The triggering of this function may be delayed or prevented when the system detects clear signs of control of the vehicle by the driver (action on the steering wheel, pedals etc.).

The system cannot be activated:

- when the gearbox lever is in neutral or the clutch pedal has been depressed during approximately ten seconds;
- when the parking brake is activated;
- when the Electronic Stability Program (ESC) has started.

System servicing/repairs

- In the event of an impact, the camera alignment may be changed and its operation may consequently be affected. Deactivate the function and consult an authorised dealer.
- Any work in the area where the camera is located (repairs, replacements, windscreen modifications etc.) must be carried out by a qualified professional.

Only an authorised dealer is qualified to service the system.

System disturbance

Some conditions can disrupt or damage the system operation, for example:

- poor weather conditions (snow, hail, black ice, etc.);
- poor visibility (night, fog, etc.);
- poor contrast between an object (vehicle, etc.) and the surrounding area (e.g. white vehicle in snowy conditions, etc.);
- being dazzled (glaring sun, lights of vehicles travelling in the opposite direction; etc.);
- windscreen obscured (by dirt, ice, snow, condensation etc.);
- ...

In these conditions, the system may not react, may warn the driver or may brake inadvertently.

ADDITIONAL DRIVING AID FUNCTIONS



Limitation of the system operation

- Each time the vehicle is started, the system carries out a calibration according to the vehicle surroundings and may be inactive for a length of time between approximately two to five minutes.
- A vehicle travelling in the opposite direction will not trigger any alert or any action on the system operation.
- The camera should be kept clean and free of any modifications in order to ensure the proper operation of the system.
- The system cannot respond to small vehicles such as motorbikes or bicycles as effectively as to other vehicles;
- The system may not operate properly when the road surface is slippery (rain, snow, black ice, etc.);
- ...

In these conditions, the system may not react, may warn the driver or may brake inadvertently.

Deactivating the function

You must deactivate the function if:

- the camera area has been damaged (e.g. on the inside or outside of the windscreen);
- the vehicle is being towed (breakdowns);
- the windscreen is cracked or distorted (do not carry out windscreen repairs in this area; have it changed by an approved dealer);
- you are not driving on a paved road.

In the event of the system behaving abnormally, deactivate it and consult an authorised dealer.

Halting the function

You can halt the active emergency braking function at any time by tapping the accelerator pedal or by turning the steering wheel in an avoidance manoeuvre.

ADDITIONAL DRIVING AID FUNCTIONS

Driver vigilance warning

The driver vigilance warning is a function that analyses the behaviour of the driver (driving style, vehicle steering, etc.) and alerts them if there is a risk of falling asleep.

It takes into account indicators such as:

- steering wheel movement;
- driver actions on other systems (indicators, brake pedal, etc.).



This function is an additional driving aid in case of risk of fatigue. This function does not take the place of the driver.

Under no circumstances should this function replace the driver's care or responsibility whilst driving.

Operation

The function is set to notify the driver if:

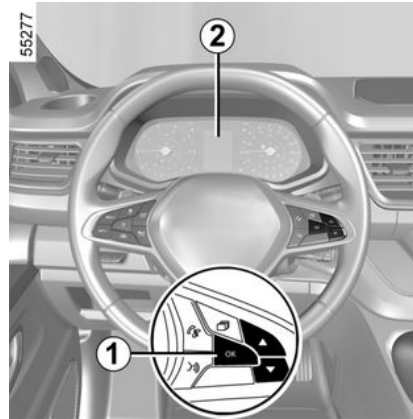

- a few minutes have elapsed since the vehicle last stopped;
- the vehicle speed is greater than approximately 43 mph (70 km/h).

If there is a risk of fatigue or impaired attention, the "Driver vigilance warning: take a break" message is displayed on the instrument panel **2**, accompanied by a beep.

Press switch **1** OK to clear the alert. It is advisable to stop as soon as possible for a break.

After deleting the message, the system continues vigilance monitoring and issues a new warning if necessary.



The driver vigilance warning constantly monitors the driver's attention and can provide several warnings per journey.

The system resets every time the engine is started.

Activation/deactivation

Alerts can be deactivated or activated from the "Custom" mode of the "My Safety" function

Note: when the alerts are deactivated, the system continues to assess the driver's state of fatigue.

ADDITIONAL DRIVING AID FUNCTIONS

i Then, depending on the length of time following the last time the engine was stopped, the alerts are reactivated:

- when the vehicle is unlocked;
- or
- when a door is opened;
- or
- when the engine is restarted.

i When the alerts are deactivated, the system continues to assess the driver's state of fatigue.

Activating, deactivating alerts using the "My Safety" button **1**

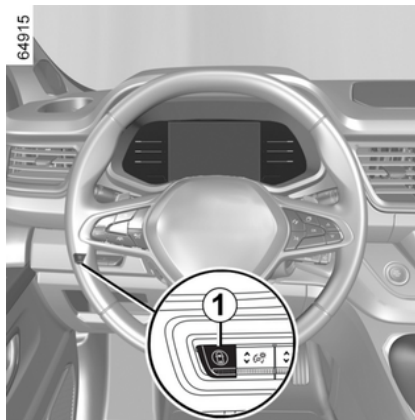

The alerts can be deactivated or activated using "Custom" mode in the "My Safety" function → 214.

If the alerts have previously been deactivated using Custom mode:

- **to deactivate the alerts**, press the button **1** twice. The indicator light on the button **1** goes out;
- **to reactivate alerts**, press the button **1** once. The indicator light on the button **1** lights up.

Activating and deactivating the alerts from the multimedia screen **2**

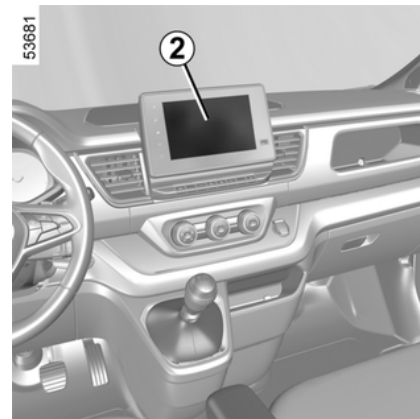

To activate or deactivate the alerts, please refer to the multimedia instructions.

Select ON or OFF.

ADDITIONAL DRIVING AID FUNCTIONS

Activating/deactivating the alerts from the trip computer 3

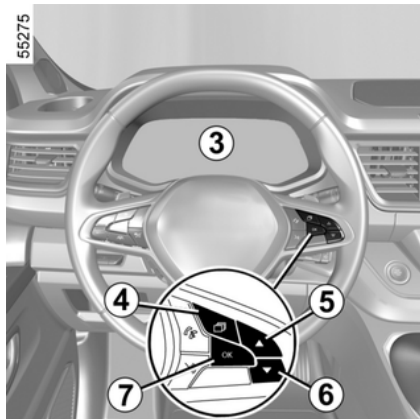

With the vehicle stationary, to deactivate/activate the alert:

- press the switch **4** as many times as required to reach the "⚙️" tab or, depending on the vehicle, the "🚗" tab;
- or
- press switch **4** and repeatedly press control **5** or **6** to reach the "⚙️" tab;
- depending on the vehicle, press the switch **7** OK;

- repeatedly press control **5** or **6** to reach the "🚗" menu, then press the switch **7** OK;
- repeatedly press control **5** or **6** to reach the "DRIVING AIDS" menu, then press the switch **7** OK;
- press control **5** or **6** repeatedly to reach the "Driver vigilance warning" menu, then press the switch **7** OK;
- press switch **7** OK again to activate or deactivate the warning:
 - alert activated;
 - alert deactivated.

Limitations of system operation

Some conditions can disrupt or damage the operation of the system, for example:

- certain driving styles (incorrect driving etc.) ;
- driving on a road in poor condition;
- strong side wind;
- the clock is wrongly configured (depending on vehicle) ➔ **150**;
- winding roads;
- trailer traction.

Operating faults

If the system detects a fault, the "👁️" warning light appears accompanied by the "Check Fatigue Warning System" message on the instrument panel **1**.

Have the system checked by an authorised dealer.

Detection of road signs

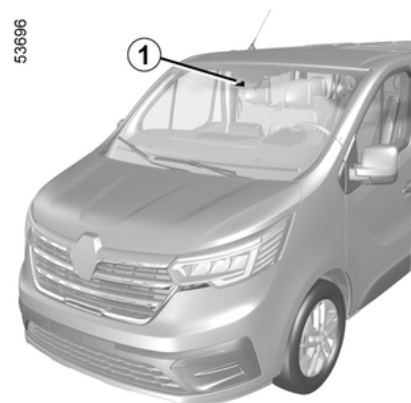

The system displays speed limits on the instrument panel according to road signs detected on the side of the road.

It mainly uses information taken from the camera **1** attached to the windshield behind the rear view mirror.

ADDITIONAL DRIVING AID FUNCTIONS

Depending on the country, the system also uses information from a map subscription to interpret certain signs (town entrance, etc.). The sign displayed on the instrument panel changes when a road sign is detected by the system.

Once the speed limiter or the cruise control is activated, you can adapt the limited speed setpoint to the speed limit displayed on the instrument panel by the system (➔ 250 and ➔ 254).

If the detected speed limit is exceeded, the road sign displayed on the instrument panel is modified to inform the driver.

Location of the camera 1

Make sure the windscreen is not obscured (by dirt, mud, snow, condensation etc.).

Special features

For vehicles with a map subscription:

– if the vehicle is travelling in a country where the speed units differ from those of the vehicle, the system displays the speed limit sign in the unit of the country, alongside the speed limit converted to the unit used by the vehicle's instrument panel;

– for countries where the speed limit is reduced during rainy weather on some types of roads, the system may alter the detected speed limit after a few seconds of the windscreen wipers being activated.

On vehicles not fitted with a navigation system: when driving in a country where the speed units differ from that of your vehicle, you can manually select the relevant speed unit on the instrument panel (e.g. change from miles to kilometres) in order to obtain the appropriate information ➔ 145.

Note:

The system does not take into account exceptional speed limit measures, such as peak pollution days.



Road sign detection is associated with a map subscription.

If there is no subscription, the system will be limited to taking into account the speed limit signs when they are detected by the camera.

The system will no longer take into account information related to the maps. The speed limit availability may be affected.

Depending on the equipment, it is necessary to update the maps regularly. If the maps are not updated, system performance will be impaired.

To manage the subscription, please refer to the multimedia instructions.

ADDITIONAL DRIVING AID FUNCTIONS

Operation

Warning lights

3



The function displays the following warning lights:

2 Speed limit signs and additional speed limit signs (speed on exit ramp with arrow, speed with a caravan, speed limit with length of application, etc.)

3 Additional road signs (start of no overtaking zone).

If the detected speed limit is exceeded, a circle flashes around the road sign (warning light **2**) accompanied, depending on the vehicle, by a beep emitted for a few seconds to warn you.

It remains illuminated on the instrument panel as long as the vehicle speed is exceeding the speed limit.

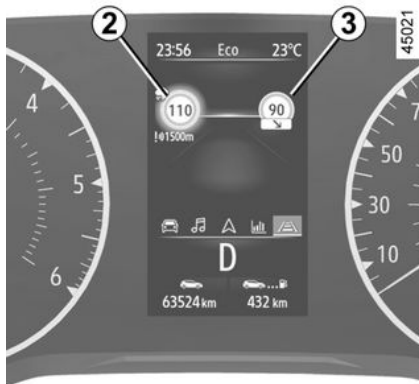

Map subscription

Road sign detection is associated with a map subscription. Depending on the equipment, it is necessary to update the maps regularly.

If the maps are not updated, system performance will be impaired (incorrect speed limit, etc.)

Note: if there is no map for a country, a message will appear on the multimedia screen to inform of this and suggest downloading the map information relating to the country.

To manage the subscription, please refer to the multimedia instructions.

If there is no subscription, the system will be limited to taking into account the speed limit signs when they are detected by the camera.

The system will no longer take into account information related to the maps. The speed limit availability may be affected.

ADDITIONAL DRIVING AID FUNCTIONS

Activation/deactivation



For safety reasons, carry out any adjustments while the vehicle is stationary.



Depending on the length of time since the engine was last stopped, the sound alert is reactivated:

- when the vehicle is unlocked;
- or
- when a door is opened;
- or
- when the engine is restarted.

Activating, deactivating the overspeed sound alert using the "My Safety" button 1

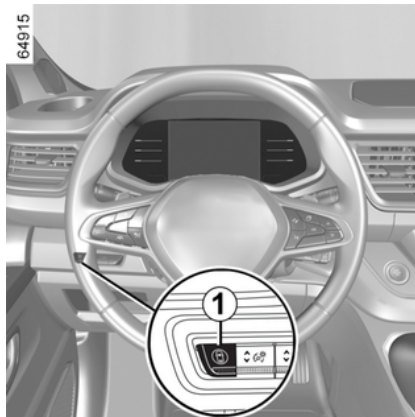

The sound alert can be deactivated or activated using "Custom" mode in the "My Safety" function → 214.

If the sound alert has previously been deactivated using "Custom" mode:

- **to deactivate the sound alert**, press the button **1** twice. The indicator light on the button **1** goes out;
- **to reactivate the sound alert**, press the button **1** once. The indicator light on the button **1** lights up.

Activating, deactivating the overspeed sound alert from the multimedia screen 2

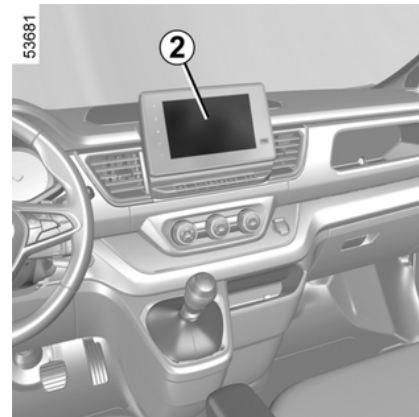

To activate or deactivate the sound alert, please refer to the multimedia instructions.

Select ON or OFF.

ADDITIONAL DRIVING AID FUNCTIONS

Activating/deactivating the over-speed sound alert from the trip computer 3

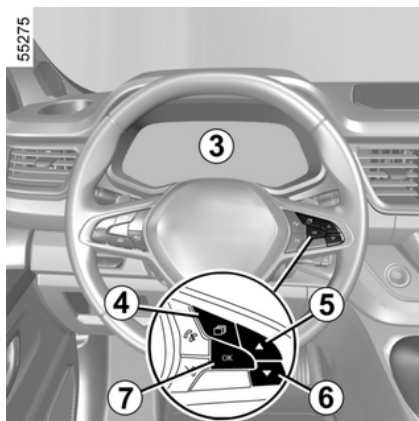

With the vehicle stationary, to deactivate/activate the alert:

- press the switch **4** as many times as required to reach the "⚙️" tab or, depending on the vehicle, the "🚗" tab;
- or
- press switch **4** and repeatedly press control **5** or **6** to reach the "⚙️" tab;
- depending on the vehicle, press the switch **7** OK;

- repeatedly press control **5** or **6** to reach the "🚗" menu, then press the switch **7** OK;
- repeatedly press control **5** or **6** to reach the "DRIVING AIDS" menu, then press the switch **7** OK;
- repeatedly press control **5** or **6** to reach the "Detection of road signs" menu, then press switch **7** OK;
- press switch **7** OK again to activate or deactivate the warning:
 - alert activated;
 - alert deactivated.

Variation of the limited speed or cruising speed

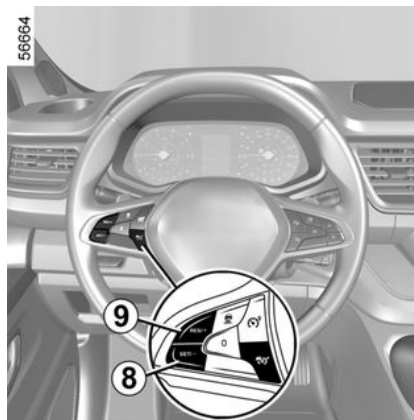

To adapt the speed limiter, cruise control or adaptive cruise control setpoint to detected speed limits, press switch **8** (SET/-) or **9** (RES/+).

Temporary unavailability

If the system is unavailable for reasons related to the camera or map data, the



symbol or, depending on the vehicle, the



symbol is displayed on the instrument panel. If there is still a problem, contact an approved dealer.

The system cannot detect the speed limit if:

- the windscreen is not clean;
- the camera is blinded by the sun;
- there is insufficient visibility (fog, etc.);
- the signs are not legible (snow, etc.) or are hidden (by another vehicle or by trees);
- the information taken from the map is not up to date.

Note: when the front camera is obscured, the "Front camera no visibility" message is displayed on the instrument panel. Clean the windscreen area in front of the camera.

ADDITIONAL DRIVING AID FUNCTIONS

Operating faults

When the system detects an operating fault, the



or, depending on the vehicle,



symbol is displayed on the instrument panel.

In some cases, they are accompanied by the following message:

– « Driving assist unavailable »

or

– « Check Front camera »

or

– « Check Driving assist »

Consult an approved dealer.

ADDITIONAL DRIVING AID FUNCTIONS

Warning



This function is an additional driving aid. This function is not under any circumstances intended to replace the due care and attention of the driver, who should at all times be in control of the vehicle.

The driver should always adapt their speed to the traffic conditions, regardless of the system indications.

The system detects speed limit signs and does not detect other signs (e.g. entry to/exit from urban areas, etc.).

The system may not detect all speed limit signs or may interpret them incorrectly.

The driver must not ignore road signs undetected by the system and should give priority to complying with the actual road signs and the highway code.

In the event of poor visibility (fog, snow, frost, etc.), it is possible that the system may not indicate the correct speed to the driver.

The driver should always adapt their speed to the traffic conditions, regardless of the system indications.

FAST IDLE SPEED

Operation



Press the switch **1**, then the function will be activated after a few seconds.



Modifying fast idle speed

To increase or reduce the speed, contact an approved dealer.

Switching off the function

The function is interrupted when:

- you press the clutch pedal and/or accelerator pedal;
- the vehicle speed is above 0 mph (0 km/h);

- the **STOP** warning light appears on the instrument panel;
- the  warning light appears on the instrument panel;
- warning light  comes on the instrument panel.

 Special feature of the Stop and Start function: activating the "Fast Idle Speed" function prevents the engine from going into standby ➔ **184**.

SPEED LIMITER

Introduction

i You can link the speed limiter to the "Road sign detection" function. → 242.

The speed limiter function helps you stay within the driving speed limit that you choose, known as the **limit speed**.

The speed limiter is linked with the "Hill Descent Control" function, enabling use of the braking system to optimise downhill speed limitation.

Controls

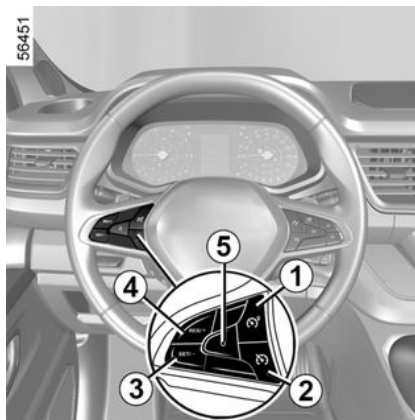

1. Speed limiter On/Off switch.
2. Cruise control On/Off switch.
3. Switch to activate and decrease the limit speed (SET/-).
4. Switch to activate and increase the limit speed or to set the stored limit speed (RES/+).
5. Puts the function on standby and stores the limited speed (0).

i **Temporarily not available**
The system controls acceleration and deceleration of your vehicle using the engine and braking system. The system activates the brakes in order to maintain the set speed, the system applies limited braking. In the event of a steep descent, for example in a mountainous area, you must select a lower gear to benefit from engine braking.
To reduce the load imposed on the braking system and to prevent the brakes from overheating, the speed limiter function may be temporarily interrupted and the "Check Speed Limiter" message may appear. The message disappears when the function becomes available again.
If the message remains, contact an approved dealer.

SPEED LIMITER

Driving

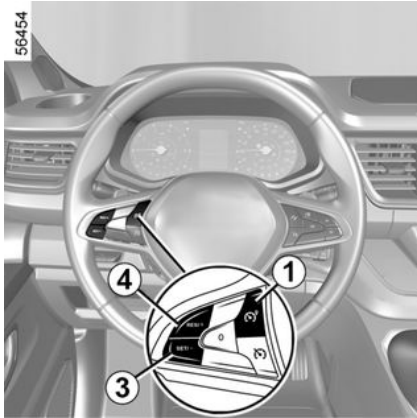



When a limit speed has been set but not yet reached, driving is similar to driving a vehicle without the speed limiter function.

Once you have reached the stored speed, no effort on the accelerator pedal will allow you to exceed the programmed speed except in an emergency (refer to information on "Exceeding the limit speed").

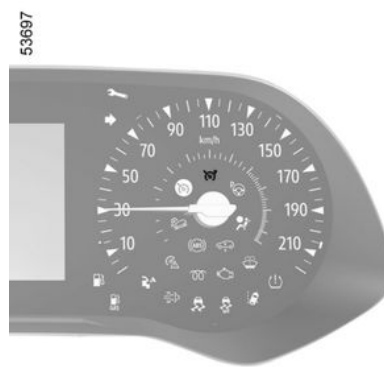

Switching on



Press switch **1** until the  warning light is displayed on the instrument

panel. The  or  warning light appears in grey on the instrument panel. The "Speed limiter OK SET to activate" message appears on the instrument panel accompanied by dashes to indicate that the speed limiter function is in operation and waiting to store a limit speed.

To store the current speed, press switch **4** (SET/-) or **5** (SET/+): the limit speed replaces the dashes and, de-

pending on the vehicle, the  or  warning light appears in white.

SPEED LIMITER

The minimum stored speed is 19 mph (30 km/h). The function can be activated from 0 mph (0 km/h).

The minimum stored speed is 19 mph (30 km/h).

Note: the "Speed limiter" function can be activated between 0 mph and 112 mph (0 km/h and 180 km/h).

Varying the limit speed

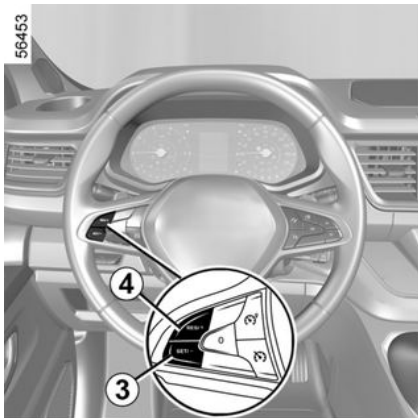

The limit speed may be changed by pressing repeatedly or holding down:

- switch **4** (RES/+) to increase the speed;
- switch **3** (SET/-) to reduce speed.

Exceeding the limit speed



You must keep your feet near the pedals to be ready to react in an emergency.



If the speed limiter is not available (after several attempts to activate), contact an approved dealer.

It is possible to exceed the limit speed at any moment. To do this, press the accelerator pedal **firmly down** beyond the point of resistance.

While the speed is being exceeded, the speed limiter flashes red on the instrument panel. Then, release the accelerator pedal: the speed limiter function will return as soon as you reach a speed lower than the memorised speed.

Putting the function on standby

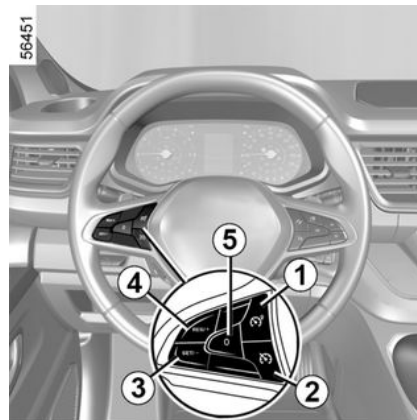

The speed limiter function is suspended when you press switch **5** (0). The limit speed is stored and displayed in grey on the instrument panel.

Recalling the limit speed

If a speed has been stored, it can be recalled by pressing the switch **4**.

SPEED LIMITER

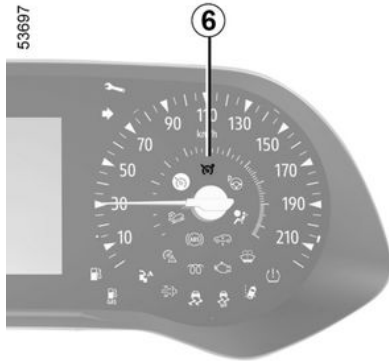

– when you press the **2** switch. In this case the cruise control is selected and there is no stored speed.

The warning light  disappears from the instrument panel to confirm that the function is no longer active.



When the speed limiter is set to standby, pressing switch **3** reactivates the function without taking into account the memorised speed: it is the speed at which the vehicle is moving that is taken into account.

Switching off the function

The speed limiter function is interrupted:

– when you press the **1** switch. In this case, the speed is no longer stored;

CRUISE CONTROL

Introduction



This function is an additional driving aid.

It can under no circumstances replace the driver's responsibility to respect speed limits or to be vigilant. The driver must always be in control of the vehicle.

Cruise control must not be used in heavy traffic, on winding or slippery roads (black ice, aquaplaning, gravel) and during bad weather (fog, rain, side winds etc.).

There is a risk of accidents.

The cruise control function helps you to maintain your driving speed at a speed that you choose, called the **crusing speed**.

This crusing speed can be set at any speed above 19 mph (30 km/h).

The cruise control function is linked with the "Hill Descent Control" function, enabling use of the braking system to optimise downhill cruise control.

Controls

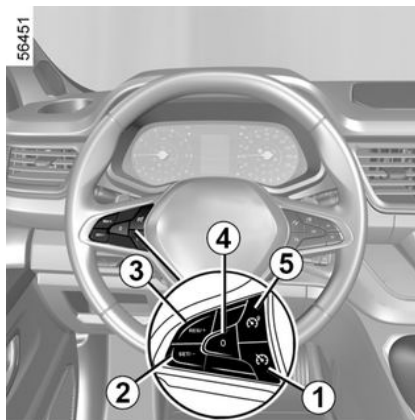

1. Cruise control On/Off switch.
2. Switch to activate and decrease cruising speed (SET/-).
3. Switch to activate and increase cruising speed or to recall the memorised cruising speed (RES/+).
4. Put the function on standby (with cruising speed stored) (0).
5. Speed limiter On/Off switch.

Switching on



CRUISE CONTROL

Press switch **1** until the  warning light is displayed in green on the instrument panel. The "Cruise control ON" message appears on the instrument panel accompanied by dashes to indicate that the cruise control function is in operation and waiting to store a cruising speed.

Activating cruise control

While the vehicle is moving a steady speed (above approximately 19 mph (30 km/h)), press the **2** (SET/-) switch or the **3** (RES/+) : switch: the function is activated and the current speed is taken into account.

The cruising speed replaces the dashes. Cruise control is confirmed when the memorised speed and warning

light appear in green .

If you try to activate the function below 19 mph (30 km/h), the message "Invalid Speed" will be displayed and the function will remain inactive.

Note: the cruise control speed can be changed at any time as long as the vehicle speed is between 19 mph and 112 mph (30 km/h and 180 km/h).

Driving



Please note that you must keep your feet close to the pedals in order to react in an emergency.

Once a cruising speed is registered and the cruise control function is active, you may lift your foot off the accelerator pedal.

Adjusting the cruising speed

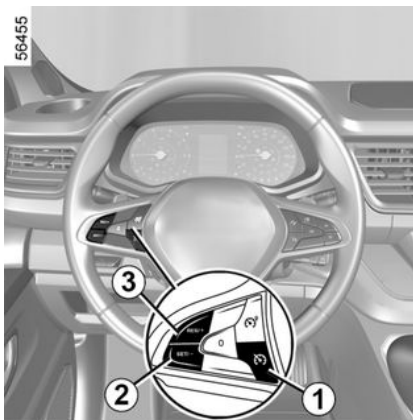

The cruising speed may be changed by repeatedly pressing the:

- switch **2** (SET/-) to reduce the speed;
- switch **3** (RES/+) to increase the speed.

Note: press and hold one of the switches to modify speed by successive increments.

Exceeding the cruising speed

The cruising speed may be exceeded at any time by depressing the accelerator pedal.

While it is being exceeded, the cruising speed flashes in red on the instrument panel. Then, release the accelerator pedal: after a few seconds, the vehicle will automatically return to its set cruising speed.



You must keep your feet near the pedals to be ready to react in an emergency.



If the cruise control is no longer available (after several attempts to activate it), contact an Approved Dealer.

CRUISE CONTROL

Temporarily not available

The system controls acceleration and deceleration of your vehicle using the engine and braking system. The system activates the brakes in order to maintain the set speed, the system applies limited braking. In the event of a steep descent, for example in a mountainous area, you must select a lower gear to benefit from engine braking.

To reduce the load imposed on the braking system and to prevent the brakes from overheating, the cruise control function may be temporarily interrupted and the "Check Cruise Control" message appears. The message disappears when the function becomes available again.

If the message remains, contact an approved dealer.

Putting the function on standby

The function is set to standby if you:

- the switch **4** (0);
- the brake pedal;

- the clutch pedal for a prolonged period or if the vehicle is in neutral for a prolonged period on vehicles equipped with a manual gearbox;
- shifting to neutral position on vehicles equipped with an automatic gearbox.

The cruising speed is stored and displayed in grey on the instrument panel.

Returning to the cruising speed



If a speed is stored, it can be recalled, once you are sure that the road conditions are suitable (traffic, road surface, weather conditions, etc.). Press the switch **3** (RES/+) if the vehicle speed is above 19 mph (30 km/h).

When the speed is stored, cruise control activation is confirmed by the display in green of the cruising speed and, depending on the vehicle, the warning light **6** appears.

Note: if the speed previously stored is much higher than the current speed, the vehicle will accelerate more rapidly to reach this threshold.

When the cruise control is set to standby, pressing switch **2** (SET/-) reactivates the cruise control function with-

CRUISE CONTROL

out taking into account the stored speed: it is the speed at which the vehicle is moving that is taken into account.

Switching off the function



Putting the cruise control on standby or switching it off does not cause a rapid reduction in speed: you must brake by pressing the brake pedal.

The cruise control function is interrupted:

- when you press the **1** switch. In this case, the speed is no longer stored;
- when you press the **5** switch. In this case, the speed limiter is selected and there is no stored speed.

The  warning light and the "Cruise control OFF" message disappear from the instrument panel to confirm that the function is deactivated.

ADAPTIVE CRUISE CONTROL

Operation



This function is an additional driving aid. It can under no circumstances replace the driver's responsibility to respect speed limits or to be vigilant.

The driver must always be in control of the vehicle. The driver must always adapt their speed according to the surroundings and traffic conditions. The adaptive cruise control must only be used on a motorway (or multi-lane road separated by a barrier). The cruise control must not be used in heavy traffic, on winding or slippery roads (black ice, aquaplaning, gravel) or during bad weather (fog, rain, side winds etc.).

There is a risk of accidents.

Based on information from a camera, the adaptive cruise control function gives you the option of maintaining a selected speed, known as the cruising speed, while keeping a safe distance from the vehicle in front in the same lane.

The system controls acceleration and deceleration of your vehicle using the engine and braking system.

The system's maximum range is approximately 140 metres. This may vary according to the road conditions (ground relief, weather conditions, etc.)



The adaptive cruise control does not trigger an emergency stop and its braking capability is limited.

The adaptive cruise control function can be activated from 19 mph (30 km/h), depending on conditions on the road (traffic, weather, etc.).

The function is indicated by the  symbol.

Note:

- the driver must observe the maximum speed limit and safe distances according to the legislation in the country where they are driving;
- the adaptive cruise control can brake the vehicle up to a third of the braking capacity. Depending on the situation, the driver may need to brake harder.

Location of the camera 1

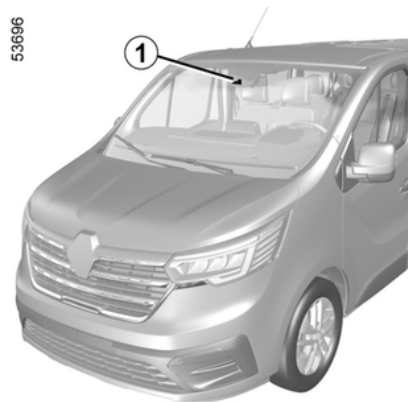

Make sure the windscreen is not obscured (by dirt, mud, snow, condensation etc.).

ADAPTIVE CRUISE CONTROL

Controls

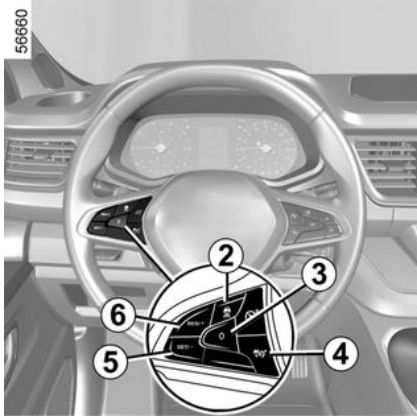

2. Safe distance settings
3. Put the function on standby (with cruising speed stored) (0).
4. Adaptive cruise control main stop/start switch .
- 5 Activate, store and decrease the cruising speed (SET/-).
6. Switch to activate and increase cruising speed or to recall the memorised cruising speed (RES/+).

Displays



The camera should be kept clean and free of any modifications in order to ensure the proper operation of the system.



7. Adaptive cruise control warning light.
8. Vehicle in front.
9. Stored safe distance
10. Stored cruising speed.

Switching on

Press the switch **4**.

The  warning light appears in grey and the "Adaptive cruise control ON" message appears on the instrument panel accompanied by dashes to indicate that the function is activated and waiting to store a cruising speed. The "Adaptive Cruise Ctl unavailable" message is displayed on the instrument panel.

Activating cruise control



Important: you should keep your feet near the pedals at all times to prepare for any event.

While the vehicle is moving at a steady speed, press switch **5** (SET/-) or **6** (RES/+) to activate the function and store the current speed. The minimum cruising speed is 19 mph (30 km/h). The cruising speed **10** replaces the dashes and the  warning light and the cruising speed are displayed in green to confirm that the cruise control function is in operation.

ADAPTIVE CRUISE CONTROL

If you try to activate the function above 105 mph (170 km/h) or below 19 mph (30 km/h), the "Invalid Speed" message is displayed and the function will remain inactive.

Once a cruising speed is memorised and the cruise control function is active, you may lift your foot off the accelerator pedal.

Safe distance control activation

As soon as cruise control is activated, the default safe distance **9** is displayed in green on the instrument panel. The default safe distance corresponds to approximately two seconds (see relevant section).

If the system detects a vehicle in your lane, an outline of a vehicle **8** appears above the distance gauge **9** on the instrument panel.

Your vehicle adapts its speed to that of the vehicle in front and applies the brakes if necessary (the brake lights come on) in order to maintain the distance displayed on the instrument panel.

Note: the size of the **8** outline varies according to the distance separating you from the vehicle in front. The larger the outline, the closer the vehicle in front.

Setting the cruising speed

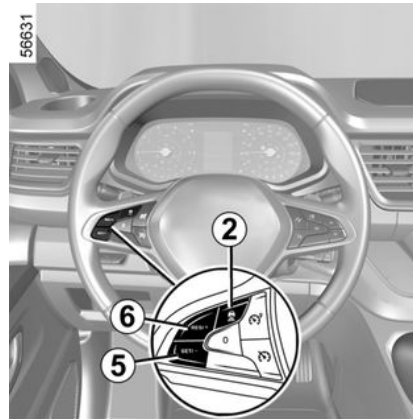

You can vary the speed by repeatedly pressing (small increments) or pressing and holding (large increments) switch **5** or **6**:

- switch (SET/-) **5** to reduce the speed;
- switch (RES/+) **6** to increase the speed.

Activating cruise control with speed limit sign recognition

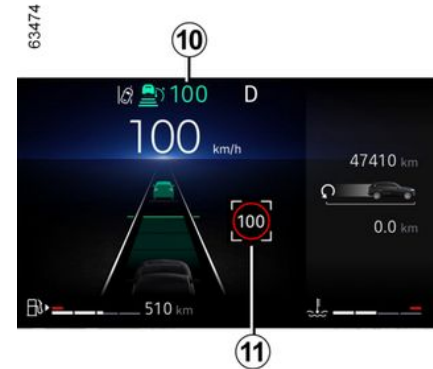

(depending on the vehicle)

If the vehicle is equipped with the "Road sign detection" function → **242**, press switch SET/- **5** or RES/+ **6** to adapt the vehicle speed to the speed limits **11** detected by the camera.

When passing the sign, the cruising speed **10** adopts the value of the detected speed **11**.

ADAPTIVE CRUISE CONTROL

Adjusting the following distance



You can vary the safe distance from the vehicle in front at any time by pressing switch **2** repeatedly.

The horizontal distance gauge on the instrument panel indicates the various available safe distances:

- distance gauge **A**: long distance (corresponding to approximately 2.4 seconds);
- distance gauge **B**: intermediate distance 2 (corresponding to approximately two seconds);
- distance gauge **C**: intermediate distance 1 (corresponding to approximately 1.6 seconds);

- distance gauge **D**: short distance (corresponding to approximately 1.2 seconds).

The selected distance gauge appears in green on the instrument panel. The other gauges remain in grey.

Note: the distance must be set according to the traffic level, local regulation and weather conditions.



The following distance setting is stored by the system between each activation of Adaptive Cruise Control and for the next vehicle start cycle.

Exceeding the cruising speed



The cruising speed may be exceeded at any time by applying the accelerator pedal.

If it is exceeded, the cruising speed **10** appears in red.

Then, release the accelerator pedal: the cruise control and safe distance control will automatically resume the speed and distance instructions that you had previously selected.

The distance gauge flashes if the distance between your vehicle and the vehicle in front is less than the safe distance selected: the "Safe Distance Control" function is no longer active.

ADAPTIVE CRUISE CONTROL

Overtaking manoeuvre

If you wish to overtake the vehicle in front, activating the indicator will temporarily cancel the safe distance control and enable an acceleration speed sufficient to complete overtaking.

Putting the function on standby



Putting the adaptive cruise control on standby or switching it off does not cause a rapid reduction in speed: you must brake by pressing the brake pedal if necessary.

You can set the function to standby when:

- you press switch **3** (0);
- you apply the brake pedal while the vehicle is moving.

The function is deactivated by the system if:

- you unbuckle the driver's seat belt;
- you open one of the opening elements;
- you press the engine start/stop button;
- the slope is too steep;

- the vehicle speed is above 105 mph (170 km/h);
- certain driving aids and correction devices are triggered (active emergency braking, ABS, ESC, etc.);
- when you press the clutch pedal for a prolonged period or upon prolonged neutral position on vehicles equipped with a manual gearbox.

If it goes on standby, this is confirmed when the warning lights appear in grey and the "Adaptive Cruise Control disconnected" message appears on the instrument panel.

Exit from standby

Based on the stored cruising speed

If a speed is stored, it can be recalled, once you are sure that the road conditions are suitable (traffic, road surface, weather conditions, etc.).

Press switch **6** (RES/+) within the valid speed range.

When the stored speed is recalled, activation of the cruise control is confirmed by the illumination of the cruising speed in green.

Note: if the stored speed is higher than the current speed, the vehicle will accelerate to reach that speed.

Based on the current speed

When the cruise control is set to standby, pressing switch **5** (SET/-) reactivates the cruise control function without taking into account the stored speed: it is the speed at which the vehicle is moving that is taken into account.

"Take control of the vehicle" warnings



In some situations (e.g. coming upon a much slower vehicle, vehicle in front changing lanes quickly, etc.) the system may not have time to react.

Depending on the situation, the system sounds a beep associated with:

ADAPTIVE CRUISE CONTROL

– the orange alert **E** if the situation requires the driver's attention;
or

– the red alert **F** accompanied by the "Brake" message if the situation requires the driver's immediate attention.

In all situations, react accordingly and perform the appropriate manoeuvres.

Switching off the function

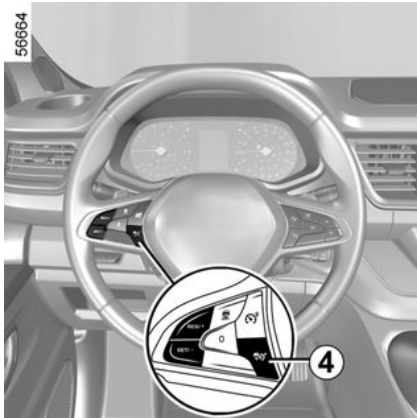

The adaptive cruise control function is deactivated when you press the **4** switch.

The warning light  disappears from the instrument panel to confirm that the function is no longer active.

Temporary unavailability

The green warning light  disappears to confirm that the function has been automatically deactivated.

Conditions in certain geographical areas may hinder the function, for example:

- arid zones, tunnels, long bridges or lightly used roads without road lines, without signs or trees nearby;
- a military or airport zone.

You must leave such areas in order for the function to work.

In all cases, if the message is not erased after the engine is restarted, please contact an authorised dealer.

 The system controls acceleration and deceleration of your vehicle using the engine and braking system. The system activates the brakes in order to maintain the set speed, the system applies limited braking. In the event of a steep descent, for example in a mountainous area, you must select a lower gear to benefit from engine braking. To reduce the load imposed on the braking system and to prevent the brakes from overheating, the adaptive cruise control function may be temporarily interrupted and the "Check adaptive cruise control" message appears. The message disappears when the function becomes available again. If the message remains, contact an approved dealer.

Operating faults

If an operating fault is detected on one or more components of the system, the adaptive cruise control function is interrupted.

ADAPTIVE CRUISE CONTROL

Depending on the type of malfunction, the message is displayed on the instrument panel:

– "Check Front camera" accompanied, depending on the vehicle, by the



warning light;

– "Check vehicle" accompanied by the



warning light;

– "Check camera/radar".

Consult an approved dealer.

Limitations of system operation

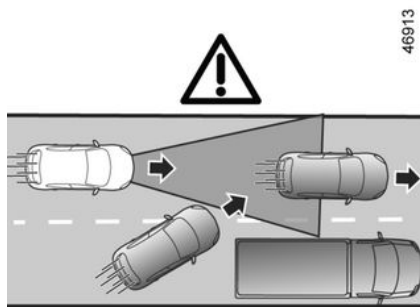

G

Vehicle detection

The system detects only vehicles (cars, trucks, motorbikes) that are

moving in the same direction as your vehicle.

A vehicle entering the same traffic lane (example **G**) will only be taken into account by the system once it has fully moved into the lane within the camera's detection zone.

The system may trigger abrupt or delayed braking.

The system cannot detect:

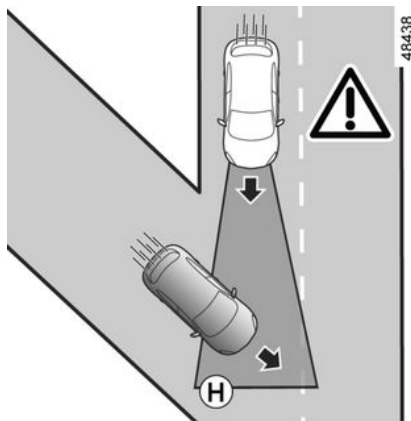

- vehicles arriving at intersections: slip road (example **H**);
- vehicles driving on the wrong side of the road or reversing towards you.



The adaptive cruise control must only be used on a motorway (or multi-lane road separated by a barrier).

Detection during cornering

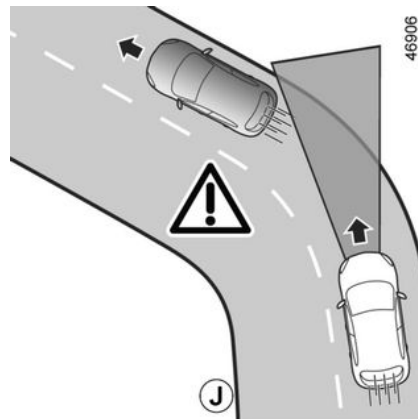

When entering a corner or bend, the camera may temporarily be unable to detect the vehicle in front (example **J**).

The system may trigger an acceleration.

When exiting a bend, the system's detection of the vehicle in front may be disrupted or delayed.

ADAPTIVE CRUISE CONTROL

The system may trigger abrupt or delayed braking.

Detection of vehicles in adjacent lanes



The system may detect vehicles driving on an adjacent lane when:

- you drive into a bend (example *K*);
- you are driving on a road with narrow lanes;
- the speed of the vehicle on the adjacent lane is slower and if one of these vehicles is located too close to the lane of the other.

The system may incorrectly trigger vehicle slowing or braking.

Vehicles hidden due to variations in ground relief

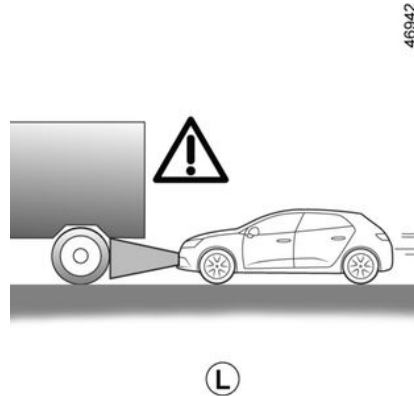

The system will not register vehicles driving uphill or downhill when hidden by terrain or when located outside the camera's detection zones.

Vehicles outside the camera detection zones

The system will react late or not at all if detected vehicles are outside the camera detection zone, particularly in the following situations:

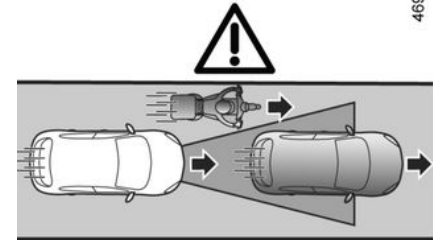

(M)

- vehicles transporting long objects which exceed the lane;
- vehicles insufficiently centred in the lane;
- narrow vehicles which are very close (example *M*).

ADAPTIVE CRUISE CONTROL

Stationary and slow moving vehicles

3

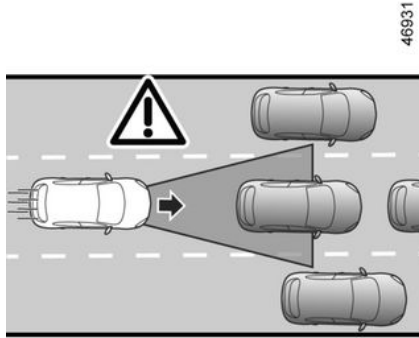

N

When your speed is over approximately 31 mph (50 km/h), **the system does not detect:**

- stationary vehicles (example **N**);
- very slow moving vehicles.

When your speed is less than approximately 31 mph (50 km/h), **the system may not react or may react very late** to:

- stationary vehicles (example **N**);
- very slow moving vehicles;

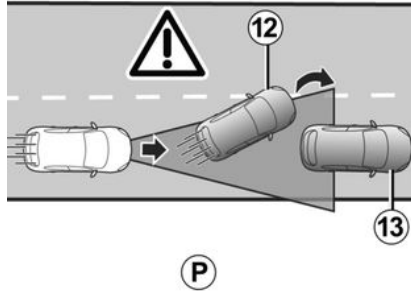

– preceding vehicles **12** that change lane or discovering a slow or stationary vehicle **13** (example **P**).



Always be ready to take control of your vehicle when you come upon stationary or very slow-moving vehicles (example **N).**

The adaptive cruise control does not trigger an emergency stop and its braking capability is limited.

Non-detection of fixed obstacles and objects of a small size

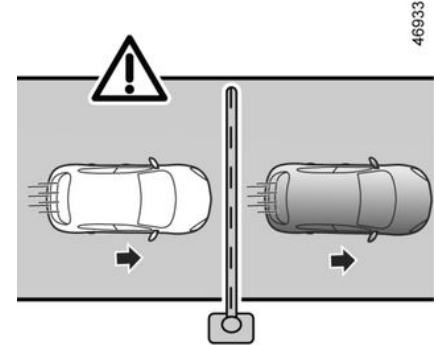

Q

The system cannot detect:

- pedestrians, bicycles, scooters, shopping trolleys, caddies, etc.;
- animals;
- fixed obstacles (toll barriers, walls, etc.) (example **Q**).

These are not taken into account by the system. They do not trigger any alert or reaction by the system.

ADAPTIVE CRUISE CONTROL

Warning



This function is an additional driving aid. It can under no circumstances replace the driver's responsibility to respect speed limits and safe distances or to be vigilant.

The driver must always be in control of the vehicle.

The driver must always adapt their speed to the surroundings and driving conditions, regardless of system indications.

Except for lines delimiting lanes, traffic indicators (traffic lights, signs, pedestrian crossings etc.) are not recognised by the system. These do not trigger any alert or reaction by the system.

The system should under no circumstances be taken to be an obstacle detector or an anti-collision system.

The adaptive cruise control must only be used on a motorway (or multi-lane road separated by a barrier).

System servicing/repairs

– In the event of an impact, the camera alignment may be changed and its operation may consequently be affected. Deactivate the system and consult an authorised dealer.

– Any work in the area where the camera is located (replacements, repairs, windscreen modifications, paintwork, etc.) must be carried out by a qualified professional.

Only an authorised dealer is qualified to service the system.

Deactivating the function

You must deactivate the function if:

- the vehicle is travelling on a winding road;
- the vehicle is being towed (breakdowns);
- the vehicle is towing a trailer or a caravan;
- the vehicle arrives at a toll point, a roadwork area or on a narrow lane;
- the vehicle is being driven up or down a very steep slope;
- the visibility is poor (glaring sun, fog, etc.);
- the vehicle is being driven on a slippery road surface (rain, snow, gravel, etc.);
- the weather conditions are poor (rain, snow, side winds, etc.);
- the camera area has been damaged (e.g. on the inside or outside of the windscreen);
- the windscreen is cracked or distorted.

ADAPTIVE CRUISE CONTROL

In the event of the system behaving abnormally, deactivate it and contact an authorised dealer.

3



In the event of system disturbance

Some conditions can disturb or damage the system's operation, such as:

- windscreen obscured (by dirt, ice, snow, condensation etc.);
- poor weather conditions (snow, heavy rain, hail, black ice, etc.);
- poor visibility (night, fog, etc.);
- poor contrast between the vehicle preceding it and the surrounding area (e.g. white vehicle in a snowy area, etc.);
- being dazzled (glaring sun, lights of vehicles travelling in the opposite direction; etc.);
- narrow, winding or undulating road (tight bends, etc.);
- a slower vehicle with a significant difference in speed;
- use of mats not adapted to the vehicle. On the driver's side, only use mats suitable for the vehicle, attached with the pre-fitted components, and check the fitting regularly. Do not lay one mat on top of another. **There is a risk of wedging the pedals.**

In these cases, the system may wrongly intervene.

Risk of unwanted braking or acceleration.

Many unforeseen situations may affect the system operation. Certain objects or vehicles that appear in the camera detection zone may be interpreted by the system incorrectly, possibly leading to inappropriate acceleration or braking.

You should always be attentive to sudden events that might occur while you are driving. Always keep your vehicle under control by keeping your feet near the pedals, so that you are ready to act in any event.

PARKING AIDS

Parking distance control

56596



Ultrasonic sensors, indicated by arrows **1**, are fitted in the bumpers to detect obstacles near the vehicle.

This measurement is indicated by beeps which become more frequent the closer you come to the obstacle, until they become a continuous beep when the vehicle is approximately 20 to 30 centimetres from the obstacle.

Depending on the equipment, the system detects obstacles in front and, behind and to the sides of the vehicle.

The Park Assist system is only activated when the vehicle is driven at a speed below approximately 6 mph (10 km/h).

The function does not take into account towing or carrying systems that are not recognised by the system.



This function is an additional driving aid. Under no circumstances should it replace the driver's care or responsibility whilst reversing.

The driver should always be ready for sudden incidents while driving: always ensure that there are no small, narrow moving obstacles (such as a child, animal, pushchair, bicycle, stone, post, etc.) in the blind spot when manoeuvring.

Location of the ultrasonic sensors **1**

Ensure that the area around the ultrasonic sensors indicated by the arrows **1** is not obscured (by dirt, mud, snow, a badly fitted/attached number plate), impacted, modified (including paintwork) or obstructed by any accessory fitted to the rear and/or, depending on the vehicle, to the front or sides of your vehicle.

Operation

56597

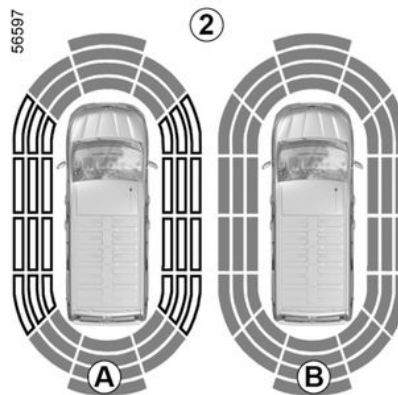

The screen **2** shows the vehicle surroundings, accompanied by beeps.

Depending on the equipment, it may be necessary to travel a few metres before the side detection is activated.

If all areas have a grey background, the whole area around the vehicle is being monitored:

- display **A**: analysis of vehicle surroundings in progress;
- display **B**: analysis of vehicle surroundings complete.

PARKING AIDS

Obstacle detection

56598

C



The system is able to detect most objects located near the rear and, depending on the equipment, near the front and sides of the vehicle.

The audible signal frequency will increase as the vehicle approaches an obstacle, until it becomes a solid beep at approximately 20 cm for an obstacle detected on the sides and approximately 30 cm for an obstacle detected to the front or rear.

The area where the obstacle has been detected is displayed (display **C**). Depending on the vehicle, the area is displayed in green, orange (or yellow depending on the vehicle) or red, de-

pending on the proximity of the detected object.

Note:

i In the event of a change in trajectory during a manoeuvre, the risk of collision with an obstacle may be signalled late.

Special case of obstacles detected on the side

56599

D

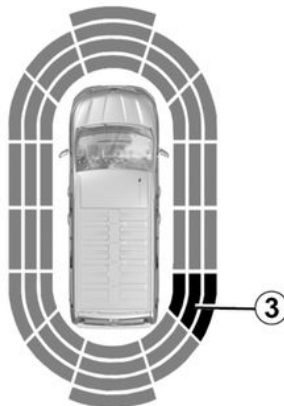

Depending on the direction of the wheels, the system determines the trajectory of the vehicle and notifies the driver if there is a risk or not of a colli-

sion with an obstacle **3** to the side of the vehicle.

If a side obstacle is detected:

- the beeps become faster and then sound continuously as the obstacle gets nearer. Green, orange and red zones will be shown on the display **D**;
- if there is no risk of collision, no beep will sound when approaching the obstacle. Depending on the vehicle, the area where the obstacle **3** has been detected is shown interspersed.

i In the event of a change in trajectory during a manoeuvre, the risk of collision with an obstacle may be signalled late.

PARKING AIDS

Activation/deactivation

Activation/deactivation from the multimedia screen

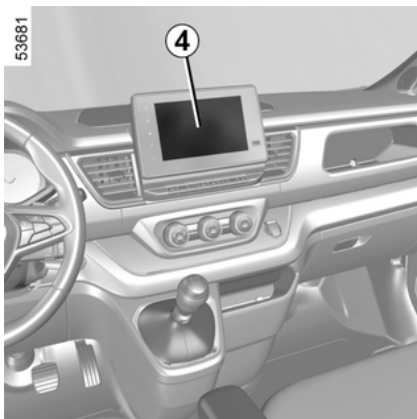

From the "Vehicle" world on your multimedia screen **4**, press the "Parking aids" menu. Activate or deactivate areas covered by the ultrasonic detectors.

Note: depending on the vehicle, the "rear" detection zone cannot be deactivated.

Activating/deactivating the system from the trip computer

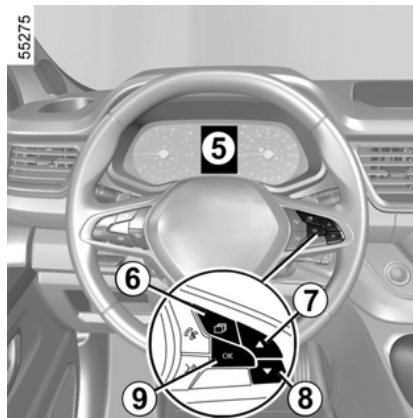

– With the vehicle stationary, press the **6** switch as many times as required to reach the "VEHICLE" tab;
– press control **7** or **8** repeatedly to reach the "DRIVING ASSIST" menu. Press switch **9** OK;
– press control **7** or **8** repeatedly until you reach the "Parking" menu. Press switch **9** OK;
– press switch **8** OK to activate or deactivate the function;

- function activated
- function deactivated

Parking distance control automatic deactivation

The system is deactivated:

- when the vehicle speed is above approximately 6 mph (10 km/h);
- depending on the vehicle, when the vehicle is stationary for more than approximately five seconds and an obstacle is detected (such as when in a traffic jam, etc.);
- when you are in **N** or **P** position;
- when an operating fault is detected.

Note: depending on the vehicle, if the vehicle is fitted with a towbar recognised by the system, only the rear Park Assist function is deactivated.

Adjustment



For safety reasons, carry out any adjustments while the vehicle is stationary.



Each time the vehicle is started, the function continues the mode saved the last time the engine was stopped.

PARKING AIDS

Adjusting settings from the multimedia screen 4

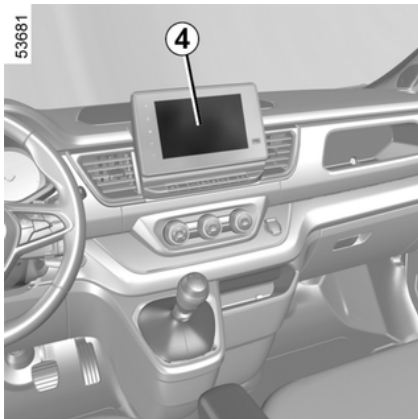

Vehicle stationary, from the "Vehicle world" on your multimedia screen 4, press the "Parking aids" menu.

Please refer to the multimedia instructions for further information.

Adjusting settings from the trip computer 5

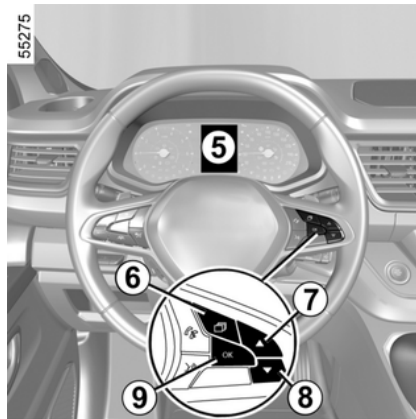

- With the vehicle stationary, press the 6 switch as many times as required to reach the "VEHICLE" tab;
- press control 7 or 8 repeatedly to reach the "DRIVING ASSIST" menu. Press switch 9 OK;
- press control 7 or 8 repeatedly until you reach the "Parking" menu. Press switch 9 OK.

Deactivating the system sound

(depending on the vehicle)

Activate or deactivate the parking distance control sound.

Note: if you deactivate the sound, you will no longer be notified with beeps when approaching an obstacle.

Parking distance control audio volume

Adjust the Park Assist volume using the volume bar.

 Each time the vehicle is started, the function continues the mode saved the last time the engine was stopped.

Special cases

You can manually deactivate sound alerts or, depending on the vehicle, the detection zone concerned:

- if towing, carrying or trailer equipment that is unrecognised by the system is present in front of the ultrasonic sensors;
- in the event of damage to the ultrasonic sensors.

Note: if the sound is deactivated, the displays will continue to warn you erratically.

PARKING AIDS

Operating faults

When the system detects a malfunction: either a sound signal warns you for about three seconds when the reverse gear is engaged, accompanied by the "Check Parking sensors" message on the instrument panel, or the system does not produce a sound or display when the reverse gear is engaged.

Check that the ultrasonic sensors are clean. If the fault persists, consult an approved dealer.



System servicing/repairs

- In the event of an impact, the alignment of the ultrasonic sensors may be altered and its operation may consequently be affected. Deactivate the function and consult an authorised dealer.
- Any work in the area where the ultrasonic sensors are located (repairs, replacements etc.) must be carried out by a qualified professional.

Only an authorised dealer is qualified to service the system.

System disturbance

Some conditions can disrupt or damage the system operation, for example:

- poor weather conditions (rain, snow, hail, black ice, etc.);
- some types of noise (motorcycle, lorry, pneumatic drill, etc.);
- fitting an non-compatible towing ball or hook.

Risk of false alarms or absence of warnings

If the system behaves abnormally contact an authorised dealer.

Limitation of the system operation

- The area around the sensors must be kept clean and free of any modifications in order to ensure the proper operation of the system.
- Small objects moving close to the vehicle (motorcycles, bicycles, pedestrians, etc.) may not be recognised by the system.
- The system may not detect objects that are too close to the vehicle.
- The system may not provide a warning when the other vehicles or objects are travelling at a significantly different speed.
- When there is a change in trajectory during a manoeuvre, the system may be slow in reporting obstacles.

PARKING AIDS

Reversing camera



This function is an additional aid. It cannot, therefore, under any circumstances replace the vigilance or the responsibility of the driver.

The driver should always be ready for sudden incidents while driving: always ensure that there are no small, narrow moving obstacles (such as a child, animal, pushchair, bicycle, stone, post, etc.) in the blind spot when manoeuvring.

Operation

36620

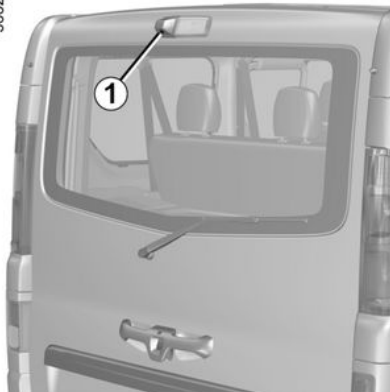

When shifting to reverse gear, the camera **1** located on the tailgate or, depending on the vehicle, on the rear hinged door, transmits a view of the area behind the vehicle to the rear view mirror **2** or, depending on the vehicle, to the multimedia display **3** accompanied by two moving or fixed guide lines **4** and **5**.



Note: make sure that the reversing camera is not obscured (by dirt, mud, snow, condensation, etc.).

Settings

(depending on the vehicle)

PARKING AIDS

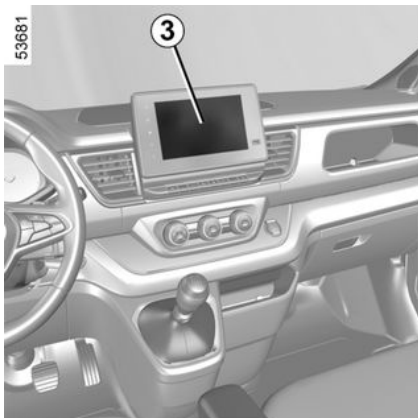

With the engine running, from the multimedia screen **3** you can add or remove the guide lines and adjust the camera image settings (brightness, contrast, etc.). Please refer to the multimedia instructions for further information.

Moving guide line **4**

(depending on the vehicle)

This is shown in blue on the multimedia display **3**. It indicates the vehicle trajectory according to the position of the steering wheel.

Fixed guide line **5**

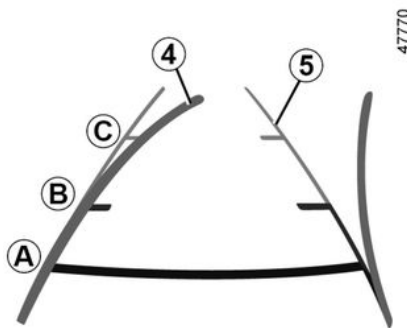

The fixed gauge includes coloured markers **A**, **B** and **C** indicating the distance behind the vehicle:

- **A** (red) at approximately 30 centimetres from the vehicle;
- **B** (yellow) at approximately 70 centimetres from the vehicle;
- **C** (green) at approximately 150 centimetres from the vehicle.

This gauge remains fixed and indicates the vehicle trajectory if the wheels are in line with the vehicle.

This system is initially used with the aid of several gauges (mobile for trajectory and fixed for distance). When the red zone is reached, use the bumper image to stop accurately.

Operating faults

When reverse gear is engaged, if the system detects an operating fault, a black screen is displayed temporarily on the multimedia screen **3**.

This may be caused by a fault affecting the camera or screen (clearness, fixed image, delayed communication etc.).

If the temporary display of the black screen persists, please consult an approved dealer.

PARKING AIDS

i The screen shows a reverse image.

The frames are a representation projected on a flat surface. This information is to not be taken into account when superimposed on a vertical object or an object on the ground.

Objects which appear on the edge of the screen may be deformed.

In very bright light (snow, vehicle in sunshine, etc.), the camera vision may be adversely affected. If the rear doors are open or incorrectly closed, the "WARNING: Boot Open" message appears and, depending on the vehicle, the camera display disappears.

Difference between the estimated distance and actual distance

Reversing towards a steep uphill slope

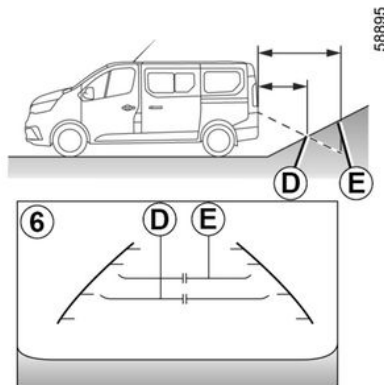

The fixed guidelines **6** show the distances as closer than they actually are.

The objects shown on the screen are actually further away on the slope.

For example, if the screen displays an object at **D**, the actual distance of the object is at **E**.

Reversing towards a steep downhill slope

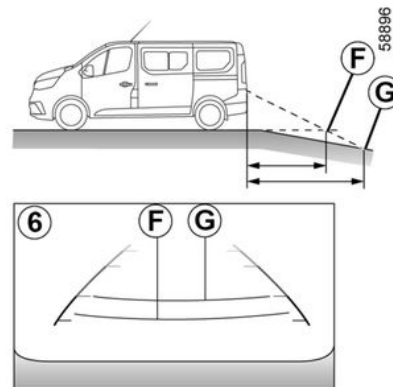

The fixed guidelines **6** show the distances as further than they actually are.

Therefore, the objects shown on the screen are actually closer on the slope.

For example, if the screen displays an object at **G**, the actual distance of the object is at **F**.

PARKING AIDS

Reversing towards a protruding object

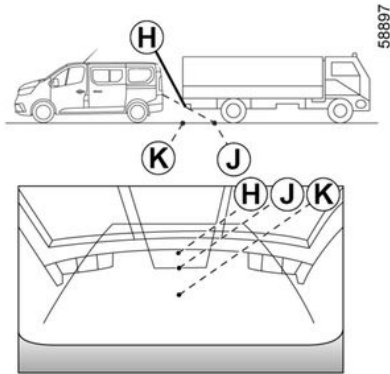

Position **H** seems further than position **J** on the screen. However, position **H** is at the same distance as position **K**.

The trajectory indicated by the fixed and mobile guidelines do not take into account the height of the object. So there is a risk that the vehicle may collide with the object when reversing towards position **K**.

EMERGENCY CALL

3



In the event of an accident, if the location and traffic conditions permit, stay close to the vehicle in order to be able answer the call centre quickly if necessary.



To guarantee your safety and the proper operation of the system, any operation carried out on the battery (removal, disconnection, etc.) must be carried out by a qualified specialist.

Risk of serious burns or electric shocks.

You must respect the replacement intervals (without exceeding them) as stated in the maintenance document.

The battery is a specific type. Please ensure it is replaced with the same type. Call an approved dealer.



Without the emergency call feature, the system is not trackable and will not be under constant surveillance. Data is automatically and constantly erased, and the system stores only the last three positions of the vehicle.

According to local legislation, data is only sent in the event of an emergency call. Data sent to the call centre is treated according to the personal data protection laws applicable in the country where you are located. The system stores activity history data for 13 hours only.

The vehicle owner has the right of access to their data. They can request that the data be corrected, deleted or locked.

If the vehicle is equipped, the emergency call function can be used to call the emergency services (without charge) automatically or manually in the event of an accident or illness, reducing the time it takes for the emergency services to arrive.

Note: the emergency call operates:

- in countries covered by the telematics services and infrastructure associated and compatible with the system;
- depending on the network coverage in the geographical region where the vehicle is being driven.

If you use the emergency call function to report an accident which you have witnessed, this implies stopping where traffic conditions allow in order for the emergency services to locate your vehicle and therefore the location of the reported accident.

In all cases, comply with local legislation.



Use the emergency call only in the event of an emergency you are involved in, if you witness an accident or if you feel ill.

EMERGENCY CALL

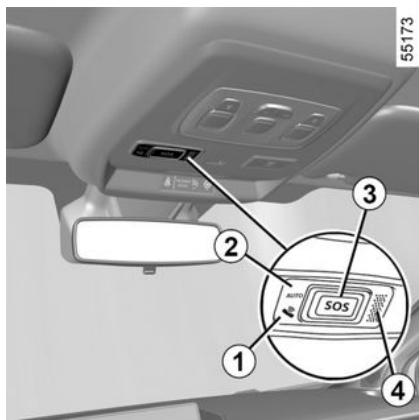

1. System operation warning light:
 - green: operational (network available);
 - off: non-operational (network unavailable);
 - red: operation fault;
 - flashing green: call in progress.
2. Automatic mode warning light.
3. SOS button.
4. Microphone.
5. Speaker.

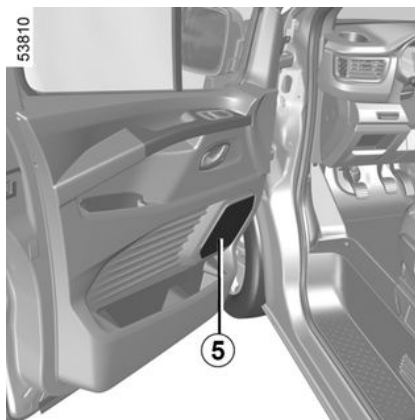

- A call always takes place as follows:
- the call is initiated with the emergency services;
 - data related to the incident (manufacturer's plate, time of the call, last locations, vehicle direction, etc.) is sent;
 - voice communication takes place with the emergency services;
 - if necessary, emergency assistance is called.

- There are two emergency call modes:
- automatic mode;
 - Manual mode.

Automatic mode

If the automatic mode warning light **2** appears in green, this confirms that the automatic system is activated.

The emergency call starts automatically in the event of an accident that has required the activation of the protective equipment (seat belt pretensioners, Airbag etc.).

Manual mode

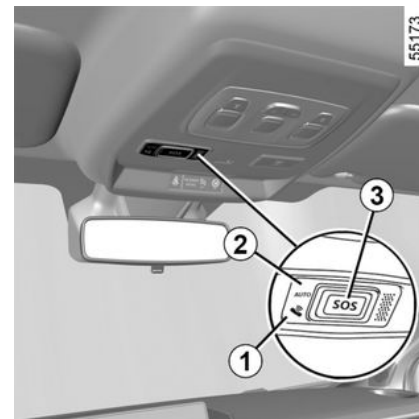

The emergency call can be initiated by:

- pressing and holding the button **3** for at least three seconds;
- or

EMERGENCY CALL

– pressing the button **3** five times within ten seconds.

If the button was pressed by mistake, it is possible to cancel the call by pressing and holding the button **3** for around two seconds, before the call is connected to the call centre.

Once a call is established, only the call centre can end it.

 The system operates with a dedicated battery. The battery service life is approximately four years (the warning light **1** appears in red to warn you). Consult an approved dealer.

Operating faults



In some cases, the emergency call may not work (e.g. low battery, etc.).

When the system detects an operating fault, the warning light **1** appears in red for over 30 minutes. Consult an approved dealer as soon as possible.

AIR VENTS, HEATING AND AIR CONDITIONING

Air vents, air outlets

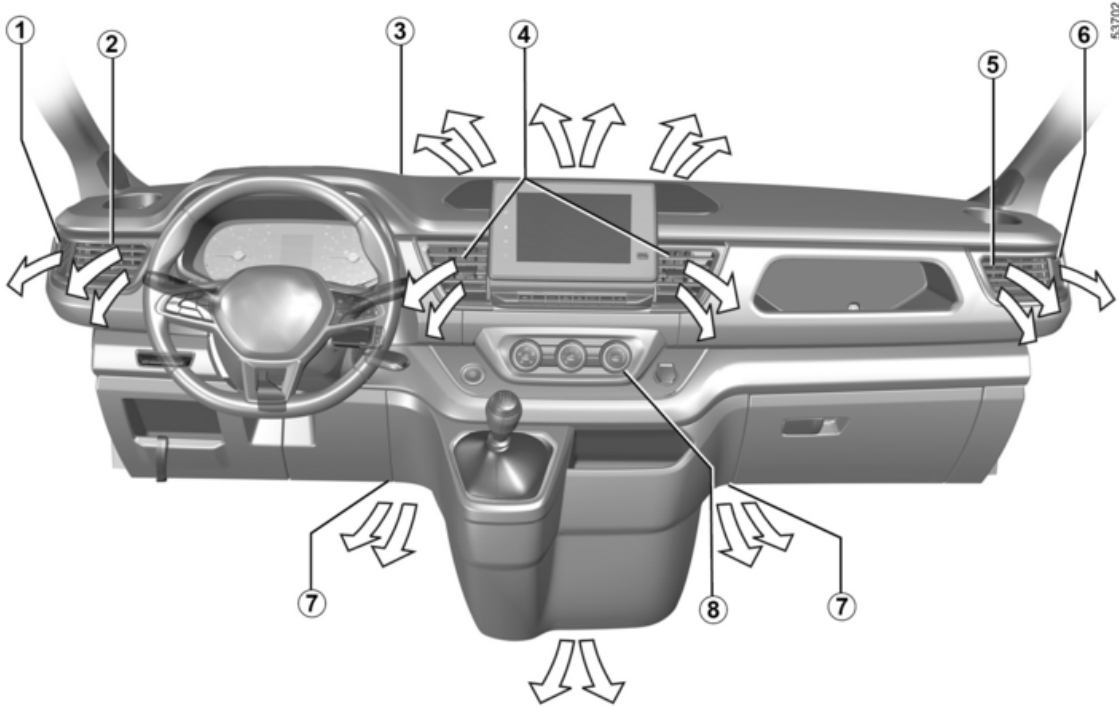

53702

4

AIR VENTS, HEATING AND AIR CONDITIONING

- 1 Side window demister outlet
- 2 Left-hand air vent
- 3 Windscreen demisting vents
- 4 Centre air vents
- 5 Right-hand air vent
- 6 right-hand side window demister outlet
- 7 Passenger footwell heater outlets
- 8 Control panel

AIR VENTS, HEATING AND AIR CONDITIONING

Centre air vents

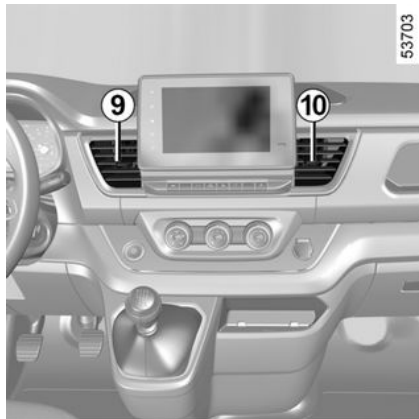

Air flow

To close the left-hand central air vent, slide the tab **9** to the left.

To close the right-hand central air vent, slide the tab **10** to the right.

Air flow direction

To direct the air flow, swivel the side air vent **9** or **10**.

Side air vents

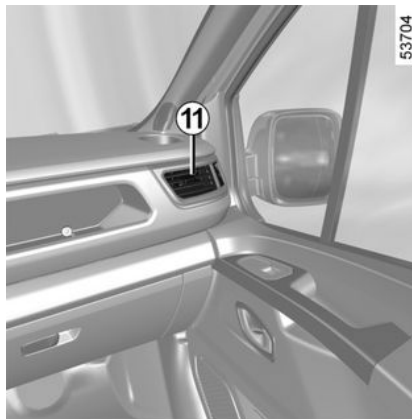

Air flow

To close the left-hand side air vent, slide the tab **11** fully to the right.

To close the right-hand side air vent, slide the tab **11** fully to the left.

Air flow direction

To direct the air flow, swivel side air vent **11**.

To remove bad odours from your vehicles, only use the systems designed for this purpose. Consult an approved dealer.



Do not add anything to the vehicle's ventilation circuit (for example, to remove bad odours).

There is a risk of damage or of fire.

AIR VENTS, HEATING AND AIR CONDITIONING

Manual air conditioning

4



53705

AIR VENTS, HEATING AND AIR CONDITIONING

Controls

The controls will depend on the vehicle equipment level.

1. Distribution of air.
2. De-icing/demisting of the door mirrors and, depending on the vehicle, the rear screen.
3. Adjusting the ventilation fan speed.
4. Air recirculation.
5. Adjusting the air temperature.
6. Air conditioning.

Information and advice on use → 295

Adjusting the air temperature

Turn control **5** to obtain the desired temperature. The further towards the red the slide is, the higher the temperature will be.

Adjusting the ventilation fan speed

Move control **3** from 0 to 4. The further the control is positioned to the right, the greater the amount of air blown into the passenger compartment. If you want to shut off the air flow, set the control **3** to 0.

The system is deactivated: the ventilation speed for the passenger compartment air is zero (vehicle stationary),

you can however still feel a slight flow of air when the vehicle is moving.

Note: prolonged use of this control in position 0 may lead to condensation forming on the side windows and windscreen as well as problems due to the air not being renewed in the passenger compartment.

Switching passenger compartment isolation mode/air recirculation mode on.

Press the button **4** and the warning light will light up.

Under these conditions, air is taken from the passenger compartment and is recirculated, with no air being taken from outside the vehicle.



If the air conditioning is not activated (the "A/C" indicator light built into the button **6** goes out), prolonged use of recirculated air may cause condensation to form on the side windows and windscreen as well as other problems due to the presence of non-recirculated air in the passenger compartment. To avoid this, air recirculation is disabled automatically after a certain time.

Air recirculation operates as follows:

- isolating the vehicle from the external atmosphere (e.g. when driving in polluted areas, etc.);
- to bring the passenger compartment to the desired temperature as quickly as possible.

Rear screen de-icing and demisting

With the engine running, press button **2**. The integrated indicator light comes on.

This function allows rapid electric demisting of the rear screen and, depending on the vehicle, electric de-icing of the rear view mirrors.

To exit this function, press button **2** again. Demisting automatically stops.

Rapid demisting

Passenger compartment isolation/air recirculation deactivated (the indicator light on button **4** is switched off):

- press button **2** (the indicator light comes on) and set the control **1** to the

demisting position ;

- set control **3** and **5** to position:
 - fan speed to position 3 or 4;
 - maximum temperature;

AIR VENTS, HEATING AND AIR CONDITIONING

– press button **6** (the built in indicator light comes on): triggering the air conditioning accelerates demisting by drying out the air.

Distribution of air in the passenger compartment

Turn control **1** to choose the distribution option.



The air flow is directed to the dashboard vents.



The air flow is directed towards the dashboard vents and the footwells.



The air flow is mainly distributed between the front and rear footwells and the dashboard vents.

Close the dashboard vents to direct all the air to the foot wells.



The air flow is distributed between all the air vents, the front side window demisting vents, the windscreen demisting vents and the footwells.



All the air is then directed to the windscreen and front side window demisting vents.

Switching the air conditioning on or off

The air conditioning is switched on (indicator light lit) or off (indicator light off) using button **6**

Activation is not possible if control **3** is set to "0".



Do not open the refrigerant circuit. The fluid may damage eyes or skin.

The air conditioning system is used for:

- lowering the temperature inside the passenger compartment;
- eliminating condensation more quickly.

The air conditioning does not operate when the exterior temperature is low.

Using the air conditioning in hot weather

To adjust the temperature quickly in hot weather, switch on the air conditioning using button **6**.

Activate air recirculation by pressing button **3**.

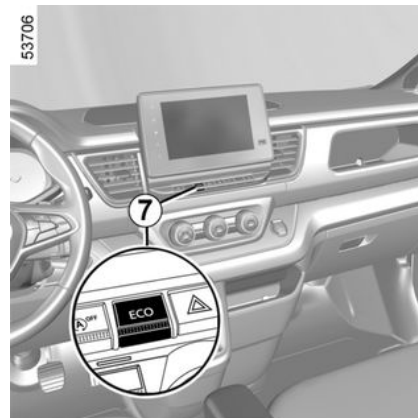

On vehicles equipped with ECO mode (switch 7): when activated, ECO mode can reduce the performance of the heating and/or air conditioning ➔ **199**.

AIR VENTS, HEATING AND AIR CONDITIONING

Automatic climate control

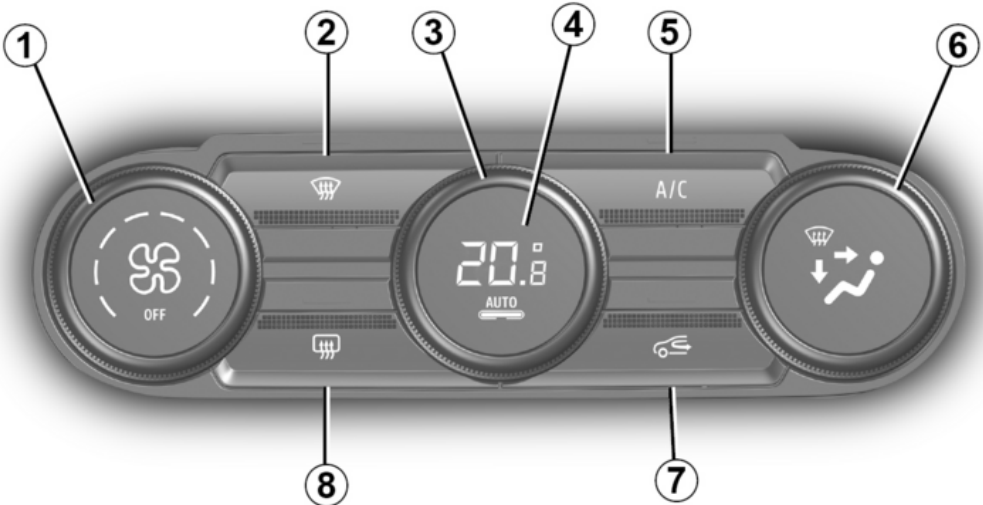

53861

4

AIR VENTS, HEATING AND AIR CONDITIONING

The controls

(depending on the vehicle)

1. Adjusting the ventilation fan speed.
2. "Clear View" function.
3. Adjusting the air temperature.
4. Automatic mode.
5. Air conditioning control.
6. Distribution of air in the passenger compartment.
7. Air recirculation.
8. De-icing/demisting of the rear screen and, depending on the vehicle, the rear view mirrors.

Automatic mode

The automatic climate control system guarantees comfort in the passenger compartment and good visibility (except in the event of extreme conditions), whilst optimising consumption. The system controls the ventilation speed, air distribution, air recirculation, and starting and stopping the air conditioning and air temperature.

AUTO: allows the selected comfort level to be best attained, depending on the exterior conditions. Press the button **4**.

Adjusting the ventilation fan speed

In automatic mode, the system uses the most suitable amount of air to reach and maintain the desired comfort level.

You can still adjust the ventilation speed by turning control **1** to increase or reduce the ventilation speed.

Adjusting the air temperature

Turn control **3** to obtain the desired temperature.

Turning the control to the right increases the temperature.

Special note: the highest and lowest settings allow the system to produce maximum hot or cold temperature levels (16.5°C and 25.5°C).



Any action on a button other than the AUTO button triggers deactivation of automatic mode.

"Clear View" function

Press button **2** and the built-in warning light comes on.

This function quickly demists and de-ices the windscreen, the rear screen, the front side windows, and the exteri-

or rear view mirrors (depending on the vehicle). It automatically activates the air conditioning and rear screen de-icing functions.

Press the button **8** to deactivate the heated rear screen: the integrated indicator light goes out.

To exit this function, press button **2** or **4**.



Some buttons have an operating light indicating their operative state.

Adjusting the distribution of air in the passenger compartment

Turn the control **6**. The integrated warning light in the button comes on.



All the air is then directed to the windscreen and front side window demisting vents.



The air flow is distributed between front side window demisting vents, the windscreen demisting vents and the footwells.



The air flow is directed towards the dashboard air vents, the front footwells and, depending on the vehi-

AIR VENTS, HEATING AND AIR CONDITIONING

cle, the second row footwells.



The air flow is mainly directed to the dashboard air vents.



The air flow is directed mainly towards the footwells.

4 Rear screen de-icing and demisting

Press button **8** and the built-in warning light comes on. This function enables rapid demisting or de-icing of the rear screen and de-icing of the rear view mirrors (on equipped vehicles).

To exit this function, press button **8** again. Demisting automatically stops.

Switching the air conditioning on or off

In automatic mode, the system switches the air conditioning system on or off, depending on the climate conditions.

Press the button **5** to force the air conditioning to stop. The built-in indicator light will go out.



Do not open the refrigerant circuit. The fluid may damage eyes or skin.

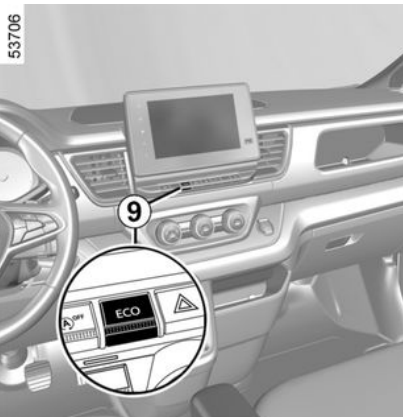

Vehicles equipped with ECO mode (switch 9):
when activated, ECO mode

can reduce the performance of the automatic air conditioning
→ 199.

Air recirculation (isolation of the passenger compartment)

This function is managed automatically but you can also activate it manually. In this case, the operation is confirmed by the illumination of an indicator light on the button **7**.



Using the demisting/de-icing function will disable the air recirculation.

Manual use

Press button **7** and the built-in warning light comes on.

Prolonged use of this position may lead to odours, caused by non-renewal of air, and the formation of condensation on the windows.

To avoid this, air recirculation is disabled automatically after a certain time.

Stopping the system

Turn the control **1** to "OFF" to stop the system. To start it, turn the control **1** again to adjust the blower speed or press button **4**.

AIR VENTS, HEATING AND AIR CONDITIONING



Fuel consumption increases when the air conditioning is being used (switch it off when it is not required).

Additional heating and air conditioning



On equipped vehicles, there are four adjustable air vents and a control console **1**.

These controls only affect the amount of air blown into the passenger compartment:

- one control for hot air (this is blown through the lower vents);

- one control for cold (air comes from upper vents).

Note: avoid closing the four air vents at the same time (risk of damaging the system components).

Vehicle fitted with manual air conditioning

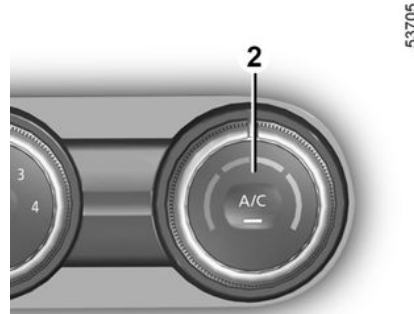

Make sure that the air conditioning is operational (indicator light for button **2** illuminated).

Note: button **2** includes an operation indicator light:

- if the indicator light is on, this indicates that the function is in operation;
- indicator light off, the function is switched off.

AIR VENTS, HEATING AND AIR CONDITIONING

Vehicle fitted with automatic air conditioning



53861

AIR VENTS, HEATING AND AIR CONDITIONING

Controls

Make sure that the air conditioning is operational (indicator light for the A/C OFF button **4** illuminated).

To activate the control console settings **1**, press switch **3**. The indicator light for switch **3** and the indicator light **5** for control **1** are off.

Note: switch **3** and the control console **1** include operation indicator lights:

- if switch **3** and indicator light **5** are illuminated, the control **1** is not activated;
- if switch **3** and indicator light **5** are off, the control **1** is activated.

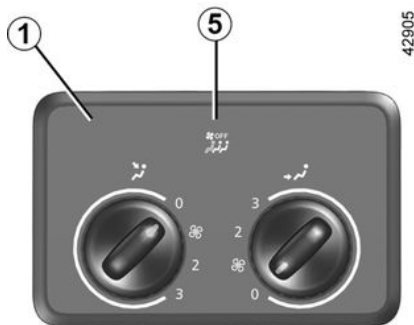

Air conditioning: information and advice on use

Information and advice on use

Advice on use

In some situations (air conditioning off, air recirculation activated, ventilation speed at zero or low etc.), you may notice that condensation starts to form on the windows and windscreen.

If there is condensation, use the "Clear View" function to remove it, then use the air conditioning in automatic mode to stop it forming again.



Vehicles equipped with ECO

Once activated, ECO mode may reduce the performance of the automatic air conditioning
➔ 199.



Do not add anything to the vehicle's ventilation circuit (for example, to remove bad odours).

There is a risk of damage or of fire.

Fuel consumption

You will normally notice an increase in fuel consumption (especially when driving in town) when the air conditioning is operating.

For vehicles fitted with air conditioning with no automatic mode, switch off the system when it is not required.

Advice for reducing consumption and helping to preserve the environment

Drive with the air vents open and the windows closed. If the vehicle has been parked in the sun, open the doors for a few moments to let the hot air escape before starting the engine.

Maintenance

Refer to the maintenance document for your vehicle for the inspection frequency.



Use the air conditioning system regularly, even in cold weather, running it at least once a month for approximately 5 minutes.

AIR VENTS, HEATING AND AIR CONDITIONING

Operating faults

As a general rule, contact your approved dealer in the event of an operating fault.

– **Reduction in de-icing, demisting or air conditioning performance.**

This may be caused by the cabin filter cartridge becoming clogged.

– **No cold air is being produced.**

Check that the controls are set correctly and that the fuses are sound. Otherwise, switch off the system.

Presence of water under the vehicle

After prolonged use of the air conditioning system, it is normal for water to be present under the vehicle. This is caused by condensation.

Refrigerant fluid



Do not open the refrigerant circuit. The fluid may damage eyes or skin.



59952

The refrigerant fluid circuit (of which some components are hermetically sealed) may contain fluorinated greenhouse gases.

Depending on the vehicle, you will find the following information on label **A** affixed inside the engine compartment.

The presence and location of the information on label **A** depends on the vehicle.



Before carrying out any action in the engine compartment, you must switch off the ignition

→ 180.



Type of refrigerant fluid



Type of oil in the air conditioning circuit



Inflammable product



Consult the vehicle user manual



Maintenance

(1) **x.xxx kg** Quantity of refrigerant fluid present in the vehicle.

(2) **GWP xxxxx** Global warming potential.

(3) **CO₂ eq x.xxxt** Quantity in weight and in CO₂ equivalent.

Additional information

Depending on label and depending on the type of refrigerant:

Refrigerant fluid R-134a

- (1) 0.580 kg/0.880 kg
- (2) GWP 1430
- (3) 0.83 t / 1.26 t

Refrigerant fluid R-1234yf

- (1) 0.540 kg/0.850 kg
- (2) GWP 1430
- (3) 0.002 t / 0.003 t

MULTIMEDIA EQUIPMENT

Introduction

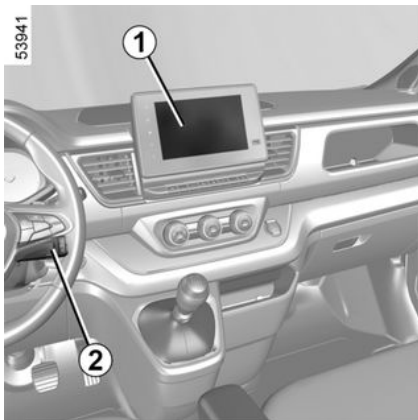

The presence and location of this equipment depends on the vehicle's multimedia equipment.

1. Multimedia touchscreen.
2. Steering column control.
3. Radio.

i Refer to the instructions for this equipment for information on how to operate it.

i Depending on the vehicle, the multimedia touch screen **1** may be protected by film. Do not remove it. In the case of damage, please contact an approved dealer to have it replaced.

Radio 3



Steering column controls 4

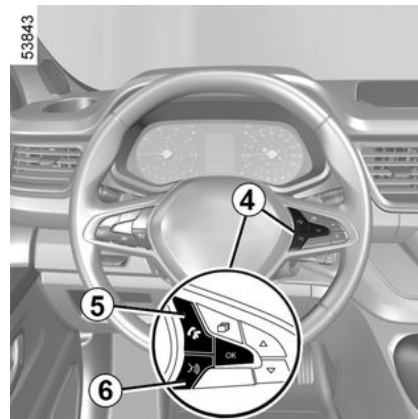

On those vehicles equipped, you can use the hands-free telephone control **5** and voice recognition control **6**.

MULTIMEDIA EQUIPMENT

Microphone 7

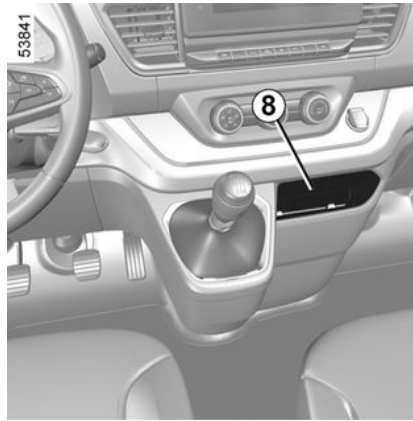

→ 306



Using the telephone

We remind you of the need to conform to the legislation in force concerning the use of such equipment.

Induction charger 8

(depending on the vehicle)

PASSENGER COMPARTMENT EQUIPMENT

Windows



Driver's responsibility

Never leave your vehicle with the card or key inside when there is a child, dependent adult or a pet in it, even for a short while. They may pose a risk to themselves or to others by starting the engine or activating equipment (such as the gear lever or electric windows). If any part of the body becomes trapped, reverse the direction of the window immediately by pressing the relevant switch.

Risk of serious injury.

Electric windows



Avoid resting any objects against a half-open window: there is a risk that the electric window could be damaged.

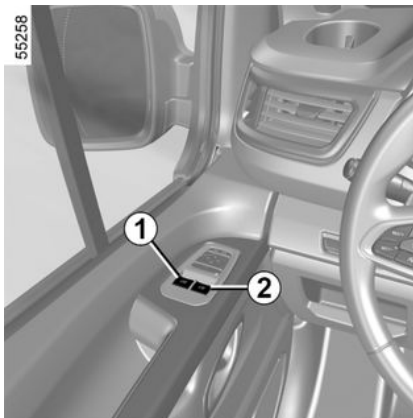

Ignition on:

- press the switch for the window concerned to lower it to the desired height;
- raise the button to raise the window to the desired height.

From the driver's seat

Press the switch:

- **1** for the driver's side;
- **2** for the passenger's side.

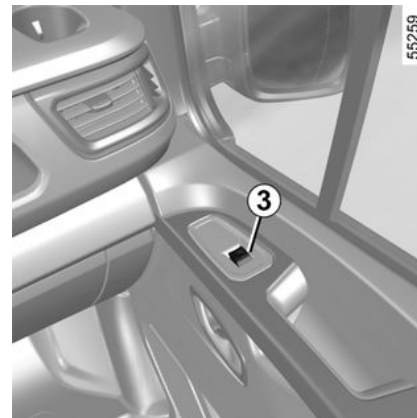

From the front passenger seat

Press the switch **3**.

PASSENGER COMPARTMENT EQUIPMENT

One-touch mode

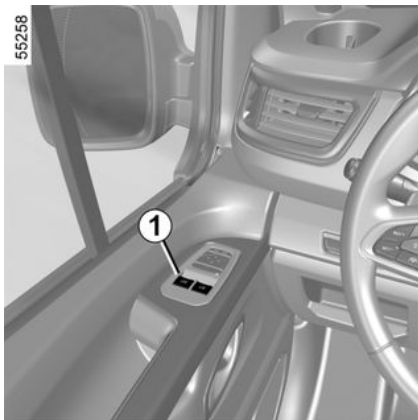

Depending on the vehicle, this mode works in addition to the operation of the electric windows described previously. It is only fitted to the driver's window.

Briefly press or pull the switch **1** as far as it will go: the window will be fully opened or closed. Pressing the switch again stops the window moving.

Impossible to operate the one-touch electric window

The one-touch electric window is equipped with heat protection: if you press the switch for the window more than sixteen consecutive times it goes

into protection mode (the window is locked).

You can:

- use the electric window switch briefly and with intervals of approximately 30 seconds;
- with the engine running, the window will be unlocked after approximately 20 minutes of inaction on the electric window switch.

Note: if the window detects resistance when closing (e.g. by a tree branch, etc.), it stops and then lowers again by a few centimetres.

Operating faults



When closing the windows, ensure that no part of the body (arm, hand, etc.) is protruding from the vehicle.

Risk of serious injury.

In case of a fault when closing a window, the system reverts to normal mode: pull the switch concerned up as often as necessary to fully close the window (the window will close gradually), hold the switch (still on the closure side) for one second then lower and

raise the window fully to reinitialise the system.

If necessary, contact your approved Dealer.

Sliding rear windows



Sliding windows and doors

Before moving them, ensure that no passenger has part of their body outside the window or door.



Move the handle **4** and slide the window to the desired notch.

PASSENGER COMPARTMENT EQUIPMENT

Sun visor

Sun visor

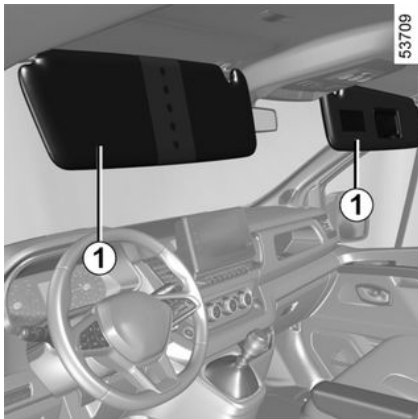

Lower the sun visor **1**.
The sun visor can be swung round against the window.

Wide angle rear view mirror **2**

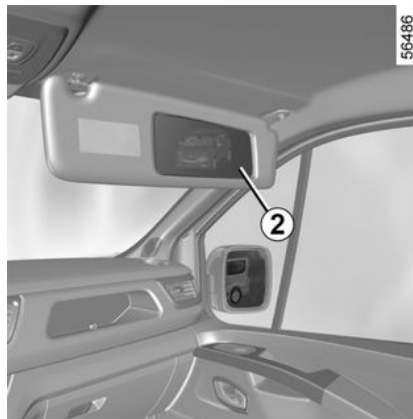

(depending on the vehicle)

Lower the sun visor to access the wide-angle rear view mirror.

Special feature of the wide angle rear view mirror → 158.

Courtesy mirror **3**

(depending on the vehicle)

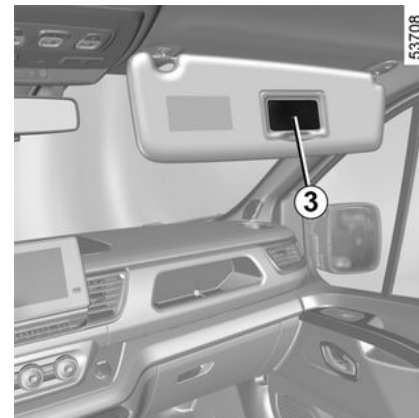

Lower the sun visor to access the courtesy mirror.

Interior lighting

Courtesy lights



When the doors are unlocked and opened, the courtesy and footwell lights come on temporarily.

PASSENGER COMPARTMENT EQUIPMENT



Use switch **1**, **2** or **3** to enable:

- permanent lighting;
- lighting controlled by opening one of the doors. It goes out when the doors concerned are properly closed;
- lighting switches off immediately.

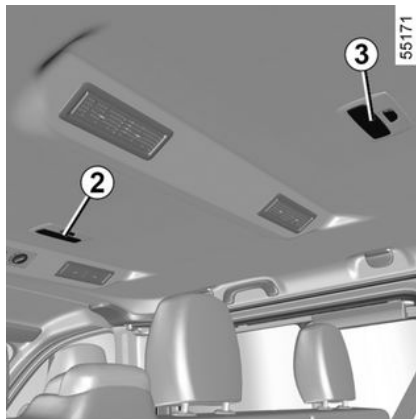

Map reading light

(depending on the vehicle)

Move switch **4**.

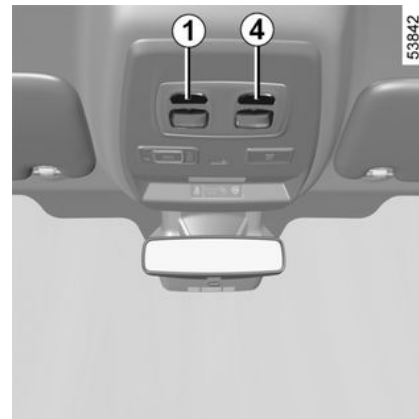

Glovebox light **5**

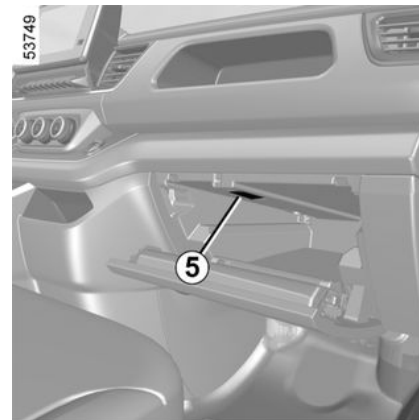

PASSENGER COMPARTMENT EQUIPMENT

This lights up when the glovebox is opened.

Luggage compartment light 6



With the doors properly shut, locking or starting the engine make the interior lights and the courtesy lights go out.



It comes on when the boot is opened.

Light for rear seats 7

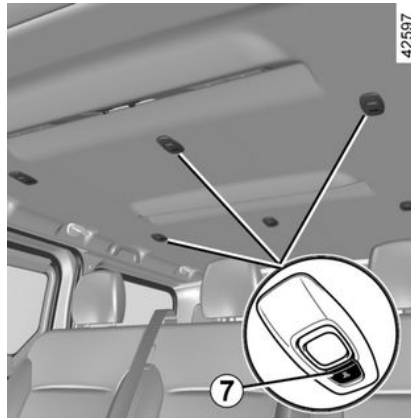

Press switch 7 to enable:

- permanent lighting;
- lighting controlled by opening one of the doors.

Rear light 8

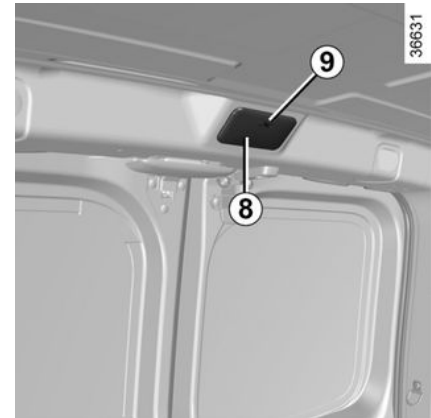

Move the switch 9 to enable:

- permanent lighting;
- intermittent lighting, which comes on when a rear door is opened. The light only goes out when the doors are correctly closed;
- lighting switches off immediately.

Accessories sockets

Accessories sockets

(depending on the vehicle)

PASSENGER COMPARTMENT EQUIPMENT

53712

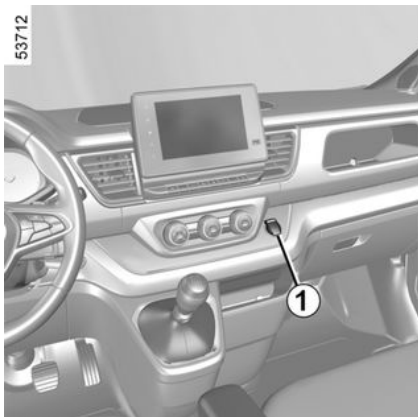

Socket **1** and, depending on the vehicle, sockets **2**, **3** and **4** are designed for connecting accessories which have been approved by our Technical Department and with a power not exceeding 120 Watts (12 V).

56611

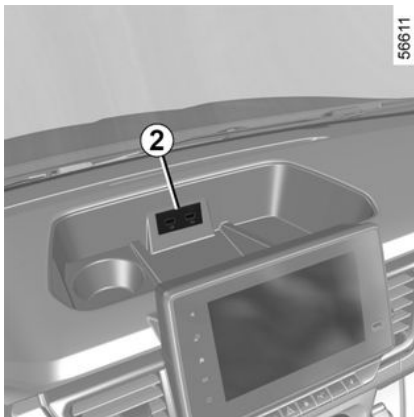

36583

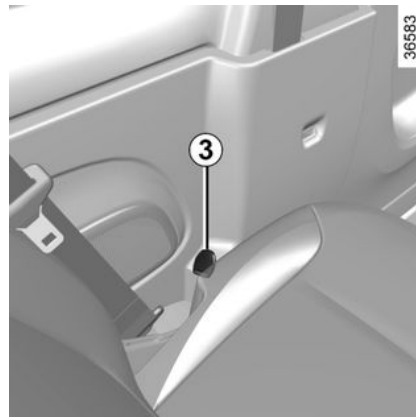

36719

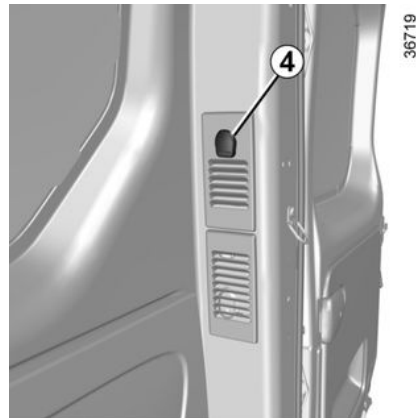

Connect accessories with a maximum power of 120 Watts (12 V) only. When several accessory sockets are used at the same time, the total power of the connected accessories must not exceed 180 watts.
Fire hazard.

PASSENGER COMPARTMENT EQUIPMENT



Before leaving the vehicle, ensure that you **always disconnect all devices** from the accessories sockets to avoid possible malfunctions (discharged battery, locking the opening elements not possible etc.).

Cup holders 5 and 6

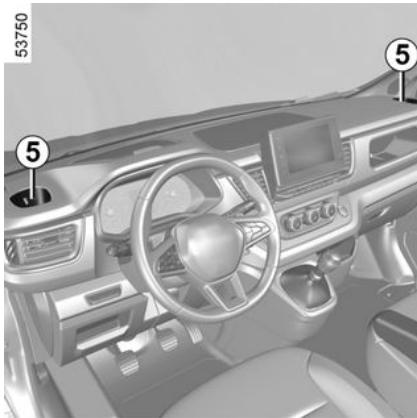

This can be used to store a mobile ashtray, drink cans, etc.

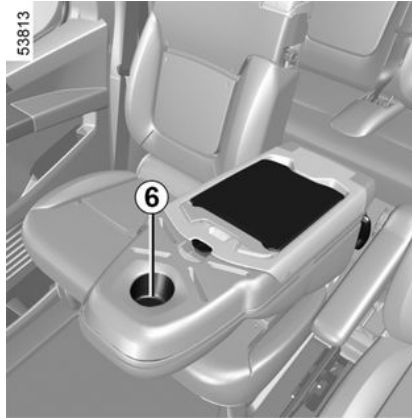

If your vehicle is not fitted with a cigar lighter and an ashtray, these can be obtained from an approved Dealer.

PASSENGER COMPARTMENT STORAGE, FITTINGS

Front storage compartments



Ensure that no hard, heavy or pointed objects are placed in the "open" storage compartments in such a way that they may be projected onto passengers during sudden turning, braking or in the event of an accident.



Nothing should be placed on the floor (area in front of the driver) as these objects may slide under the pedals during sudden braking manoeuvres, thus obstructing their use.

Front door storage compartments 1

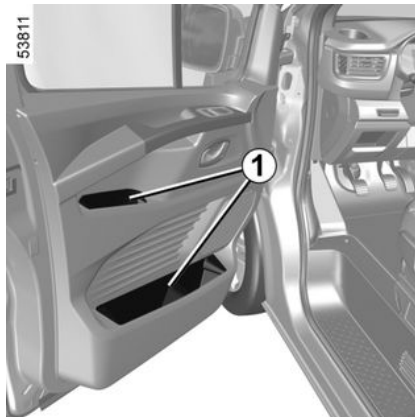

Always close the seat base when driving:
– **there is a risk of injury when braking suddenly or in the event of an accident;**
– **there is a risk of objects being hurled through the passenger compartment.**

Cup holder 2 and storage compartment open 3



This location can be used as a cup holder, a storage compartment or as a receptacle to fit the ashtray.

PASSENGER COMPARTMENT STORAGE, FITTINGS

Passenger cup holder 2



Do not place your card in the storage compartment 2 as it may not be detected.

Right-hand driving position storage compartments 2 and 3

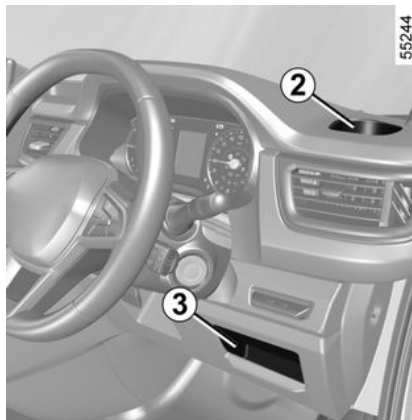

Sun blind storage compartment 4



This can be used for storing motorway tickets, cards, etc.

PASSENGER COMPARTMENT STORAGE, FITTINGS

Centre console storage compartment/Induction charging zone 5

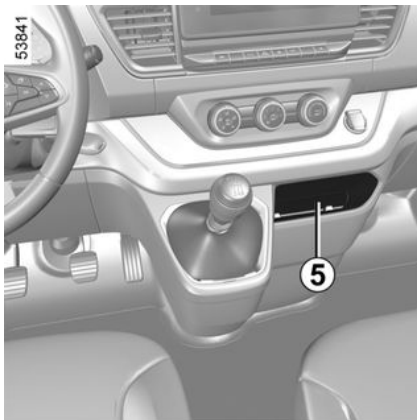

For more information on the induction charging zone, please refer to the multimedia instructions.

When charging a phone in the inductive charging zone, an LED will light up in front of the charging zone. On vehicles equipped with a multimedia system or radio, the charging status is displayed on the screen. Consult the vehicle's multimedia user manual.

 Objects left in the induction charging area **5** may overheat. You are advised to place them in the areas provided for this purpose (storage compartment, sun visor compartment etc.).

 It is essential not to leave any objects (start-up card, USB drive, SD card, credit card, jewellery, keys, coins, etc.) **5** in the induction charging zone when charging your phone. Remove any magnetic cards or credit cards from the phone case before positioning your telephone in the induction charging area **5**.



Using a telephone and/or multimedia tablet

We remind you of the need to conform to the legislation in force concerning the use of such equipment.

Storage compartment 6

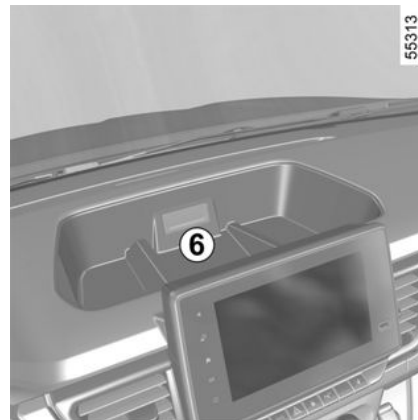

It can hold payment cards, money, A4-sized documents etc.

PASSENGER COMPARTMENT STORAGE, FITTINGS

Radio location 7



Dashboard storage compartment 8 and 9

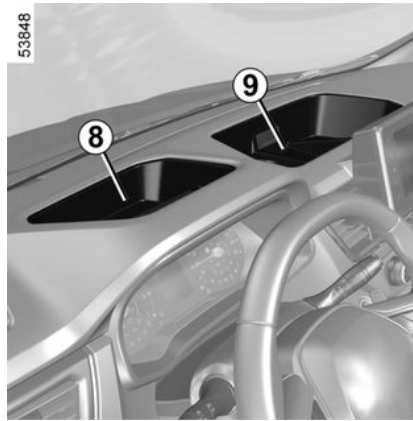

Dashboard storage compartment 10

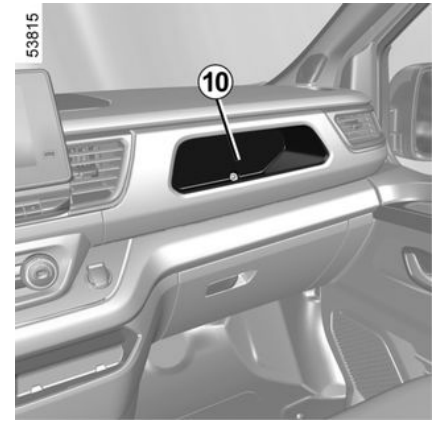

PASSENGER COMPARTMENT STORAGE, FITTINGS

Dashboard passenger storage compartment 11 and 12

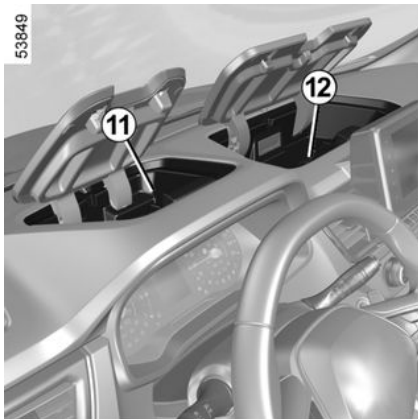

Additional storage compartments



Ensure that no hard, heavy or pointed objects are placed in the "open" storage compartments in such a way that they may be projected onto passengers during sudden turning, braking or in the event of an accident.

Glovebox 1

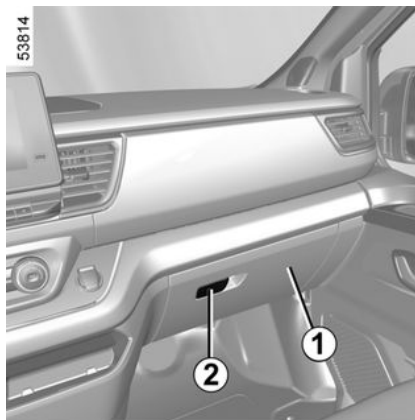

To open, pull control 2.

Depending on the vehicle, the glove box may have ventilation and air conditioning (one 1.5 litre bottle can be stored there).



Maximum weight allowed in the glovebox 1: 4 kg evenly distributed.

Right-hand driving position glovebox

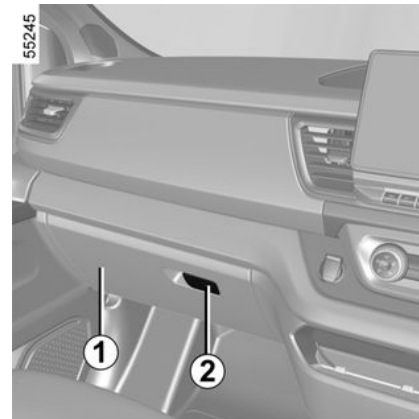

PASSENGER COMPARTMENT STORAGE, FITTINGS

Passenger storage drawer 3

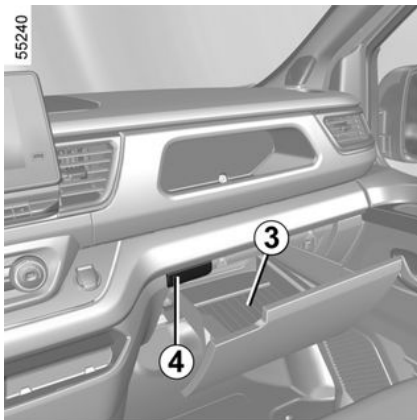

To open, press control 4.

Depending on the vehicle, the glove box may have ventilation and air conditioning (one 1.5 litre bottle can be stored there).



Maximum permitted load in the storage drawer 3: 4 kg, evenly distributed.

Storage compartment 5 under the front seat base

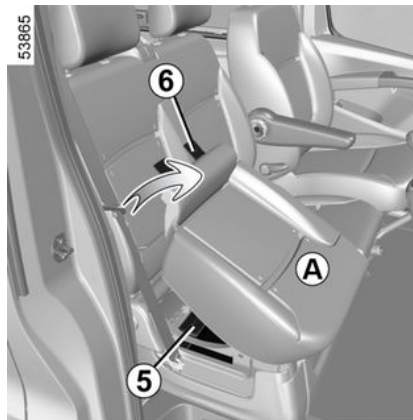

To access this, pull the tabs 6 and tilt the seat base A forwards.

Seatback in table position

(van version only)

For further information, please refer to the → 54 section.

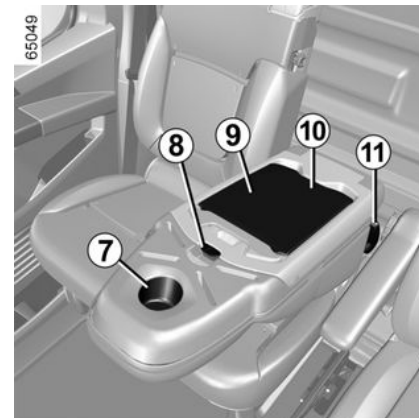

On equipped vehicles, fold down the centre seatback by lifting the control 11. On the back of the centre seat you will find:

- a cup holder 7;
- a storage area 9;
- a shelf 10.



It is forbidden to sit in the centre seat if its seatback is folded down.

Storage compartment 9

(van version only)

For further information, please refer to the → 54 section.

PASSENGER COMPARTMENT STORAGE, FITTINGS

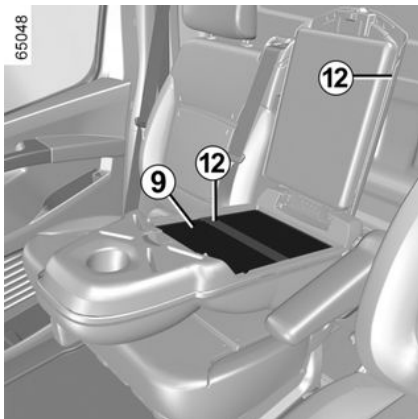

To open, press control **8**.

Inside, the strap **12** can be used to keep an object in place.

With the storage compartment **9** closed, the opening **12** allows you to leave a charging cable connected to an accessories socket.

Shelf **10**

(van version only)

For further information, please refer to the ➔ **54** section.

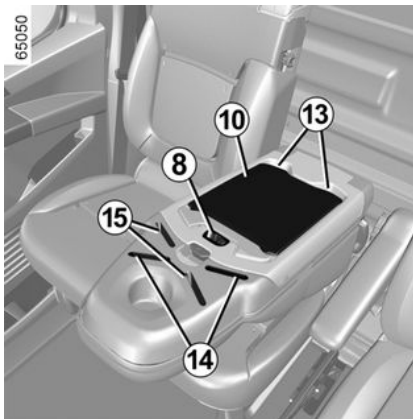

To unlock the shelf, press control **8**.

To fit the shelf, insert the end pieces **13** of the shelf into slot **14** or **15**.



Ensure that no hard, heavy or pointed objects are placed in the open storage compartments in such a way that they may fall on any passengers during sudden turning, braking or in the event of an accident.

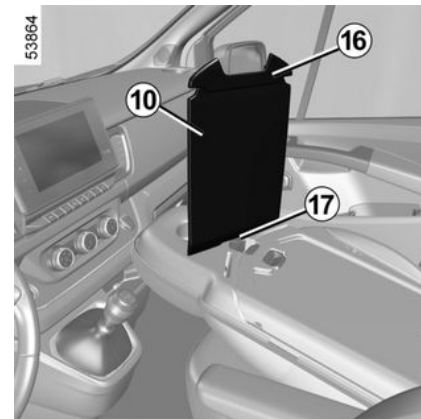

You can attach using the document clamp **16**.

To remove the shelf, press the control **17**.

Note: make sure to close the shelf and remove any item from the cup holder before raising the centre seatback. Check that the back of the centre seat is properly locked.

PASSENGER COMPARTMENT STORAGE, FITTINGS

Rear storage compartments



Ensure that no hard, heavy or pointed objects are placed in the "open" storage compartments in such a way that they may be projected onto passengers during sudden turning, braking or in the event of an accident.



When turning corners, accelerating or braking, ensure that the receptacle being held by the cup holder is not dislodged.

There is a risk of burning if hot liquid escapes.



Do not use the grab handle **2** to get in or out of the vehicle.

Rear seat storage pockets 1

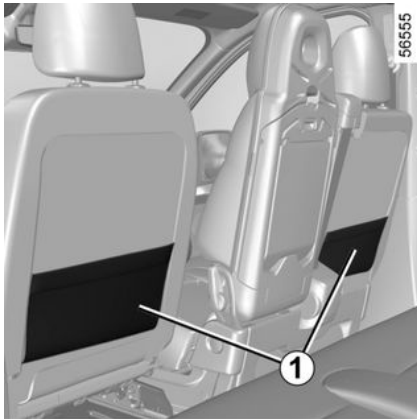

Grab handle 2



This offers support and can be held when the vehicle is moving.

Clothes hooks 3

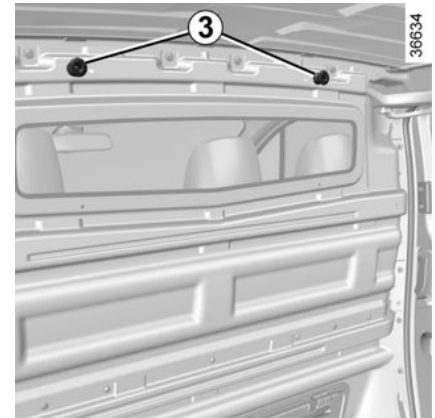

Depending on the vehicle, hooks may be placed in the partition in the loading space.

For safety reasons, this hook may only be used to hang clothes.

PASSENGER COMPARTMENT STORAGE, FITTINGS

Rear load area upper storage compartment 4



Reserved for the transport of objects only.

The total weight of the rear load area storage compartment must not exceed 35 kg, evenly distributed.



Do not hang any heavy and/or sharp objects which may fall while you are driving.

Risk of injury.

Recess 5 and flap 7

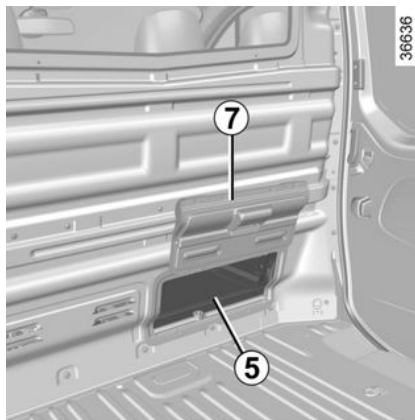

Depending on the length of the objects being transported in the rear load area, you can use recess 5.

Open the flap 7 held in place by magnets.

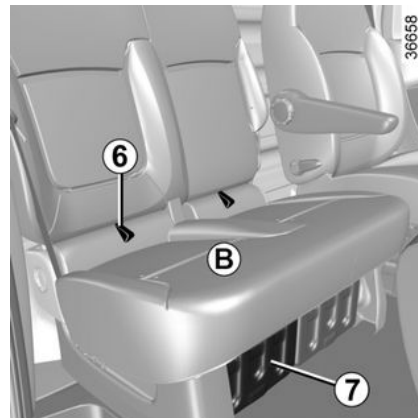

Use the flap 7 to extend the load length:

- pull the tab 6 to raise the seat belt B;
- move the flap 7 towards the interior of the seat by pulling the tab 8.



It is prohibited to use front side passenger seat while the flap 7 is open.

Risk of serious injury when braking sharply or in an impact.

PASSENGER COMPARTMENT STORAGE, FITTINGS

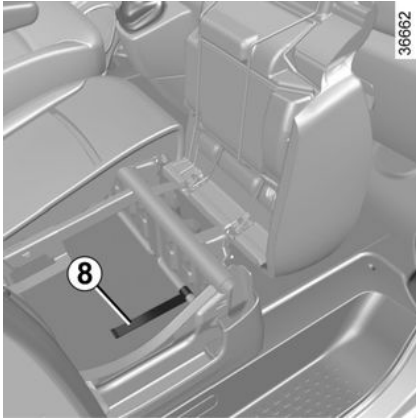

Ensure that no hard, heavy or pointed objects are placed in the "open" storage compartments in such a way that they may be projected onto passengers during sudden turning, braking or in the event of an accident.

TRANSPORTING OBJECTS

Transporting objects



For your safety, check that all the vehicle's doors are properly closed before starting the engine.



While driving with the right rear hinged door open, always secure transported loads.

The left-hand door, which remains shut, should not be used to hold transported loads in place. Using the right rear hinged door open while driving should only be done in exceptional cases.

In any event, please refer to local legislation.

Risk of loads falling on the road surface.



Always position the heaviest items directly on the floor.

Use the lashing points on the luggage compartment floor, if these are fitted to the vehicle. The load should be loaded in such a way that no items will be thrown forward and strike the occupants if the driver has to brake suddenly or while driving on a steep gradient. Fasten the rear seat belts, even if the seats are not occupied.

Transporting objects in the rear load area

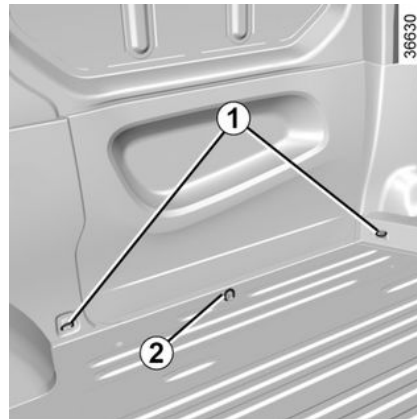

Depending on the vehicle, securing rings **1** and **2** can be used to stop transported objects from moving. The number of rings and their locations may vary depending on the vehicle.



The sole purpose of these rings **1** is to prevent transported objects from moving. The objects must be secured to the mounting rings **2** on the vehicle floor beforehand.

TRANSPORTING OBJECTS

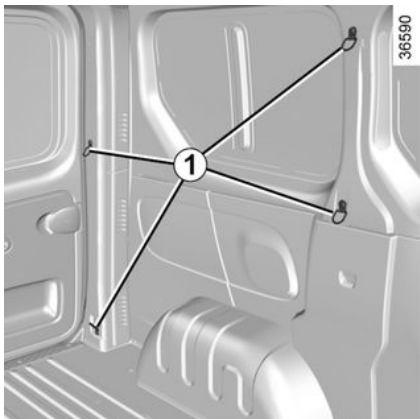

Ensure that the objects being transported are evenly distributed throughout the loading area.

Special note for van version

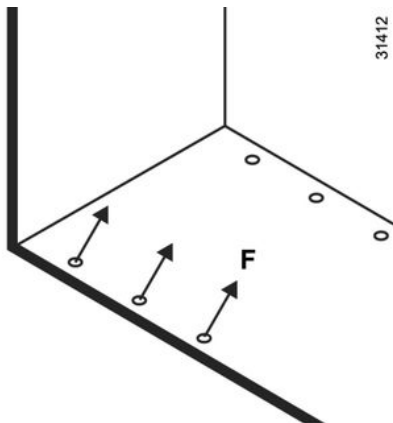

F max: 400 daN

Luggage cover



Do not place any objects, especially heavy or solid objects on the luggage cover. These may pose a risk to the vehicle occupants if the driver has to brake suddenly or if the vehicle is involved in an accident.

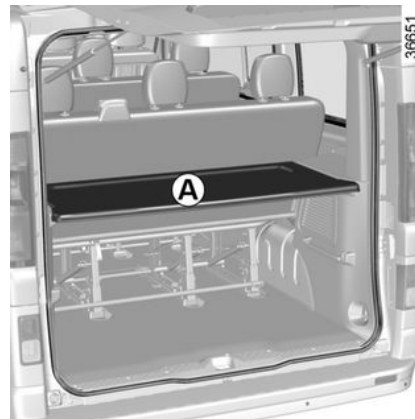

The luggage cover is made up of one or two rigid sections.

There are two possible positions:

- the upper position **A**;
- the lower position **B**.

Depending on the vehicle, you can lift section **1** to a vertical position to make loading easier.

TRANSPORTING OBJECTS

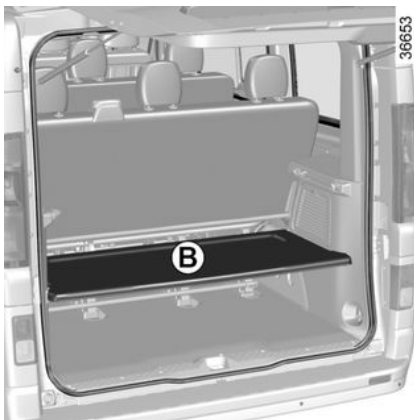
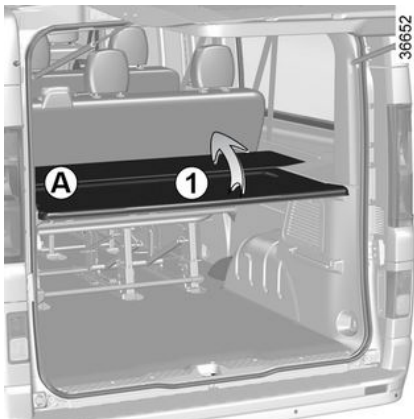

Luggage net



Make sure that the rod end **1** is supported by the metal part and not the plastic part of the cover.

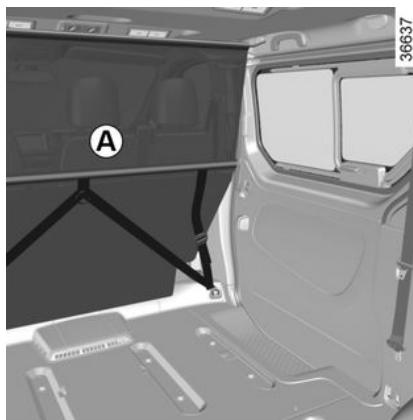

On equipped vehicles, the luggage net **A** can be used, when transporting animals or luggage, to separate them from the passenger section.

It can be positioned:

- behind the front seats;
- behind a rear bench seat.

Fitting the luggage net behind the front seats

Inside the vehicle, on each side:

Upper mounting:

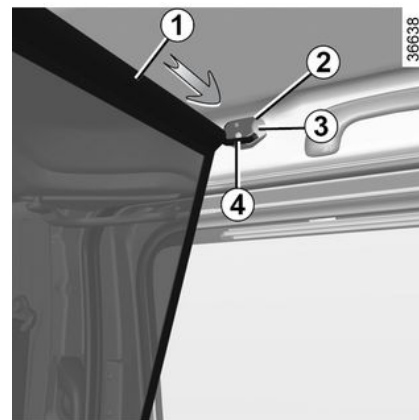

- lift and hold the cover **2** using a flat-blade screwdriver to access the mounting hole;
- fully insert the upper rod **1** of the net into the largest section **3** of the hole;
- slide the rod into the lower section **4** of the hole.

TRANSPORTING OBJECTS

Lower mounting:

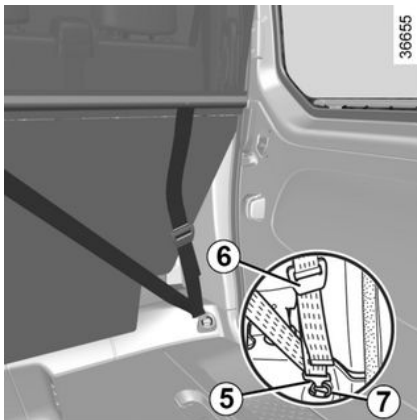

- attach the net strap hook **5** onto the ring **7** at the base of the bench seat;
- adjust the net strap so that it is taut.

Removal

Loosen the strap by lifting the adjustment device **6** upwards. Detach the belts.

Fitting the luggage net *A* behind the rear seats



Make sure that the rod end **1** is supported by the metal part and not the plastic part of the cover.

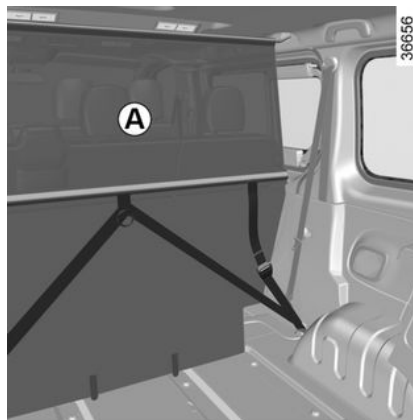

Inside the vehicle, on each side:

Upper mounting:

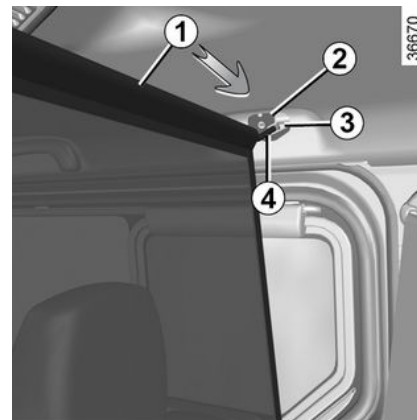

- lift and hold the cover **2** using a flat-blade screwdriver to access the mounting hole;
- fully insert the upper rod **1** of the net into the largest section **3** of the hole;
- slide the rod into the lower section **4** of the hole.

TRANSPORTING OBJECTS

Lower mounting:

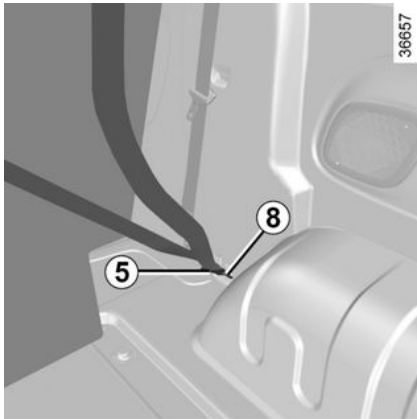

- attach the net strap hook **5** onto the ring **8**;
- adjust the net strap so that it is taut.

Removal

Loosen the strap. Detach the belts.

Towbar

Fitting towing equipment

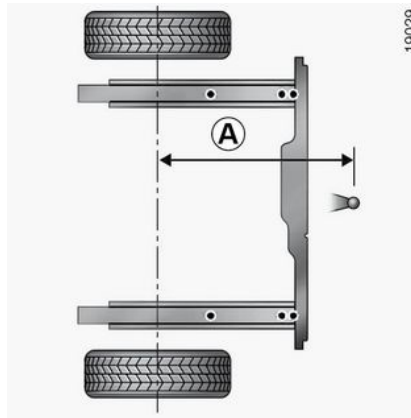

A: 1,093 mm

Fitting the towbar coupling ball

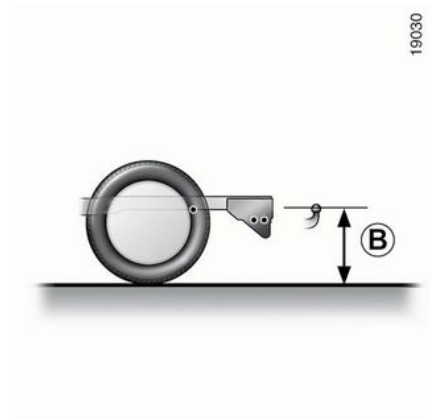

Position the ball within the range of bolt **1** or **2** to abide by a height **B** between 350 and 420 mm, with the vehicle loaded (use the example in the illustration above).

To assemble the towbar ball, please consult the equipment assembly instructions.

TRANSPORTING OBJECTS

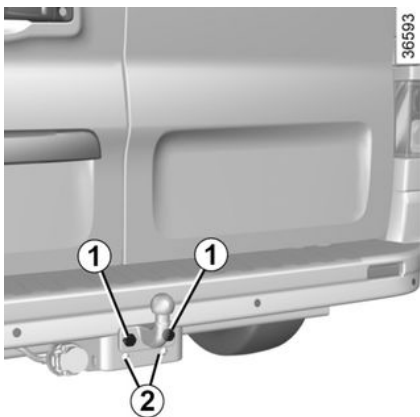

Special note related to connecting/disconnecting a trailer to/from the towing system

Each time a trailer or caravan is connected for the first time, when it is disconnected from the towing system or when replacing a faulty bulb on your vehicle → 353, your vehicle's lighting must be synchronised with your trailer or caravan lighting.

To do this:

- switch off all of the lights on your vehicle (interior and exterior);
- switch off the ignition;
- get out of your vehicle, then lock all the doors using the key or the "hands-free" card → 34, → 20 ;

– wait approximately 5 minutes before accessing your vehicle again.

Before driving, check the lighting functions.

Note: when connecting/disconnecting the trailer with the lights on, the trailer lights may flash.



Permissible nose weight, maximum permissible towing weight with or without braking → 382.

Choice and fitting of towing equipment

Maximum weight of towing equipment:

- Towbar (*cross member and hitch*) originally fitted to the vehicle: the tow ball (*fixed/retractable/removable*) must not exceed **9.5 kg**;
- Towbar (*cross member and hitch*) not originally fitted to the vehicle: the entire towbar and mountings must not exceed **31.5 kg**.

Any towing device must not obstruct any lighting component or the number plate when not in use. In all cases, you must comply with the regulations of the particular country you are in.

For fitting and conditions of use, refer to the equipment fitting instructions. Please keep these instructions with the rest of the vehicle documentation.

TRANSPORTING OBJECTS

Roof bars



If original roof bars, approved by our Technical Department, are supplied with screws, only use these screws for attaching the roof bars to the vehicle.

accessories (bicycle rack, roof box, etc.) fitted on the roof bars: these must be correctly positioned and secured, and must not prevent the luggage compartment door from operating correctly.



For information on the range of equipment adapted to your vehicle, we advise you to consult an approved Dealer.

Please refer to the manufacturer's instructions on how to fit and use the bars.

Please keep these instructions with the rest of the vehicle documentation.

Maximum permissible load on roof rack → 382.

Accessing the mounting points 1

53944

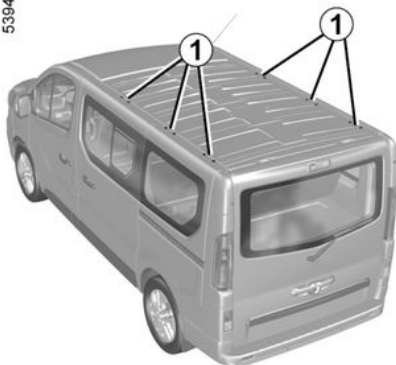

User precautions

Handling the tailgate

Before operating the luggage compartment door, check the objects and/or

ACCESSING THE ENGINE, LEVELS

Bonnet



Before carrying out any action in the engine compartment, you must switch off the ignition

→ 180.



Please note when working close to the engine that it may be hot. The engine cooling fan may also start at any moment. The



label in the engine compartment reminds you of this.

Risk of injury.



When working in the engine compartment, ensure that the windscreen wiper stalk is in the park position.

Risk of injury.



Avoid placing any pressure on the engine bonnet: risk of the bonnet closing by accident.



In the event of even a slight impact involving the radiator grille or bonnet, have the bonnet lock checked by an approved dealer as soon as possible.



After any procedure in the engine compartment, make sure that you do not forget anything (cloth, tools, etc.). Otherwise, this may lead to engine damage or cause a fire.

Unlocking the bonnet catch

To open, pull the handle **1**.

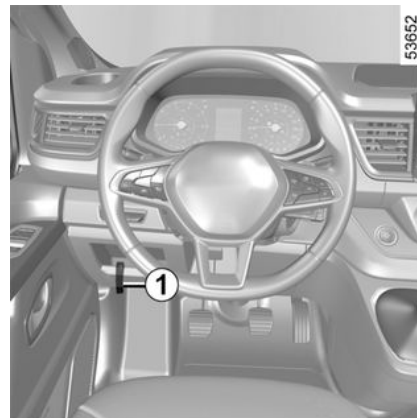

53652

5

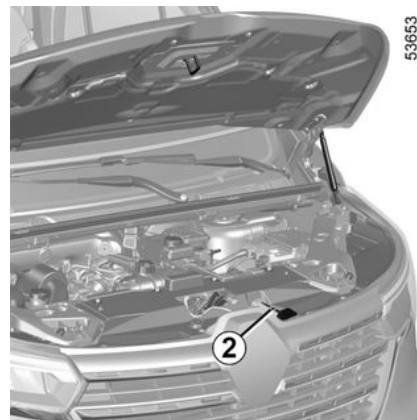

53653

To unlock, push the tab **2** to the left as you open the bonnet.

ACCESSING THE ENGINE, LEVELS

Opening the bonnet

Lift the bonnet, helping it up, and it will rest in position with the help of struts.

Closing the bonnet

Check that nothing has been left in the engine compartment.

To close the bonnet again, hold the bonnet in the middle and lower it to 30 cm above the closed position, then release it. It will latch automatically under its own weight.



Ensure that the bonnet is properly locked. Check that nothing is preventing the catch from locking (gravel, cloth, etc.).

Engine oil

General information



Before carrying out any action in the engine compartment, you must switch off the ignition

→ 180.

It is normal for an engine to use oil for lubrication and cooling of moving parts and it is normal to top up the level between oil changes.

However, contact your approved Dealer if more than 0.11 gal (0.5 litre) is being consumed every 600 miles (1,000 km) after the running in period.

Oil change frequency: check the oil level from time to time and certainly before any long journey to avoid the risk of damaging your engine.



Adding engine oil

Use a funnel or protect the filling neck area to avoid engine oil escaping onto a hot part of the engine compartment or a sensitive part (e.g. electrical components).

Fire hazard.

Reading the oil level



Exceeding the maximum engine oil level

Under no circumstances should the maximum filling level **B** be exceeded: this could damage the engine and the emission control system. If the level exceeds the "MAXI" level, **do not start your vehicle** and contact an authorised dealer.

29990

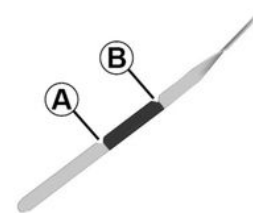

The oil level should be read with the vehicle on level ground, after the en-

ACCESSING THE ENGINE, LEVELS

gine has been switched off for some time.

The dipstick must be used to read the exact oil level and make sure that the maximum level has not been exceeded (risk of engine damage).

Depending on the vehicle, the instrument panel display only alerts the driver when the oil level is at its minimum.

- remove the dipstick and wipe with a clean, lint-free cloth;
- push the dipstick in as far as it will go;
- remove the dipstick again;
- read the level: it should never fall below the "MINI" level **A** nor exceed the "MAXI" level **B**.

Once the level has been read, push the dipstick in as far as it will go.

Topping up, filling, draining



Please note when working close to the engine that it may be hot. The engine cooling fan may also start at any moment. The



label in the engine compartment reminds you of this.

Risk of injury.



Filling and/or checking the oil level: when topping up or checking the oil level, ensure that no oil leaks onto the engine components.

Do not forget to properly close the cap and refit the dipstick to prevent any oil spatter on hot engine components.

Fire hazard.



Before carrying out any action in the engine compartment, you must switch off the ignition

→ 180.



Engine oil change: if you are changing the oil when the engine is hot, be careful not to scald yourself as the oil drains.



Never run the engine in an enclosed space as exhaust gases are poisonous.



When working in the engine compartment, ensure that the windscreen wiper stalk is in the park position.

Risk of injury.

ACCESSING THE ENGINE, LEVELS



Adding engine oil

Use a funnel or protect the filling neck area to avoid engine oil escaping onto a hot part of the engine compartment or a sensitive part (e.g. electrical components).

Fire hazard.



Exceeding the maximum engine oil level

Under no circumstances should the maximum filling level be exceeded: this could damage the engine and the emission control system.

If the oil level exceeds the maximum level, **do not start your vehicle** and contact an approved dealer.

Topping up/filling

The vehicle must be parked on level ground and the engine should be stopped and cold (for instance, before the engine is started up for the first time in the day).



If there is an abnormal or repeated drop in the fluid level, consult an approved dealer.



Do not exceed the "MAXI" level and remember to refit the cap **1** and the dipstick **2**.

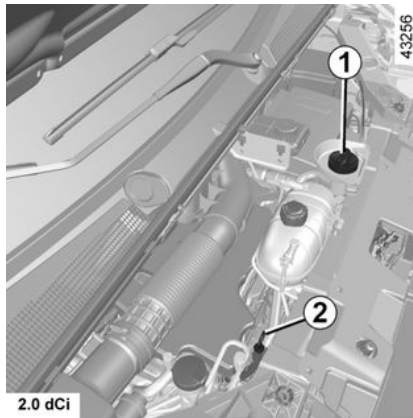

- Loosen the cap **1**;
- top up the level (as a guide, the capacity between the "MINI" and the "MAXI" mark on the dipstick **2** is be-

tween 0.33 and 0.44 gallons (1.5 and 2 litres) depending on the engine);

- wait for approximately 10 minutes to allow the oil to flow;
- check the level using the dipstick **2** (as described previously).

Once the level has been read, insert the dipstick **2** as far as it will go and, depending on the vehicle, turn it a quarter of a turn to lock it. Fully tighten the cap **1**.

Oil change

Service interval: refer to the maintenance document for your vehicle.

Oil change capacity

Please refer to the maintenance document for your vehicle, or contact an authorised dealer.

Always check the engine oil level using the dipstick, as explained previously (it should never fall below the "MINI" mark nor exceed the "MAXI" mark on the dipstick).

Engine oil grade

Refer to the maintenance document for your vehicle.

Level Coolant



ACCESSING THE ENGINE, LEVELS

This picture can be seen on the coolant reservoir cap **2**.

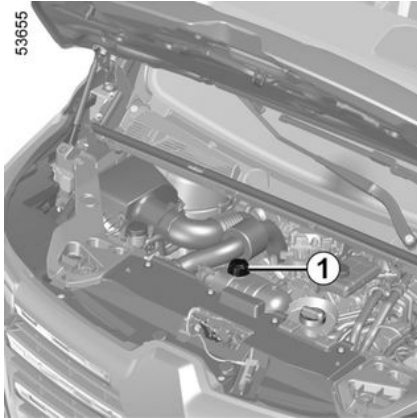

With the ignition switched off and the vehicle parked on flat ground, the level **when cold** must be between the "MINI" and "MAXI" marks indicated on the coolant reservoir **1**.

Top this level up **when cold** before it reaches the "MINI" mark.



If there is an abnormal or repeated drop in the fluid level, consult an approved dealer.

Frequency of checking coolant level

Check the coolant level regularly (very severe damage is likely to be caused to the engine if it runs out of coolant).

If the level needs to be topped up, only use products approved by our Technical Department which ensure:

- antifreeze protection;
- anti-corrosion protection of the cooling system.

Replacement intervals

Refer to the maintenance document for your vehicle.

Levels, filters



Before carrying out any action in the engine compartment, you must switch off the ignition

→ 180.



Please note when working close to the engine that it may be hot. The engine cooling fan may also start at any moment. The



label in the engine compartment reminds you of this.

Risk of injury.



When working in the engine compartment, ensure that the windscreen wiper stalk is in the park position.

Risk of injury.



No operations should be carried out on the cooling circuit when the engine is hot.

Risk of burns.

Brake fluid level



ACCESSING THE ENGINE, LEVELS

This should be checked frequently, and immediately if you notice even the slightest loss in braking efficiency. The level should be read with the engine switched off and on level ground.

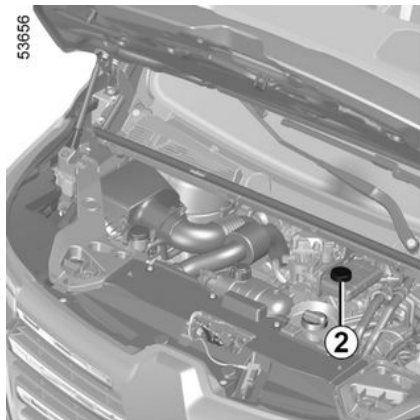

Level 2

It is normal for the level to drop as the brake shoes become worn, but it must never drop lower than the "MINI" warning line.

If you wish to check the disc and drum wear yourself, you should obtain the document explaining the checking procedure from our network or from the manufacturer's website.

Topping up

After any operation on the hydraulic circuit, a specialist must replace the fluid.

Only use fluids approved by our Technical Department (and taken from a sealed container).

Replacement intervals

Refer to the maintenance document for your vehicle.



If there is an abnormal or repeated drop in the fluid level, consult an approved dealer.

Windscreen washer reservoir



This picture can be seen on the window washer reservoir cap **3**.

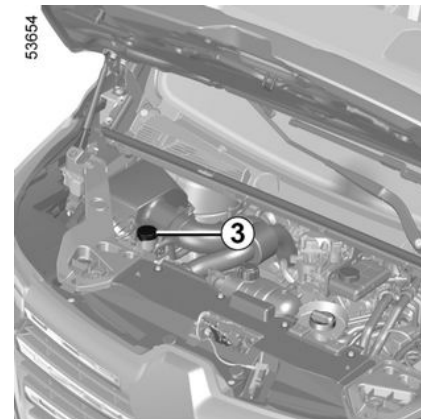

Topping up

With the engine off, open the cap **3**. Fill until you can see the fluid, then refit the cap.

Fluid

Only use windscreen washer fluid containing antifreeze. We advise you to consult an approved dealer or a qualified professional.

Note: do not use hard water (risk of damage to the priming pump, limescale building up on the pump and the jets).

ACCESSING THE ENGINE, LEVELS

Filters

The replacement of filter elements (air filter, cabin filter, diesel filter etc.) is scheduled in the maintenance operations for your vehicle.

Replacement intervals for filter components: refer to the maintenance document for your vehicle.

BATTERY



Before carrying out any action in the engine compartment, you must switch off the ignition

→ 180.



Please note when working close to the engine that it may be hot. The engine cooling fan may also start at any moment. The



label in the engine compartment reminds you of this.

Risk of injury.

Replacing the battery



For your own safety and to ensure correct operation of the vehicle's electrical equipment (lights, windscreen wipers, ABS etc.), it is essential that any operation on the battery (removal, disconnection etc.) is performed by a specialist professional.

Risk of serious burns or electric shocks.

You must respect the replacement intervals (without exceeding them) as stated in the maintenance document.

The battery is a specific type. Please ensure it is replaced with the same type. Call an approved dealer.

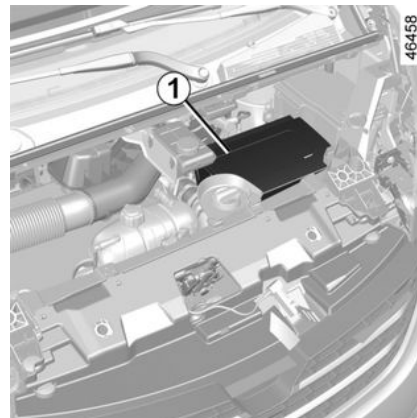

This is located under the cover **1** and does not need to be serviced. **You should not open it or add any fluid.**

When the ignition is off, some consumers may also be switched off (dipped beam headlights, radio, ventilation, interior lighting etc.). When the level is extremely low, the "Battery Low Start Engine" message is displayed.

The charge status of the battery can decrease, especially if you use your vehicle:

- for short trips;
- in an urban setting;
- when the temperature is low;
- with the vehicle stationary and the engine off.

BATTERY

Label A

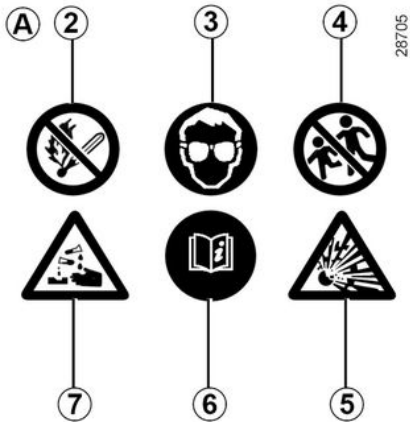

Observe the indications on the battery:

- **2** naked flames and smoking are prohibited;
- **3** eye protection compulsory;
- **4** keep away from children;
- **5** explosive material;
- **6** refer to the manual;
- **7** corrosive materials.

CLEANING

Bodywork maintenance

A well-maintained vehicle will last longer. It is therefore recommended to maintain the exterior of the vehicle regularly.

Your vehicle has been treated with very effective anti-corrosion products. It is nevertheless subject to various outside influences.

5 Corrosive agents in the atmosphere:

- Atmospheric pollution (in built-up and industrial areas);
- saline atmospheres (near the sea, particularly in hot weather);
- seasonal and damp climatic conditions, (e.g.: road salt in winter, water from road cleaners, etc.).

Minor impacts

Abrasive action:

Dust and sand in the air, mud, road grit thrown up by other vehicles, etc.

You should take a number of minor precautions in order to safeguard your vehicle against such risks.

You should do the following

Wash your car frequently, **with the engine off**, with cleaning products rec-

ommended by our Technical Department (never use abrasive products). Rinse thoroughly beforehand using a jet washer:

- spots of tree resin and industrial pollution;
- mud in the wheel arches and underneath the body which forms damp patches;
- **bird droppings, which cause a chemical reaction with the paint that rapidly discolours paintwork and may even cause the paint to peel off;**

Wash the vehicle **immediately** to remove these marks as it is impossible to remove them by polishing;

- salt, particularly in the wheel arches and underneath the body after driving in areas where the roads have been gritted.

Remove any plant matter (resin, leaves, etc.) from the vehicle regularly.

Observe local regulations about washing vehicles (e.g. do not wash your vehicle on a public highway).

Observe the vehicle stopping distances when driving on gravelled surfaces to prevent paint damage.

Repair, or have repaired quickly, areas where the paint has been damaged, to prevent corrosion spreading.

Remember to visit the body shop periodically in order to maintain your anti-corrosion warranty. Refer to the maintenance document.

If washing the vehicle with a high-pressure cleaning device, please take the following precautions:

- make sure that your vehicle's paintwork, the area or the component that you want to clean is compatible with this type of washing;
- the pressure delivered by the device must be less than 100 bar;
- when washing, position the spray nozzle at least 15 cm from the vehicle and check that the water flow rate is less than 3.30 gal (15 l) per minute;
- do not persist in washing the same area, impacted points or the seals (risk of damage to the paint, seals becoming detached, etc.).

If mechanical components, hinges, etc. have been cleaned, they must be protected again by spraying with products approved by our Technical Department.



We have selected special products to care for your vehicle and you can obtain these from the manufacturer's accessory outlets.

CLEANING

Do not do the following

Wash the vehicle in bright sunlight or freezing temperatures.

Do not scrape off mud or dirt without pre-wetting.

Allow dirt to accumulate on the exterior.

Allow rust to form following minor impacts.

Use solvents not approved by our Technical Department to remove stains as they could damage the paintwork.

Do not drive in snow or muddy conditions without washing the vehicle, particularly under the wheel arches and body.



Degrease or clean using high-pressure cleaning equipment or by spraying products not approved by our Technical Department:

- mechanical components (e.g. engine compartment);
- wheels (e.g. braking system components such as brake callipers);
- underbody;
- parts with hinges (e.g. inside the doors);
- painted plastic external fittings (e.g. bumpers).

Doing this could give rise to corrosion or operational faults.

Vehicles with a matte paint finish

This type of paint requires certain precautions.

You should do the following

Wash the vehicle by hand using plenty of water, using a soft cloth or a gentle sponge.

Do not do the following



Use wax-based products (polishing).

Rub too hard.

Wash the vehicle in a roller-type car wash.

Attach stickers to the paintwork (risk of leaving marks).

Wash the vehicle using a high-pressure cleaning device.

Using a roller type car wash

Return the wiper stalk to the Park position ➔ 167 . Check the mounting of external accessories, additional lights and rear view mirrors, and ensure that

the wiper blades are secured with adhesive tape.

Remove the radio aerial mast if your vehicle is fitted with this equipment.

Remember to remove the tape and re-fit the antenna after washing.

Cleaning the headlights, sensors and cameras

Use a soft cloth or cotton wool. If this does not clean them properly, moisten the cloth with soapy water, then wipe clean with a soft damp cloth or cotton wool.

Finally, carefully dry off with a soft dry cloth.

Do not use cleaning products containing alcohol or utensils (e.g. a scraper).

Cleaning stickers, decorative films, etc.

You should do the following

Use a soft cloth or cotton wool. Moisten it with soapy water, then always wipe clean with a soft cloth or cotton wool.

Finally, carefully dry off with a soft dry cloth.

CLEANING

Do not do the following



Use alcohol-based cleaning products. Use utensils (e.g. a scraper). Rub too hard.

Wash the area using a high-pressure cleaning device.

Interior trim maintenance

A well-maintained vehicle will last longer. It is therefore recommended to maintain the interior of the vehicle regularly.

A stain should always be dealt with swiftly.

Whatever the type of stain, use **cold (or tepid) soapy water prepared with natural soap**.

Detergents (washing-up liquid, powdered products, alcohol-based products) should not be used.

Use a soft cloth.

Rinse and wipe up excess water.

Multimedia screen

Maintenance of the screen may depend on the type of multimedia equipment. Please refer to the multimedia instructions for further information.

Glass instrument panel

(e.g. instrument panel, clock, exterior temperature display, radio display, etc.)

Use a soft cloth or cotton wool.

If this does not clean them properly, use a soft cloth (or cotton wool) slightly moistened with soapy water and then wipe clean with another soft damp cloth or cotton wool.

Finally, **carefully** dry off with a soft dry cloth.

Do not use products containing alcohol and/or spray fluids on the area.

Seat belts

These must be kept clean.

Use products selected by our Technical Department (approved outlets) or warm, soapy water and a sponge and wipe with a dry cloth.

Detergents or dyes must not be used under any circumstances.

Textiles (seats, door trim, etc)

Vacuum-clean the textiles **regularly**.

Liquid stain

Use soapy water.

Dab lightly (never rub) with a soft cloth, rinse and remove the excess.

Solid or pasty stain

Carefully remove the excess solid or pasty material **immediately** using a spatula (working from the edges to the centre to avoid spreading the stain).

In the case of a liquid stain, clean as indicated.

Special instructions for sweets or chewing gum

Place an ice cube on the stain to solidify it then proceed as for a solid stain.



For further recommendations for maintaining the interior, and/or for any unsatisfactory results, please see an authorised dealer.

Removal/replacing removable equipment originally fitted in the vehicle

If you need to remove equipment in order to clean the passenger compartment (for example, mats), always ensure that they are correctly refitted and are the right way around (the driver's mat should be fitted on the driver's side etc.) and fit them with the components supplied with the equipment (for example, the driver mat should always

CLEANING

be fixed using the pre-fitted mounting components).

With the vehicle stationary, always ensure that nothing will impede driving (anything obstructing the pedals, heel wedged by the mat etc.).

Do not do the following



Position objects such as deodorants, perfumes etc. near air vents as this could damage your dashboard trim.

Use high-pressure or spray cleaning equipment inside the passenger compartment: if not used with care, this equipment could impair the correct functioning of the electrical or electronic components in the vehicle, or have other detrimental effects.

TYRES

Tyres

The tyres are the only contact between the vehicle and the road, so it is essential to keep them in good condition. You must make sure that your tyres conform to local road traffic regulations.

Maintaining the tyres



The tyres must be in good condition and the treads must have sufficient depth: tyres approved by our Technical Department have wear warning strips **1** which are **indicators moulded into the tread at several points**.

When the tyre tread has been worn to the level of the wear indicators, **they become visible 2: it is then necessary to replace your tyres because the tread rubber is 1.6 mm deep at most, resulting in poor road-holding on wet roads.**

An overloaded vehicle, long journeys by motorway, particularly in very hot weather, or continual driving on poorly surfaced minor roads will lead to more rapid tyre wear and affect safety.



Incidents which occur when driving, such as striking the kerb, may damage the tyres and wheel rims, and could also lead to misalignment of the front or rear axle geometry. In this case, have the condition of these checked by an approved dealer.

Tyre pressures

Adhere to the tyre pressures (including the emergency spare wheel). The tyre pressures should be checked at least once a month and additionally before any long journey (refer to the label affixed to the edge of the driver's door).



Incorrect tyre pressures lead to abnormal tyre wear and unusually hot running. These are factors which may seriously affect safety and lead to:

- poor road holding,
- the risk of blow-outs or of throwing a tread.

The pressure depends on the load and the speed of use. Adjust the pressure according to the conditions of use (refer to the label affixed to the edge of the driver's door).

Pressures should be checked when the tyres are cold. Ignore higher pressures which may be reached in hot weather or after driving at high speed.

If tyre pressures cannot be checked when the tyres are **cold, assume an increase of 0.2 to 0.3 bar** (or 3 PSI).

Never deflate a hot tyre.

TYRES



Please be aware that a poorly tightened or missing valve cap can make the tyres less airtight and may lead to pressure loss. Always use valve caps identical to the originals and screw them down fully.

Vehicle fitted with a tyre pressure loss warning system

In the event of under-inflation (punctures, flat tyre, etc.), the  warning light appears on the instrument panel → 204.

Changing wheels around

This practice is not recommended.

Emergency spare wheel

→ 337

Fitting new tyres



For your safety and to comply with the law. When they need to be replaced, only tyres of the same make, size, type and profile should be used on a single axle.

They must either have a load capacity and speed rating at least equal to those of the original tyres, or conform to those recommended by an authorised dealer.

Failure to heed these instructions could endanger your safety and affect your vehicle's roadworthiness.

Risk of loss of control of the vehicle.



Chains may only be fitted to tyres of the same size as those originally fitted to **your vehicle**. Only certain chains can be fitted to tyres. Consult an approved dealer.

Use in winter

Chains

For safety reasons, fitting snow chains to the rear axle is strictly forbidden.

Chains cannot be fitted to tyres which are larger than those originally fitted to the vehicle.

"Snow" or "Winter" tyres

We recommend that these be fitted to all **four wheels** to ensure that your vehicle retains maximum traction.

Caution: these tyres sometimes have a specific direction of rotation and a maximum speed index which may be lower than the maximum speed for your vehicle.

TYRES

Studded tyres

This type of equipment may only be used for a limited period and as laid down by local legislation.

It is necessary to observe the speed specified by current legislation.

These tyres must, at a minimum, be fitted to the two front wheels.



In all cases, we would recommend that you contact an approved Dealer who will be able to advise you on the choice of equipment which is most suitable for your vehicle.



17" wheels cannot be fitted with chains.

If you wish to fit snow chains, you must use

special equipment.

Consult an approved dealer.

Tyre pressure



For your safety and to comply with the law. When they need to be replaced, only tyres of the same make, size, type and profile should be used on a single axle.

They must either have a load capacity and speed rating at least equal to those of the original tyres, or conform to those recommended by an authorised dealer.

Failure to heed these instructions could endanger your safety and affect your vehicle's roadworthiness.

Risk of loss of control of the vehicle.

Label A

36615

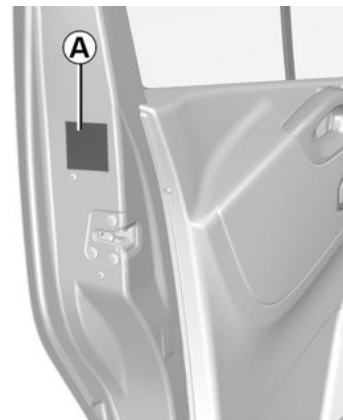

Open the door to read it.

Tyre pressures should be checked when the tyres are cold.

If tyre pressures cannot be checked when the tyres are **cold, assume an increase of 0.2 to 0.3 bar (or 3 PSI)**. **Never deflate a hot tyre.**

Vehicle fitted with a tyre pressure loss warning system

In the event of under-inflation (punctures, under-inflation etc.), warning

light appears on the instrument panel ➔ 204.

TYRES

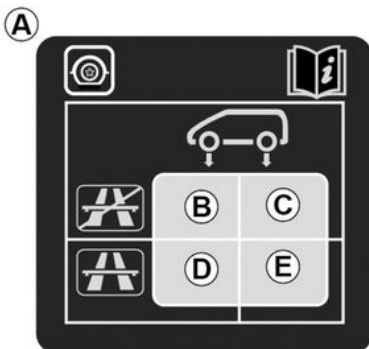

B. Front tyre pressure when driving (non-motorway), or if less than four people are occupying the vehicle.

C. Rear tyre pressure when driving (non-motorway), or if less than four people are occupying the vehicle.

D. Front tyre pressure when driving (motorway) or when driving with a significant load.

E. Rear tyre pressure when driving (motorway) or when driving with a significant load.



Vehicle used fully laden (Maximum Permissible Load Weight MAXI) and towing a

trailer

The maximum speed must be limited to 62 mph (100 km/h) and the tyre pressure increased by 0.2 bar → 382 .

Risk of tyre blowouts.

Tyre safety and chain fitting: for information on maintenance conditions and, depending on the vehicle version, the use of chains → 336.

Tyre inflation kit

32788



The kit repairs tyres when the tread **A** has been damaged by objects smaller than 4 mm.

It cannot repair all types of puncture, such as cuts larger than 4 mm, cuts in the tyre sidewall **B**, etc.

Ensure also that the wheel rim is in good condition.

Do not pull out the foreign body causing the puncture if it is still in the tyre.

TYRES



Do not attempt to use the inflation kit if the tyre has been damaged as a result of driving with a

puncture.

You should therefore carefully check the condition of the tyre sidewalls before any operation. Driving with underinflated, flat or punctured tyres can be dangerous and may make the tyre impossible to repair.

This repair is temporary.

A tyre which has been punctured should always be inspected (and repaired, where possible) by a specialist as soon as possible. When taking a tyre which has been repaired using this kit to be replaced, you must inform the specialist.

When driving, vibration may be felt due to the presence of the repair product injected into the tyre.



The kit is only approved for inflating the tyres of the vehicle originally equipped with the kit.

It must never be used to inflate the tyres of another vehicle, or any other inflatable object (rubber ring, rubber boat, etc.).

Avoid spillage on skin when handling the repair product bottle. If droplets do leak out, rinse them off with plenty of water.

Keep the repair kit away from children.

Do not dispose of the empty bottle in the countryside. Return it to your approved dealer or to a recycling organisation.

The bottle has a limited service life which is indicated on its label.

Check the expiry date.

Contact an approved dealer to replace the inflation tube and repair product bottle.

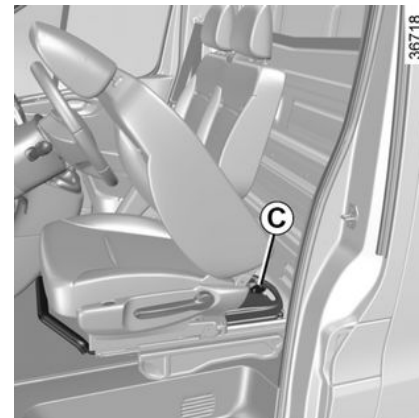

Depending on the vehicle, in the event of a puncture, use the kit located in the tool kit underneath the driver's seat.

To remove it, move the seat as far forwards as possible and tilt the seat-back. Loosen the mounting bolt **C** from the unit and swivel it to extract it.

Vehicle fitted with a tyre pressure loss warning system

In the event of under-inflation (punctures, under-inflation etc.), the  warning light appears on the instrument panel ➔ 204.

TYRES



Before using the kit, park the vehicle at a sufficient distance from traffic, switch on the hazard warning lights, apply the parking brake, ask all passengers to leave the vehicle and keep them away from traffic.



If the vehicle is parked on the hard shoulder, you must warn other road users of your vehicle's presence with a warning triangle or with other devices as per the legislation applying to the country you are in.

35749

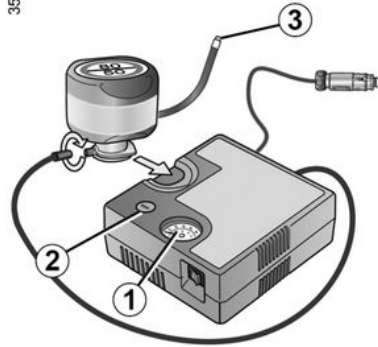

With the engine running and the parking brake applied

- Disconnect any accessories from the vehicle's accessories sockets;
- **refer to the information on the inflation kit compressor** that is located under the driver's seat and follow the instructions for use;
- inflate the tyre to the recommended pressure ➔ **338**;
- after a maximum of **15** minutes, stop inflating and read the pressure (on the pressure gauge **1**);

Note: while the container is emptying (approximately 30 seconds), the pressure gauge **1** will briefly indicate a pressure of up to **6 bar**, then the pressure drops.

- adjust the pressure: to increase it, continue inflation with the kit. To reduce it, press the button **2**.

If the recommended pressure of 1.8 bar cannot be achieved after 15 minutes, repair is impossible. Do not drive the vehicle. Consult an approved dealer.



Nothing should be placed around the driver's feet as during sudden braking such objects may slide under the pedals and obstruct their use.

Once the tyre is correctly inflated, remove the kit:

- slowly unscrew the container inflation adapter **3** to avoid any product spatter and store the container in plastic packaging to prevent product leaks.
- affix the driving recommendation label to the dashboard where it can easily be seen by the driver;
- put the kit away;
- at the end of this initial inflation operation, air will still escape from the tyre; you must drive a short distance in order to seal the hole;
- start the vehicle immediately and drive at a speed of 12 to 37 mph (20 to 60 km/h).

TYRES

60 km/h) in order to distribute the product evenly in the tyre. After driving a distance of 2 miles (3 km), stop the vehicle and check the tyre pressure; – if the pressure is higher than 1.3 bar but lower than the recommended pressure (see the label affixed to the edge of the driver's door), adjust it. Otherwise, contact an approved dealer: the tyre cannot be repaired.

Precautions when using the kit

The kit should not be operated for more than 15 consecutive minutes.

The container must be replaced after the first use even if liquid remains inside.



Following repair with the kit, do not travel further than 124 miles (200 km).

In addition, reduce your speed and under no circumstances exceed 50 mph (80 km/h). The sticker, which you must affix in a prominent position on the dashboard, reminds you of this. Depending on the country or local legislation, a tyre repaired with the inflation kit will need to be replaced.



Please be aware that a poorly tightened or missing valve cap can make the tyres less airtight and may lead to pressure loss. Always use valve caps identical to the originals and screw them down fully.



Nothing should be placed on the floor (area in front of the driver) as these objects may slide under the pedals during sudden braking manoeuvres, thus obstructing their use.

Tools



Do not leave the tools unsecured inside the vehicle **as they may be projected during braking**. After use, check that all the tools are correctly clipped into the tool kit, then position it correctly in its housing to reduce the **risk of injury**.

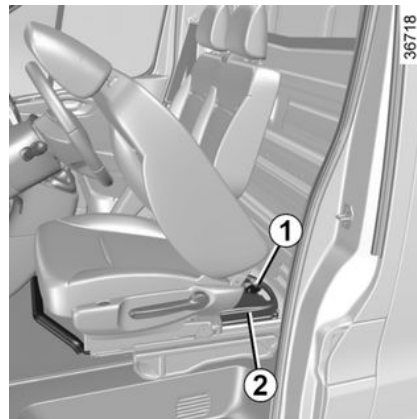

The tools included in the tool kit depend on the vehicle. The tool kit **2** is located under the driver's seat. To take it out, move the seat forward and fold down the seatback → **54**. Loosen the mounting bolt **1** from the unit and swivel it to extract it.

Jack 3

TYRES

Fold it correctly before refitting it in its housing (ensure that the wheelbrace is correctly positioned).

Wheel bolt anti-theft piece 4

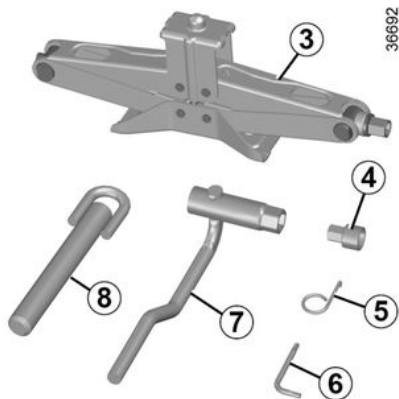

Hubcap tool 5

This tool is used to remove the wheel trims.

Offset wrench 6

Wheelbrace 7

This locks and unlocks the wheel bolts and the emergency spare wheel holder.

Towing eye 8 → 349



For your safety, the use of a jack not recommended by the manufacturer is strictly prohibited.

The jack is specific to the vehicle and used to change the wheels. Under no circumstances should it be used:

- on another vehicle;
- to carry out a repair;
- to access the underside of the vehicle.

Risk of injury.

Risk of damage to the vehicle.

TYRES

Puncture, emergency spare wheel



If the spare wheel has been stored for several years, have it checked by your Dealer to ensure that it is safe to use.

Vehicle equipped with an emergency spare wheel that differs from the other four wheels:

- Never fit more than one emergency spare wheel to the same vehicle.
- The punctured wheel is wider than the emergency spare wheel, so the height of the vehicle ground clearance is reduced.
- Replace the emergency spare wheel as soon as possible with a wheel identical to the original one.
- When this is fitted to the vehicle, which must only be a temporary measure, the driving speed must not exceed the speed indicated on the label on the wheel.
- Fitting an emergency spare wheel may alter the way the vehicle usually runs. Avoid sudden acceleration or deceleration and reduce your speed when cornering.
- If you need to use snow chains, fit the emergency spare wheel to the rear axle and check the tyre pressure.

TYRES

In case of puncture



If the vehicle is parked on the hard shoulder, you must warn other road users of your vehicle's presence with a warning triangle or with other devices as per the legislation applying to the country you are in.



In some cases (rear puncture, vehicle loaded with towing equipment etc.), it is necessary to raise the vehicle (using the lifting point nearest the wheel concerned) to permit access to the emergency spare wheel.

Depending on the vehicle, the following may be available:

- a tyre inflation kit → 339;
- an emergency spare wheel → 345.

Vehicle fitted with a tyre pressure loss warning system

In the event of under-inflation (punctures, under-inflation etc.), the warning light appears on the instrument panel → 204.



Emergency spare wheel

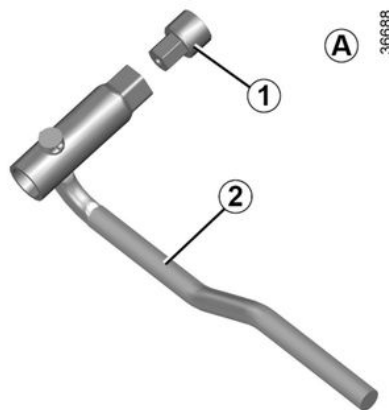

On equipped vehicles, **you must use tool A** which consists of:

- the wheelbrace **2**;
- for some versions, a special end piece **1** (which must be added).

These components are stored in the tool kit → 0.

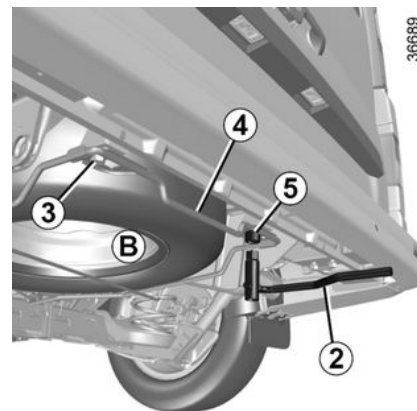

To take out the emergency spare wheel **B**

Use the tool **A** to completely loosen the nut **5** (right-hand side) and partially loosen the nut **3** (left-hand side) until the notch of the wheel carrier **4** is released from the nut **3**.

Move it up and down and from side to side to release the emergency spare wheel.

Depending on the vehicle, a note in the tool kit covers these instructions.

TYRES

To refit the emergency spare wheel B



Do not touch the exhaust system.
Risk of burns.

Proceed in reverse order. Check that the wheel carrier **4** is correctly positioned before tightening nuts **3** and **5**.

Note: do not fit the wheel trim on the emergency spare wheel in order not to hide the safety message displayed on the label affixed to the emergency spare wheel. The message indicates the 50 mph (80 km/h) speed limit. Please abide by the limits set by the local legislation of the country that you are in.

Changing a wheel



Switch on the hazard warning lights. Keep the vehicle away from traffic and on a level surface where it will not slip. Apply the parking brake and engage a gear (first or reverse, or P position on an automatic gearbox). Ask the passengers to leave the vehicle and to keep away from traffic.



If the vehicle is parked on the hard shoulder, you must warn other road users of your vehicle's presence with a warning triangle or with other devices as per the legislation applying to the country you are in.



Do not leave the tools unsecured inside the vehicle **as they may be projected during braking**. After use, check that all the tools are correctly clipped into the tool kit, then position it correctly in its housing to reduce the **risk of injury**.



If you have a puncture, replace the wheel as soon as possible. A tyre which has been punctured should always be inspected (and repaired, where possible) by a specialist.

TYRES



Remove the wheel trim → 0.

Unlock the wheel bolts using the wheel brace **1**. Position it so as to be able to push from above.



Anti-theft bolt

If you use anti-theft bolts, fit these nearest the valve (otherwise it may not be possible to fit the wheel trim).

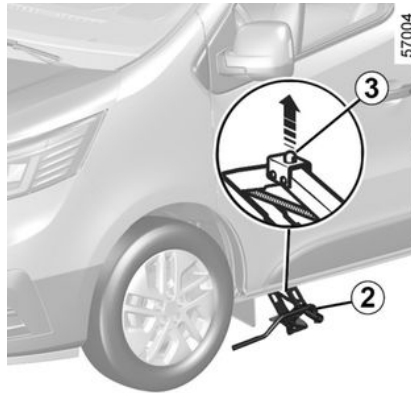

Position the jack **2** horizontally, with the head pin **3** aligned with the hole **4** in the lower part of the bodywork nearest the wheel concerned.

Begin to crank the jack so that the baseplate is correctly positioned (it should be underneath the vehicle and aligned with the jack head).

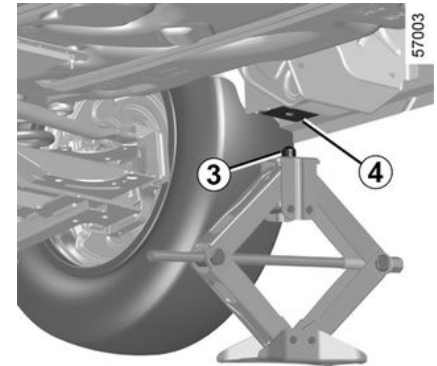

Loosen the wheel nuts and remove the wheel.

Fit the emergency spare wheel in place on the centre hub.

Tighten the nuts and lower the jack.

With the wheels on the ground, tighten the nuts fully and check if they are tight as quickly as possible.

Position the trim.

TYRES



For your safety, the use of a jack not recommended by the manufacturer is strictly prohibited.

The jack is specific to the vehicle and used to change the wheels. Under no circumstances should it be used:

- on another vehicle;
- to carry out a repair;
- to access the underside of the vehicle.

Risk of injury.

Risk of damage to the vehicle.

Wheel trim, wheel



Do not leave the tools unsecured inside the vehicle **as they may be projected during braking**. After use, check that all the tools are correctly clipped into their casings, then position them correctly in their housings to reduce the **risk of injury**.

Trim 1

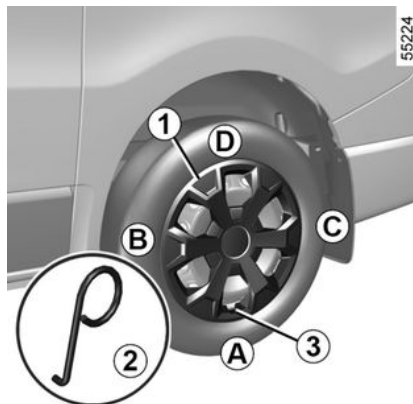

Remove it by using the hubcap tool **2** (located in the tool kit) to fit the hook into one of the openings around the edge of the wheel trim.

To refit it, align it with the valve **3**.

Push the retaining hooks in fully, starting on the side of valve **A**, followed by **B** and **C**, finishing at the side opposite valve **D**.

Trim 4

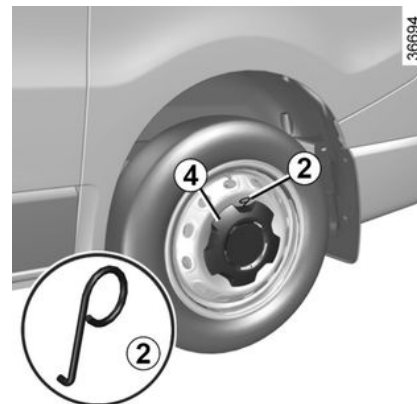

Remove it using the hubcap tool **2** (located in the tool kit) by engaging the hook in the opening near the edge of the trim.

To refit, position the five trim attachments facing the five wheel attachments and press hard in the middle of the trim to clip it to the wheel.

BREAKDOWN RECOVERY

Towing: breakdown



- Use a rigid tow bar. If a rope or cable is used (where the law allows this), the vehicle being towed must be able to brake.
- a vehicle must not be towed if it is not fit to be driven.
- Do not accelerate or brake suddenly when towing, as this may result in damage to the vehicle.
- In any case, you are advised not to exceed 16 mph (**25 km/h**).
- Do not push the vehicle if the steering column is locked.



When the engine is stopped, steering and braking assistance are no longer provided.



Do not remove the key from the ignition switch or the card from the reader during towing.

Before towing, put the gearbox in neutral, unlock the steering column and release the parking brake.

On vehicles fitted with an automatic gearbox, if it is not possible to set the gear lever to N position, consult an authorised dealer.

Steering column unlocking

Insert the key into the ignition or, depending on the vehicle, with the card on you, press the engine start button for approximately **two seconds**.

Reposition the lever to neutral (N position on vehicles fitted with an automatic gearbox).

The steering column unlocks and the accessory functions are powered: you can use the vehicle's lights (direction indicators, brake lights, etc.). At night the vehicle must have its lights on.

Depending on the vehicle, once you have finished towing, press the engine start button twice (risk of running down the battery).

Remove any trailer.

Never use the drive shafts or axles.

The towing points may only be used for towing the vehicle and never for lifting it, either directly or indirectly.

The speed specified by current legislation for towing must always be observed. If you are driving the towing vehicle, do not exceed the permissible towing weight for your vehicle. ➔ **382**.

Towing a vehicle fitted with an automatic gearbox

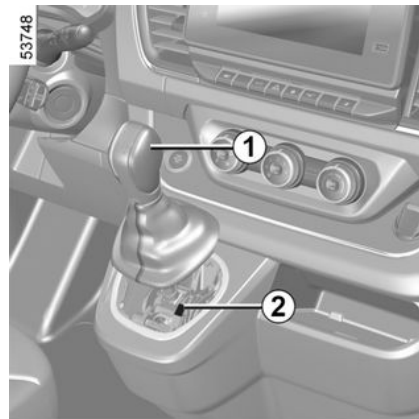

Transport the vehicle on a trailer or tow it with the front wheels off the ground.

In exceptional circumstances, you may tow it with all four wheels on the ground, forwards only, with the gear lever in neutral position N over a maxi-

BREAKDOWN RECOVERY

maximum distance of 50 miles (80 km) and not exceeding a speed of 16 mph (25 km/h).

When setting off, if the lever is locked in position P even though you are pressing the brake pedal, the lever can be released manually. To do this, unclip the base of the lever then place a tool (rigid shaft) into the slot **2** (located to the left or right of the lever). Press simultaneously on the tool (rigid shaft) and the button **1** to unlock the lever.

Contact your approved Dealer as soon as possible;

6

Use only

Rear:

- on vehicles without towing equipment, towing point **3**;
- on vehicles with towing equipment, towing point **4** (tow ball).

Front:

- at the front, the towing eye **6** (located in the tool kit) and the towing point.

Rear towing point **3**

(Vehicle without towing equipment)

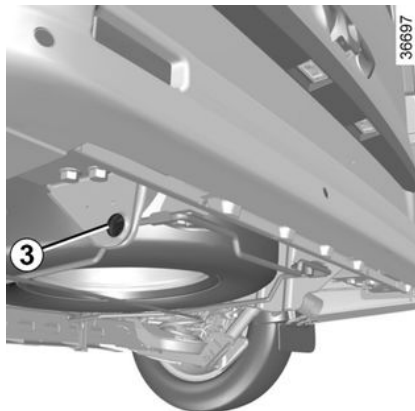

Rear towing point **4**

(Vehicle with towing equipment)



To assemble the towbar ball, please consult the equipment assembly instructions.



Ensure that the towing ring is bolted correctly.
Risk of losing the towed object.

Front towing point

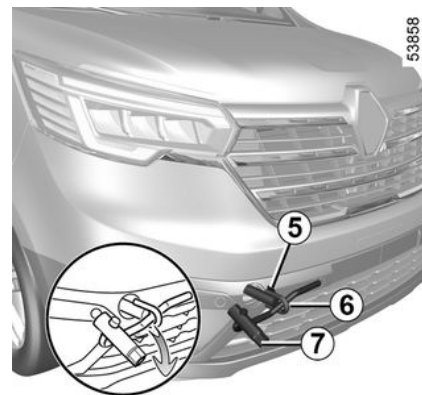

Unclip the cover **5** by inserting a flat-blade screwdriver or similar under the cover.

Screw in the towing eye **6 completely:** first by hand as far as possible, then lock using the wheelbrace **7**.

BREAKDOWN RECOVERY

Only use the towing ring **6** stored with the tools → **0**.

Battery: troubleshooting



Handle the battery with care as it contains sulphuric acid which must not come into contact with the eyes or skin. If it does, wash the affected area with plenty of cold water. If necessary, consult a doctor.

Keep any flames, red hot objects or sparks away from the battery components (**risk of explosion**). Please note when working close to the engine that it may be hot. The engine cooling fan may also



start at any moment. The label in the engine compartment reminds you of this.

Risk of injury.



Before carrying out any action in the engine compartment, you must switch off the ignition

→ **180**.



Special procedures may be required to charge some batteries. Contact your approved dealer.

Avoid all risk of sparks which may cause an immediate explosion, and charge the battery in a well ventilated area.

Risk of serious injury.

To avoid all risk of sparks:

- Ensure that the "energy consumers" (ceiling lights, etc.) are switched off before disconnecting or reconnecting a battery;
- when charging, switch off the charger before connecting or disconnecting the battery;
- do not place any metal objects on the battery as this may create a short circuit across the terminals;

- always wait at least one minute after the engine has been switched off before disconnecting a battery;
- make sure that you reconnect the battery terminals after refitting.

Connecting a battery charger

The battery charger must be compatible with a battery with nominal voltage of 12 volts.

Do not disconnect the battery while the engine is running. **Follow the instructions given by the manufacturer of the battery charger you are using.**

Starting the vehicle using the battery from another vehicle



Ensure that there is no contact between cables **A** and **B** and that positive cable **A** is not in contact with any metallic component in the vehicle supplying the current.

Risk of injury and/or damage to the vehicle.

If you have to use the battery from another vehicle to start, obtain suitable jump leads (with a large cross section)

BREAKDOWN RECOVERY

from an approved dealer or, if you already have jump leads, ensure that they are in perfect condition.

The two batteries must have an identical nominal voltage: 12 V. The battery supplying the current should have a capacity (amp-hours, Ah) which is at least the same as that of the discharged battery.

Ensure that there is no risk of contact between the two vehicles (risk of short circuiting when the positive terminals are connected) and that the discharged battery is properly connected. Switch off your vehicle ignition.

Depending on the vehicle, unclip the battery cover.

Connect the positive cable **A** to the terminal **1** (+) then to the **terminal 4** (+) of the battery supplying the current.

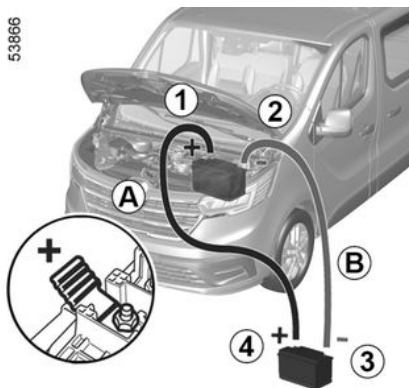

Connect the negative cable **B** to the **terminal 3 (-) of the battery supplying the current and then to the terminal 2 (-) of the discharged battery.**

Start the engine of the vehicle supplying the current and run it at an intermediate engine speed.

With the engine running, the "12 V battery charging" message appears on the instrument panel for approximately five minutes.

If your vehicle's engine does not start immediately, switch off the ignition and wait a few seconds before repeating the operation.

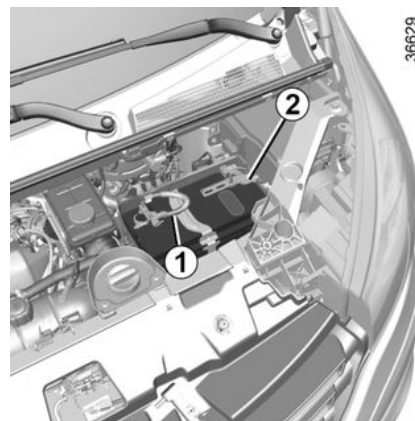

With the engine running, disconnect cables **A** and **B** in the reverse order (**2 - 3 - 4 - 1**).

HEADLIGHTS, LIGHTS: REPLACING BULBS

Exterior lighting: replacing bulbs

Front and side headlights



Please note when working close to the engine that it may be hot. The engine cooling fan may also start at any moment. The



label in the engine compartment reminds you of this. **Risk of injury.**



Any operation on (or modification to) the electrical system must be performed by an approved Dealer since an incorrect connection might damage the electrical equipment (harness, components and in particular the alternator). In addition, your Dealer has all the parts required for fitting these units.



Before carrying out any action in the engine compartment, you must switch off the ignition

→ 180.

LED daytime running lights and direction indicator lights 1

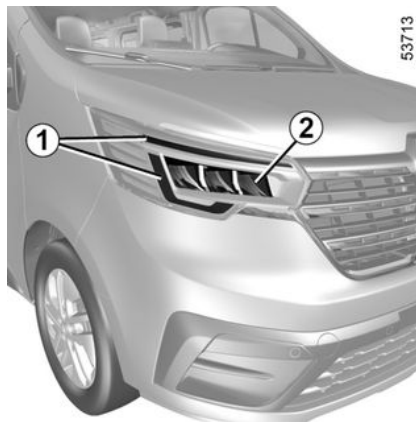

Consult an approved dealer.

LED main beam headlights 2

Consult an approved dealer.



To comply with local legislation, or as a precaution, you can obtain an emergency kit containing a set of spare bulbs and fuses from an approved dealer.



The bulbs are under pressure and may break when replaced. **Risk of injury.**

LED dipped beam headlights 3

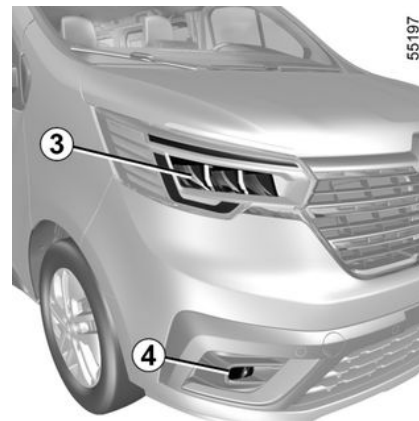

HEADLIGHTS, LIGHTS: REPLACING BULBS

Consult an approved dealer.

LED fog lights 4

Consult an approved dealer.

LED side repeaters 5

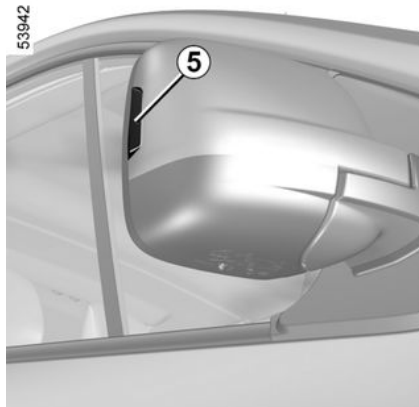

Consult an approved dealer.

Additional lights

If you wish to fit fog lights or long-range headlights to your vehicle, consult an approved dealer.



The bulbs are under pressure and may break when replaced.

Risk of injury.

Rear lights

Rear lights unit A

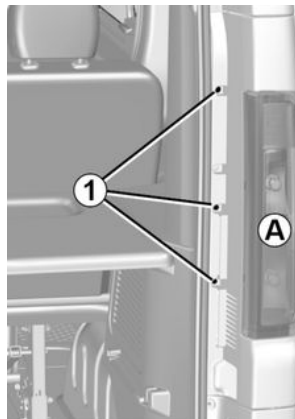

Remove the bolts 1.



The bulbs are under pressure and may break when replaced.

Risk of injury.

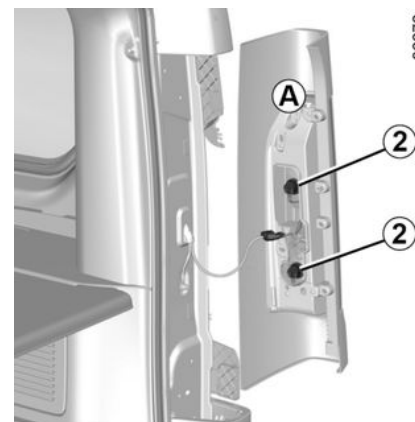

Turn the lights unit slightly and release it to access the bulb holder 2.

Unclip the bulb holders by rotating them a quarter of a turn.

Unclip the bulbs by pressing them slightly and rotating them a quarter of a turn.

HEADLIGHTS, LIGHTS: REPLACING BULBS

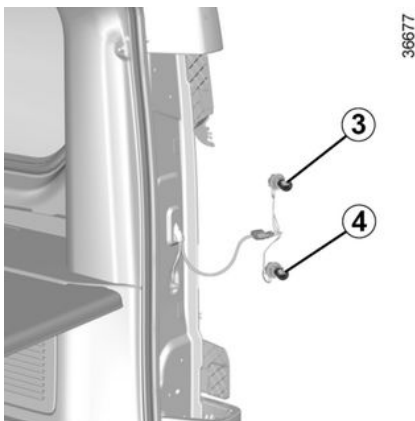

Direction indicator lights **3**

Pear-shaped, bayonet type bulb PY 21W.

Side and brake lights **4**

Pear-shaped, bayonet type bulb P 21/5W.

Rear lights unit **B**

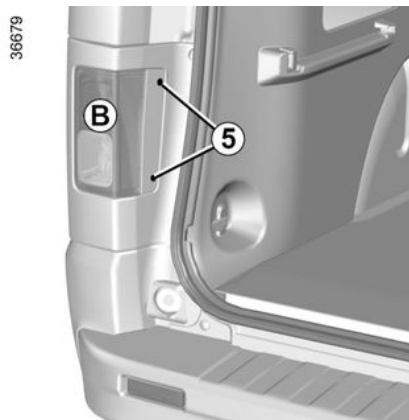

Remove the bolts **5**.

Release the headlight unit.

Turn the bulb holder **6** or **7** and release it.

Replace the bulb concerned.

Refit the bulb holder and secure it by turning.

Check that it is securely mounted.

Reposition the headlight unit and screw it in place.

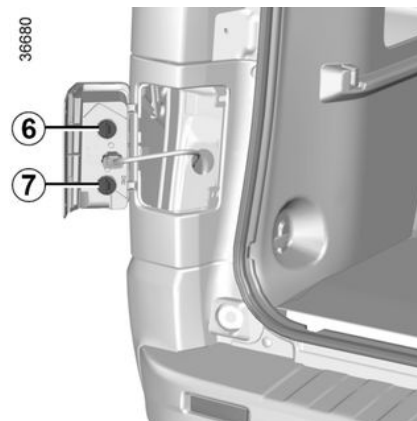

6. (driver's side only)

Fog light

Pear-shaped, bayonet type bulb W16W.

7. Reversing light

Pear-shaped, bayonet type bulb W16W.

HEADLIGHTS, LIGHTS: REPLACING BULBS

High-level brake light on rear hinged doors

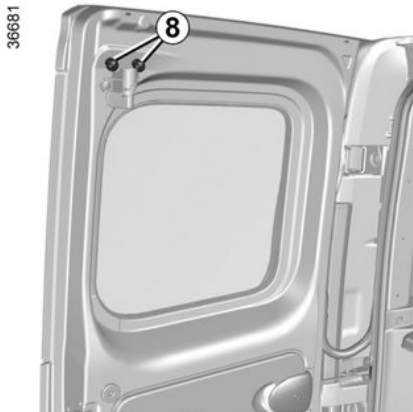

Remove the nuts **8**.

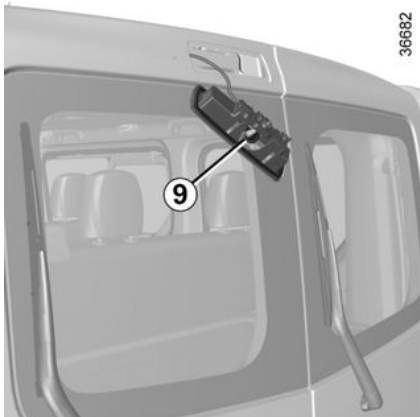

Remove the light sideways from the outside to access the bulb **9**.

Pear-shaped, bayonet type bulb P 21W.

High-mounted brake light on tail-gate

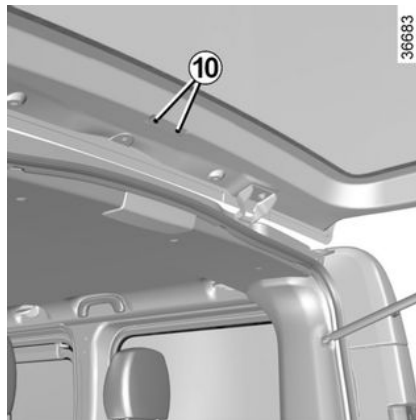

Remove the nuts **10**.

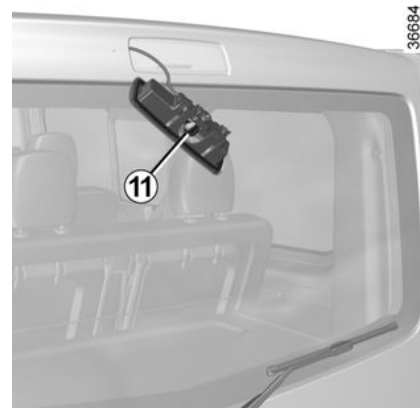

Remove the light from the outside to access the bulb **11**.

Pear-shaped, bayonet type bulb P 21W.

HEADLIGHTS, LIGHTS: REPLACING BULBS

Number plate lights

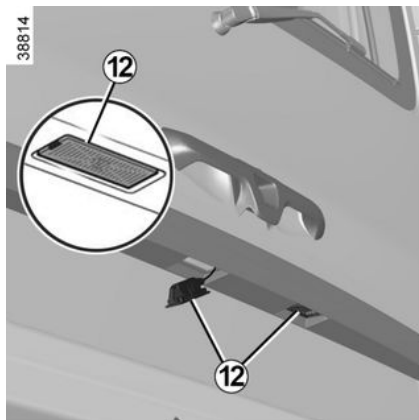

The bulb is accessed in the same way for both vehicles with hinged doors and those with the tailgate.

Unclip the light **12** (using a tool such as a flat-blade screwdriver).

Remove the light cover to gain access to the bulb.

Bulb type: W5W.

Interior lighting

LED interior lights **1** and **2**



(depending on the vehicle)
Consult an approved dealer.



The bulbs are under pressure and may break when replaced.
Risk of injury.

HEADLIGHTS, LIGHTS: REPLACING BULBS

Glovebox light 3

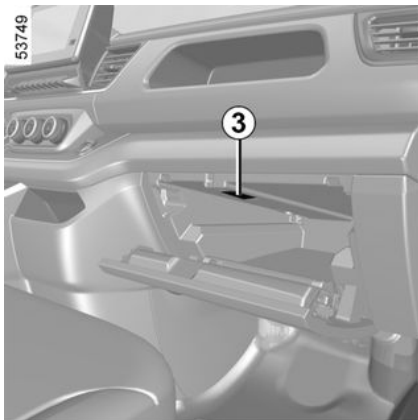

Remove the lens using a tool such as a flat-blade screwdriver.

Pull the bulb to remove it from its housing.

Bulb type: W5W

Replace the bulb and refit the lens.

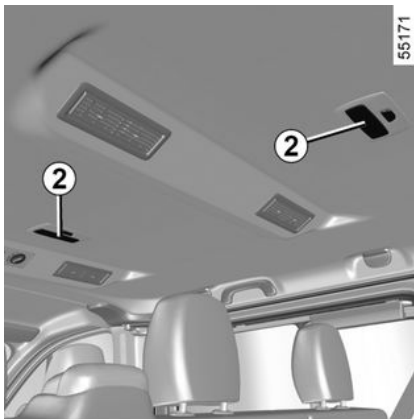

Bulb type 2: W5W

(depending on the vehicle)

Replace the bulb and refit the lens.

Lights 4

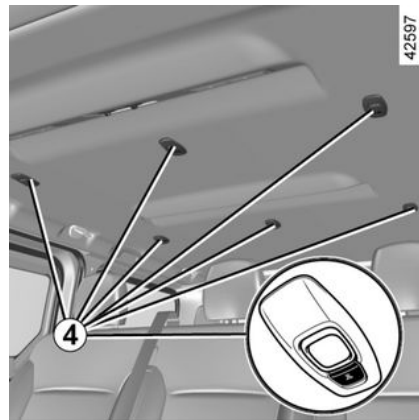

Consult an approved dealer.

HEADLIGHTS, LIGHTS: REPLACING BULBS

Light 5



Remove the lens using a tool such as a flat-blade screwdriver.

Pull the bulb to remove it from its housing.

Bulb type: W5W

Replace the bulb and refit the lens.

Light 6

(depending on the vehicle)

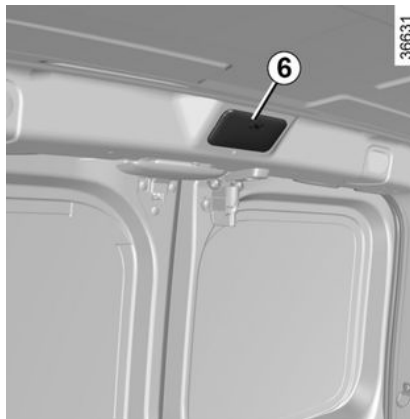

Bulb version

Remove the lens using a tool such as a flat-blade screwdriver.

Pull the bulb to remove it from its housing.

Bulb type: W5W

Replace the bulb and refit the lens.

LED version

Consult an approved dealer.

WIPER BLADES: REPLACEMENT



– In frosty weather, make sure that the wiper blades are not stuck by ice (risk of motor overheating).
– Check the condition of the wiper blades.

Replace the wiper blades as soon as they begin to lose efficiency (approximately once a year). Whilst changing the blade, take care not to drop the arm onto the window after it has been removed as this may break the window.

6

Windscreen wiper blades 1

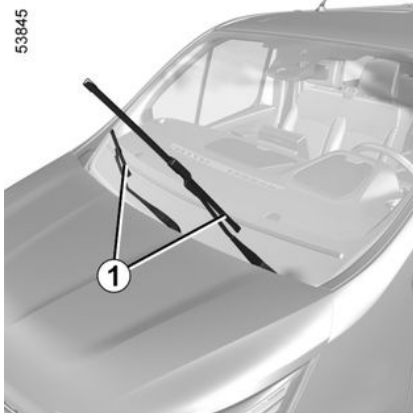

With the ignition on and the ignition switched off, lower the windscreen wiper stalk fully: the wipers stop in a position away from the bonnet.

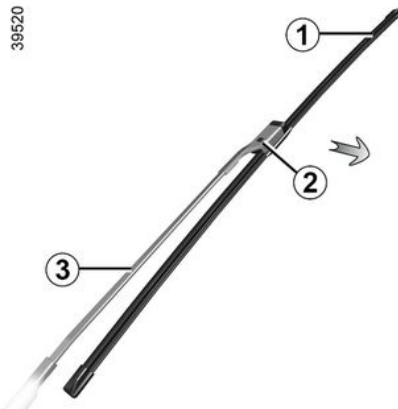

Lift the windscreen wiper arm **3**, press the button **2** to release the blade **1**.

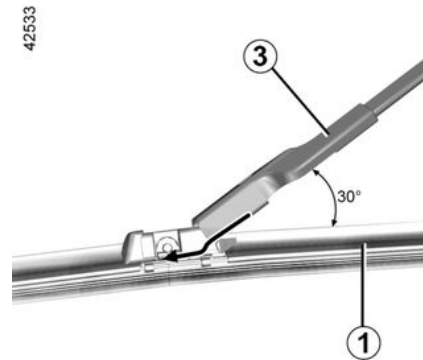

Refitting

WIPER BLADES: REPLACEMENT

Position the blade **3** of the wiper arm **1** at an angle of 30°.

Slide the blade along the arm until it clips on. Check that it is correctly locked. Lower the windscreen wiper arm carefully.

With the ignition on, return the windscreen wiper stalk to the stop position.



Check the condition of the wiper blades. You are responsible for their service

life:

- clean the blades, windscreen and rear screen regularly with soapy water;
- do not use them when the windscreen or rear screen is dry;
- free them from the windscreen or rear screen when they have not been used for a long time.

Rear screen wiper blade on rear hinged doors

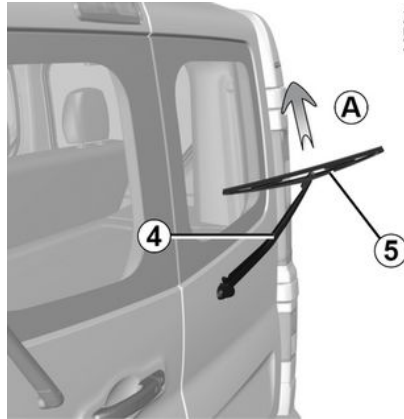

- Lift the wiper arm **4**;
- pivot the blade **5** until you meet some resistance;
- pull the blade to release it (movement **A**).

Rear screen wiper blade on tailgate



- Lift the wiper arm **6**;
- pull the tab **8** (movement **B**) and push the blade **7** upwards.

WIPER BLADES: REPLACEMENT

Refitting

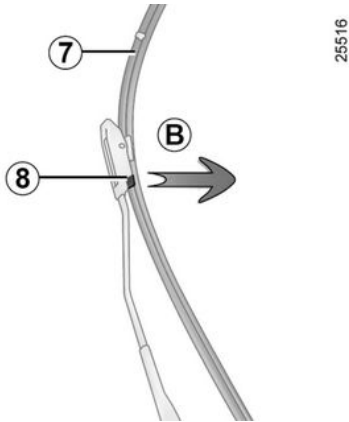

Proceed in the reverse order to removal. Make sure that the blade is correctly locked in position.

6

FUSES

Passenger compartment fuses



Check the fuse in question and, **if necessary, replace it (replacement fuse must have the same rating as the original).**

If a fuse is fitted with too high a rating, it may cause the electrical circuit to overheat (risk of fire) in the event of an item of equipment using an excessive amount of current.

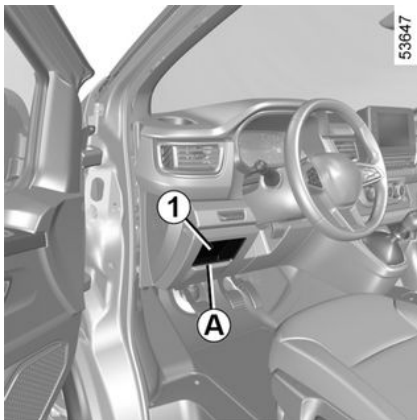

If any electrical equipment does not work, check the condition of the fuses.

To access the fuses, pull the edge **A** of the storage compartment **1** firmly towards you.

To reposition the storage compartment **1**, engage the centring pins **2** in the openings **3**. Then, slightly lower the storage compartment **1** to align the clips **4** with their respective notches.

Apply pressure at the top, at the middle and at the bottom of the storage compartment to lock it correctly.

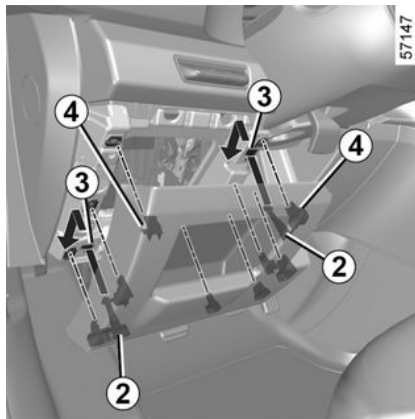

Tweezers 5

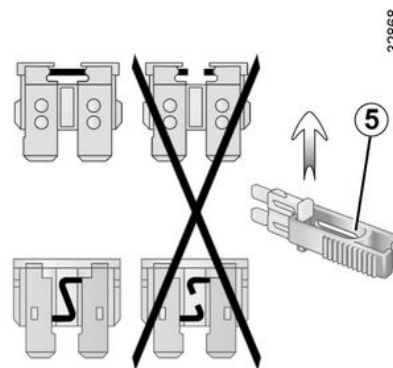

Remove the fuse using the tweezers **5**, located on the back of the flap **1**.

To remove the fuse from the tweezers, slide the fuse to the side.

It is not advisable to use the free fuse locations.











To comply with current legislation, or as a precaution, you can obtain an emergency kit from your approved dealer containing a set of spare bulbs and fuses.

FUSES

Allocation of fuses

(the presence and location of fuses depends on the vehicle equipment level)

Icon	Icon
	Windscreen washer
	Multimedia accessories socket, multimedia screen
	Front and rear second row accessories socket
	Horn
	Towbar socket
	Heated rear view mirrors
	Brake lights, passenger compartment central unit
	Passenger compartment centre unit, rear wiper, rear fog light
	Direction indicator lights, hazard warning lights, high level brake lights



Use the fuse allocation label in the storage compartment to identify the fuses.

Certain fuses should only be replaced by a qualified professional. These fuses are not listed on the label.

Only change the fuses represented on the label.

FITTING A RADIO

Location of the radio 1

(depending on the vehicle)



The presence of connections and the location of this equipment depend on the vehicle version.

To install any radio equipment, please consult an approved dealer.

Location of the speakers 2

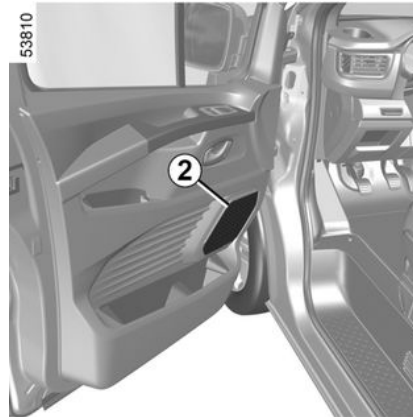

To install speakers, please consult an approved dealer.

i To use this equipment, consult the equipment instructions which should be kept with the other vehicle documentation.

i – In all cases, follow the manufacturer's instructions carefully.

– The specifications of the brackets and wires (available from our Network) vary depending on the equipment level of your vehicle and the type of radio.

Consult an approved Dealer to find out the correct part number.

– No work may be carried out on the vehicle's electrical or radio circuits, except by approved Dealers: an incorrectly connected system may result in damage being caused to the electrical equipment and/or the components connected to it.

INSTALLATION AND USE OF ACCESSORIES

Installation and use of accessories: important recommendations



Electrical and electronic accessories

Before installing this type of accessory (particularly for transmitters/receivers: frequency bandwidth, power level, position of the aerial, etc.), make sure it is compatible with your vehicle. Contact an approved dealer.

Before connecting an accessory to a socket, ensure that it does not exceed the maximum power authorised for the socket → 0, → 303. **Fire hazard.**

No work may be carried out on the vehicle's electrical and/or electronic circuits, except by a qualified professional. In fact, an incorrect connection and/or the installation of electrical/electronic accessories not approved by the manufacturer could lead to:

- damage to the electrical and/or electronic equipment;
- damage to the components connected to it;
- the collection and use of vehicle data;
- an invasion of privacy (modification, deletion or unwarranted access to personal data);
- cancellation of the authorisation for entry into service.

Risk of serious accidents.

Risk of invasion of privacy.

If you have electrical equipment fitted in future, make sure that you are notified of the rating and position of the corresponding fuse.

Using the diagnostic socket

The use of electronic accessories on the diagnostic socket may cause serious disturbance to the vehicle's electronic systems and/or cause invasion of privacy (modification, deletion or unwarranted access to personal data).

For your safety, we recommend that you only use electronic accessories approved by the manufacturer: consult an approved dealer.

Risk of serious accidents.

Risk of invasion of privacy.

INSTALLATION AND USE OF ACCESSORIES



Fitting aftermarket accessories

If you wish to install accessories on the vehicle: consult an approved dealer. Also, to ensure the correct operation of your vehicle, and to avoid any risk to your safety, we recommend that you use only accessories specifically designed for your vehicle, which are the only accessories for which the manufacturer will provide a warranty.

If you are using an anti-theft device, only attach it to the brake pedal.

Driver obstruction

On the driver's side, only use mats suitable for the vehicle, attached with the pre-fitted components, and check the fitting regularly. Do not lay one mat on top of another.

There is a risk of wedging the pedals.

OPERATING FAULTS

The following advice will enable you to carry out quick, temporary repairs. For safety reasons you should always contact an approved dealer as soon as possible.

Using the card	POSSIBLE CAUSES	ACTION REQUIRED
The card does not lock or unlock the doors.	Card battery is flat.	Replace the battery. You will still be able to lock/unlock and start your ➔ 47 and ➔ 180 vehicle.
	Use of appliances operating on the same frequency as the card (mobile phone, etc.).	Stop using the devices or use the built-in key ➔ 47 .
	Vehicle located in a high electromagnetic radiation zone. Vehicle battery flat.	Use the key that is built into the card ➔ 47 .
	The "Place card on zone + START" message appears on the instrument panel.	Place your card on the placement area ➔ 180 then press the button START.
	The vehicle is started.	While the engine is on, it is not possible to lock/unlock using the card. Turn off the ignition.
	Desynchronisation of the card.	Unlock the driver's door by inserting the card's built-in key into the door lock ➔ 49 , then place the card on the placement area ➔ 180 and press the button START to synchronise the card.

6

OPERATING FAULTS

Using the remote control	POSSIBLE CAUSES	ACTION REQUIRED
The remote control does not lock or unlock the doors.	The remote control battery is flat.	Use the emergency key.
	Use of appliances operating on the same frequency as the remote control (mobile phone, etc.).	Stop using the devices or use the key.
	Vehicle located in a high electromagnetic radiation zone. Discharged battery.	Replace the battery. You will still be able to lock, unlock, and start your vehicle → 47 and → 180 .
	The vehicle is started.	While the engine is on, it is not possible to lock/unlock using the key. Turn off the ignition.
	Desynchronisation of the remote control.	Unlock the driver's door by inserting the key into the door lock, then start the engine → 180 to synchronise the remote control.

OPERATING FAULTS

The starter is activated	POSSIBLE CAUSES	ACTION REQUIRED
The instrument panel indicator lights are weak or fail to light up and the starter does not turn.	Battery terminals not tight, battery terminals disconnected or oxidised.	Retighten, reconnect or clean them if they are oxidised.
	Discharged battery or not operational.	Connect another battery to the faulty battery → 351 or replace the battery if necessary. Do not push the vehicle if the steering column is locked.
	Faulty circuit.	Consult an approved dealer.
The engine will not start.	Starting conditions are not fulfilled.	→ 180
	The "hands-free" card does not work.	→ 180 and → 31 .
The engine cannot be switched off.	Card not detected.	→ 180 and → 31 .
	Electronic fault.	Press the starter button quickly five times.
The steering column remains locked.	Steering wheel locked.	Move the steering wheel while pressing the engine start button → 180 .
	Faulty circuit.	Consult an approved dealer.

OPERATING FAULTS

On the road	POSSIBLE CAUSES	ACTION REQUIRED
White smoke from the exhaust.	In the diesel version, this is necessarily a fault. Smoke may be caused by particle filter regeneration.	➔ 192
Smoke under the vehicle when starting the heating.	This is not necessarily a fault. The smoke may come from the heater. If this happens, the smoke will gradually disappear once the passenger compartment temperature has reached the appropriate level.	
Smoke under the bonnet.	Short-circuit or cooling system leak.	Stop, switch off the ignition, stand away from the vehicle and contact an approved dealer.
The oil pressure warning light comes on:		
while cornering or braking	The level is too low.	Add engine oil ➔ 324 .
is slow to go out or remains lit up under acceleration	Loss of oil pressure.	Stop the vehicle and contact an approved dealer.

OPERATING FAULTS

On the road	POSSIBLE CAUSES	ACTION REQUIRED
Steering becomes heavy.	Assistance overheating. Fault with the electric assistance motor. Fault in the assistance system.	Drive carefully at reduced speed, be aware of the level of force in the steering wheel needed to turn the wheels. Consult an approved dealer.
Vibrations.	Tyres not inflated to the correct pressure, incorrectly balanced or damaged.	Check the tyre pressures: if this is not the cause, have their condition checked by an approved dealer.
The engine is overheating. The coolant temperature indicator is in the warning zone and warning light  comes on.	Engine cooling fan not working. <hr/> Coolant leaks.	Stop the vehicle, switch off the engine and contact an approved dealer. Check the coolant reservoir: it should contain fluid. If there is no coolant, consult an approved dealer as soon as possible.
Coolant boiling in the coolant reservoir.	Mechanical fault: damaged cylinder head gasket.	Stop the engine. Call an approved dealer.



Radiator: in the event of a significant lack of coolant, remember that you must never top up using cold coolant while the engine is very hot. After any procedure on the vehicle which has involved even partial draining of the cooling system, it must be refilled with a new mixture prepared in the correct proportions. Reminder: only products approved by our Technical Department may be used for this purpose.

OPERATING FAULTS

Stopped	POSSIBLE CAUSES	ACTION RE-REQUIRED
The engine cooling fan starts to run after the ignition is switched off.	This is not necessarily a fault. The engine cooling fan group may start to run in order to regulate the engine temperature. This operation may last several minutes after the engine is switched off.	
	The engine cooling fan runs for more than 10 minutes after the engine is switched off.	Consult an approved dealer.

OPERATING FAULTS

Electrical equipment	POSSIBLE CAUSES	ACTION REQUIRED
The wipers do not work.	Wiper blades stuck.	Free the blades before using the wipers.
	Faulty electrical circuit.	Consult an approved dealer.
	Fuse damaged.	Replace the fuse or have it replaced → 363.
The wiper does not stop.	Faulty electrical controls.	Consult an approved dealer.
Direction indicators flashing more quickly.	Faulty rear bulb.	→ 353 or → 353.
The indicators are not working.	Faulty electrical circuit or control.	Consult an approved dealer.
	Fuse damaged.	Replace the fuse or have it replaced → 363.
The headlights do not switch on or off.	Faulty electrical circuit or control.	Consult an approved dealer.
	Fuse damaged.	Replace the fuse or have it replaced → 363.

Electrical equipment	POSSIBLE CAUSES	ACTION REQUIRED
Traces of condensation in the headlights or rear lights.	Traces of condensation may be a natural phenomenon caused by variations in temperature and humidity.	In this case, the traces will disappear slowly once the lights are switched on.
The front seat belt reminder warning light comes on when the seat belts are fastened.	An object is stuck between the floor and the seat and is disrupting the operation of the sensor.	Remove all objects from underneath the front seats.

INFORMATION ABOUT THE VEHICLE

Vehicle identification plates

Vehicle identification plate

The information shown on the vehicle identification plate should be quoted on all correspondence or orders.

The presence and location of the information depends on the vehicle.

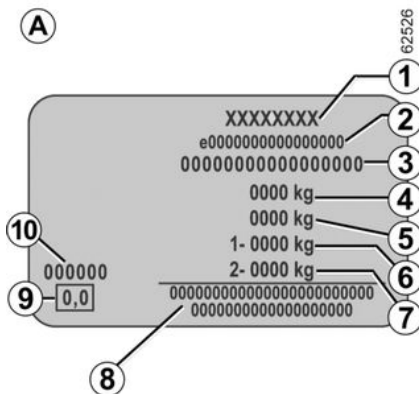

Manufacturer's plate: details

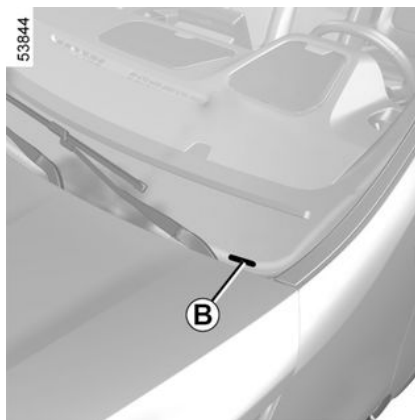
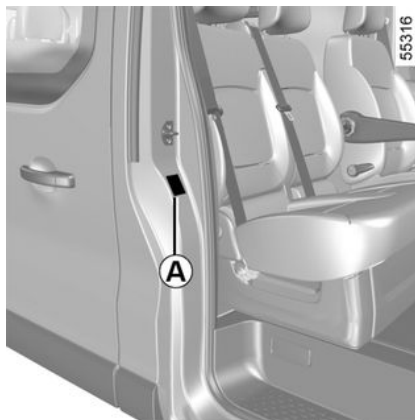

Manufacturer's plate A

1. Manufacturer name.
 2. EC design number or approval number.
 3. Identification number.
- B. Depending on the vehicle, this information is also provided on the marking.**
4. MMAC (Maximum permissible all-up weight).
 5. MTR (Gross Train Weight: vehicle fully loaded, with trailer).
 6. MMTA (Maximum Permissible Weight) front axle.
 7. MMTA rear axle.
 8. Reserved for related or additional entries.
 9. Diesel exhaust emissions.
- Depending on the vehicle, this information may not be indicated on the manufacturer's plate but on the engine smoke opacity label ➔ 192.
10. Paint reference (colour code).

INFORMATION ABOUT THE VEHICLE

Technical Information for the emergency services

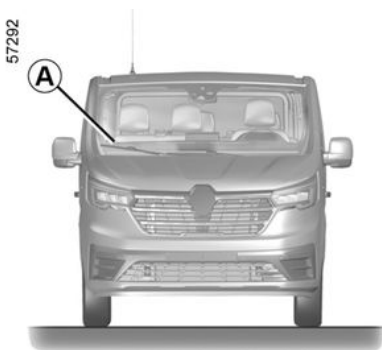

Engine identification, engine specifications

Engine identification

(Location varies depending on engine)

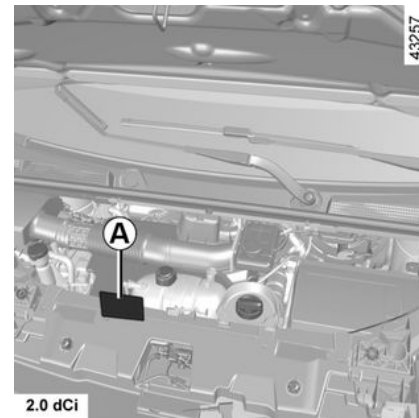
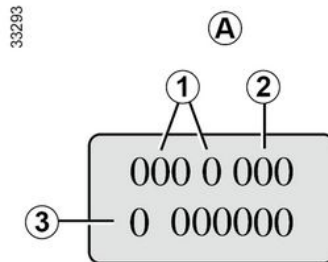

Please quote the engine identification information provided in zone A in all correspondence or orders.

1. Engine type.
2. Engine suffix.
3. Engine serial number.

7

The QR Code on label **A** allows emergency workers to use a tablet or smartphone to immediately access technical information that is useful for working on the vehicle in the event of an accident.

Make sure that the label **A** is always visible and present on the windscreen.

Any modification or damage would prevent access to the information.

INFORMATION ABOUT THE VEHICLE

Engine specifications

Versions	2.0 dCi	
Engine type (see engine plate)	M9R	
Cubic capacity (cc)	1997	
Type of fuel Octane rating	Diesel The label located in the fuel filler flap indicates the authorised fuels.	
Fuel types that meet European standards and are compatible with the engines of vehicles sold in Europe (in any other case, contact an Approved Dealer).	<div style="border: 1px solid black; border-radius: 5px; padding: 5px; display: inline-block; margin-bottom: 10px;">B7</div> Diesel fuel compliant with standard EN 590 containing up to 7% fatty acid methyl ester in volume.	
	<div style="border: 1px solid black; border-radius: 5px; padding: 5px; display: inline-block; margin-bottom: 10px;">B10</div> Diesel fuel compliant with standard EN 16734 containing up to 10% fatty acid methyl ester in volume.	
	<div style="border: 1px solid black; border-radius: 5px; padding: 5px; display: inline-block; margin-bottom: 10px;">XTL</div> Paraffinic Diesel fuel compliant with standard EN 15940 containing up to 7% fatty acid methyl ester in volume.	
Spark plugs	-	-

INFORMATION ABOUT THE VEHICLE

Dimensions (in metres)

Van version

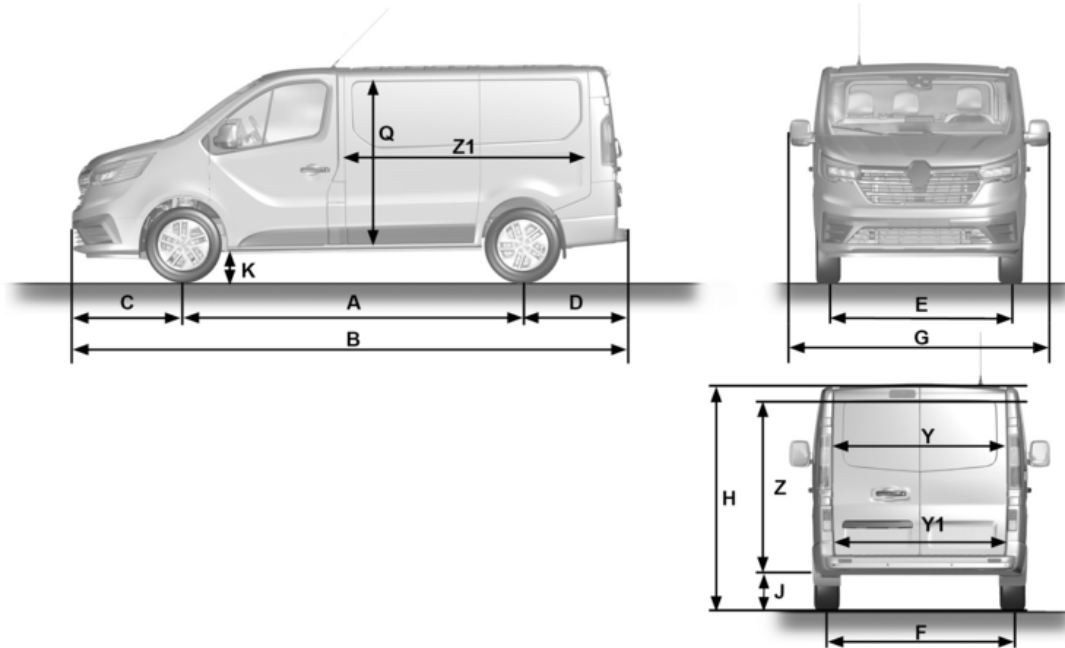

53856

7

INFORMATION ABOUT THE VEHICLE

Complete vehicles without recent alterations

VAN	Standard chassis		Long chassis	
	Standard van	Raised van	Standard van	Raised van
A	3,098		3,498	
B	5,080		5,480	
C	1,014			
D	0,968			
E	1,615			
F	1,628			
G	2,312 → 2,165 ⁽¹⁾			
H⁽²⁾	1,953 → 1,997	2,476 → 2,509	1,953 → 1,997	2,476 → 2,509
J⁽²⁾	0,552			
K⁽³⁾	0,160 → 0,166			
Q	1,387	1,913	1,387	1,913
Y	1,370	1,167	1,370	1,167
Y1	1,391			
Z	1,295	1,818	1,295	1,818
Z1	2,537		2,937	

(1) Door mirrors folded in

(2) Unloaded

(3) Loaded.

INFORMATION ABOUT THE VEHICLE

Combi version

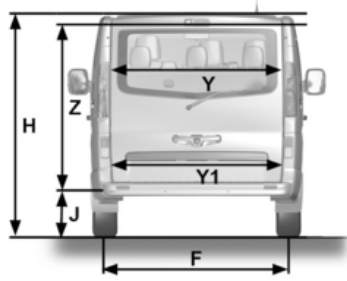
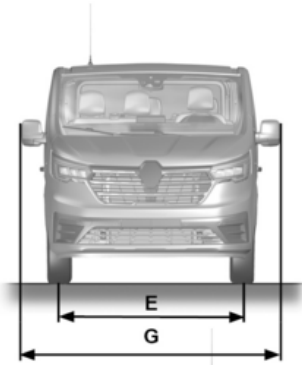
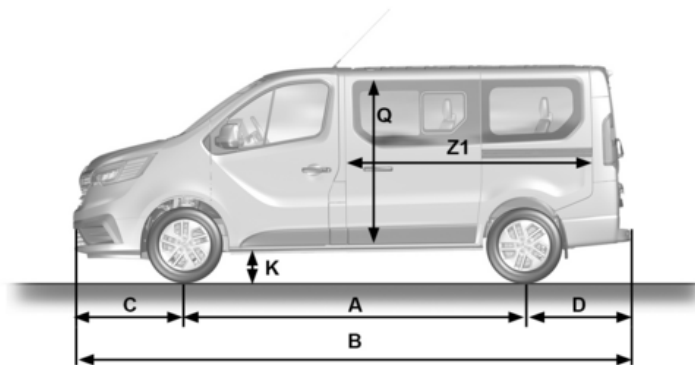

53646

7

INFORMATION ABOUT THE VEHICLE

Complete vehicles without recent alterations

COMBI	Standard chassis		Long chassis	
	With 3 rd row bench seat	Without 3 rd row bench seat	With 3 rd row bench seat	Without 3 rd row bench seat
A	3,098		3,498	
B	5,080		5,480	
C	1,014			
D	0,968			
E	1,615			
F	1,628			
G	2,312 → 2,165 ⁽¹⁾			
H ⁽²⁾	1,935 → 2,020		1,935 → 2,020	
J ⁽²⁾	0,552			
K ⁽³⁾	0,160 → 0,161			
Q	1,369			
Y	1,370			
Y1	1,391			
Z	1,306			
Z1	0,736	1,620	1,136	2,020

(1) Door mirrors folded in

(2) Unloaded

(3) Loaded.

INFORMATION ABOUT THE VEHICLE

Weights (in kg)

The weights indicated are for a basic vehicle without options: they vary depending on your vehicle's equipment. Consult your approved Dealer.

Versions (marketed depending on country)	Standard VAN	Raised VAN
Maximum Permissible All-up Weight (MMAC) Maximum Permissible Weight (MMTA) Gross Train Weight (MTR)	Weights indicated on the vehicle identification plate → 375	
Braked trailer weight *	found by calculating: MTR - MMAC	
Unbraked trailer weight *	750	
Permissible nose weight *	100	
Maximum permissible load on roof	200 (including carrying device)	150 (including carrying device)

* Towing weight (towing a caravan, boat etc.)

Towing is prohibited when the MTR - MMAC calculation is equal to zero, or when the MTR is equal to zero (or is not listed) on the identification plate.

- It is important to respect local towing regulations in force, specifically those set out in the Highway Code. Contact an approved Dealer for any modifications to towing equipment.
- For vehicles fitted with a trailer, **the total train weight (vehicle + trailer) must never be exceeded**. However the following is tolerated:
 - rear axle MMTA exceeded by no more than 15%;
 - the MMAC exceeded by no more than 10% or 100 kg (whichever limit is reached first).

In either case, the maximum speed of the vehicle and trailer must not exceed 50 mph (80 km/h), depending on local legislation, and the tyre pressure must be increased by 0.2 bar (3 PSI).

- The engine output and climbing capability are reduced with altitude. We recommend that the maximum load be reduced by 10% at an altitude of 1,000 metres and by an additional 10% for each 1,000 metres thereafter.

INFORMATION ABOUT THE VEHICLE

The weights indicated are for a basic vehicle without options: they vary depending on your vehicle's equipment. Consult your approved Dealer.

COMBI Versions (versions marketed depend on country)	
Maximum Permissible All-up Weight (MMAC) Maximum Permissible Weight (MMTA) Gross Train Weight (MTR)	Weights indicated on the vehicle identification plate → 375
Braked trailer weight *	found by calculating: MTR - MMAC
Unbraked trailer weight *	750
Permissible nose weight *	100
Maximum permissible load on roof	200 (including carrying device)

* Towing weight (towing a caravan, boat etc.)

Towing is prohibited when the MTR - MMAC calculation is equal to zero, or when the MTR is equal to zero (or is not listed) on the identification plate.

- It is important to respect local towing regulations in force, specifically those set out in the Highway Code. Contact an approved Dealer about adapting any towing equipment.
- For vehicles fitted with a trailer, **the total train weight (vehicle + trailer) must never be exceeded**. However the following is tolerated:
 - rear axle MMTA exceeded by no more than 15%;
 - the MMAC exceeded by no more than 10% or 100 kg (whichever limit is reached first).

In both cases, the maximum speed of the vehicle and trailer must not exceed 62 mph (100 km/h), depending on local legislation, and the tyre pressure must be increased by 0.2 bar (3 PSI).

- The engine output and climbing capability are reduced with altitude. We recommend that the maximum load be reduced by 10% at an altitude of 1,000 metres and by an additional 10% for each 1,000 metres thereafter.

REPLACEMENT PARTS AND REPAIRS

Original parts are based on very stringent specifications and are subjected to specific tests. Therefore, they are of at least the same level of quality as the parts fitted originally.

If you always fit genuine replacement parts to your vehicle, you will ensure that it performs well. Furthermore, repairs carried out in the approved dealer network with original parts are guaranteed according to the conditions stated on the back of the repair order.

SERVICE SHEETS

VIN:

Date:	Miles (km):	Invoice number:	Comments/miscellaneous
Type of operation: Service <input type="checkbox"/> <input type="checkbox"/>		Stamp	
Anticorrosion check: OK <input type="checkbox"/> Not OK* <input type="checkbox"/>			
Date:	Miles (km):	Invoice number:	Comments/miscellaneous
Type of operation: Service <input type="checkbox"/> <input type="checkbox"/>		Stamp	
Anticorrosion check: OK <input type="checkbox"/> Not OK* <input type="checkbox"/>			
Date:	Miles (km):	Invoice number:	Comments/miscellaneous
Type of operation: Service <input type="checkbox"/> <input type="checkbox"/>		Stamp	
Anticorrosion check: OK <input type="checkbox"/> Not OK* <input type="checkbox"/>			

* See specific page

SERVICE SHEETS

VIN:

Date:	Miles (km):	Invoice number:	Comments/miscellaneous
Type of operation: Service <input type="checkbox"/> <input type="checkbox"/>		Stamp	
Anticorrosion check: OK <input type="checkbox"/> Not OK* <input type="checkbox"/>			

Date:	Miles (km):	Invoice number:	Comments/miscellaneous
Type of operation: Service <input type="checkbox"/> <input type="checkbox"/>		Stamp	
Anticorrosion check: OK <input type="checkbox"/> Not OK* <input type="checkbox"/>			

Date:	Miles (km):	Invoice number:	Comments/miscellaneous
Type of operation: Service <input type="checkbox"/> <input type="checkbox"/>		Stamp	
Anticorrosion check: OK <input type="checkbox"/> Not OK* <input type="checkbox"/>			

* See specific page

7

SERVICE SHEETS

VIN:

Date:	Miles (km):	Invoice number:	Comments/miscellaneous
Type of operation:		Stamp	
Service <input type="checkbox"/>			
..... <input type="checkbox"/>			
Anticorrosion check:			
OK <input type="checkbox"/> Not OK* <input type="checkbox"/>			
Date:	Miles (km):	Invoice number:	Comments/miscellaneous
Type of operation:		Stamp	
Service <input type="checkbox"/>			
..... <input type="checkbox"/>			
Anticorrosion check:			
OK <input type="checkbox"/> Not OK* <input type="checkbox"/>			
Date:	Miles (km):	Invoice number:	Comments/miscellaneous
Type of operation:		Stamp	
Service <input type="checkbox"/>			
..... <input type="checkbox"/>			
Anticorrosion check:			
OK <input type="checkbox"/> Not OK* <input type="checkbox"/>			

* See specific page

SERVICE SHEETS

VIN:

Date:	Miles (km):	Invoice number:	Comments/miscellaneous
Type of operation:		Stamp	
Service <input type="checkbox"/>			
..... <input type="checkbox"/>			
Anticorrosion check:			
OK <input type="checkbox"/> Not OK* <input type="checkbox"/>			
Date:	Miles (km):	Invoice number:	Comments/miscellaneous
Type of operation:		Stamp	
Service <input type="checkbox"/>			
..... <input type="checkbox"/>			
Anticorrosion check:			
OK <input type="checkbox"/> Not OK* <input type="checkbox"/>			
Date:	Miles (km):	Invoice number:	Comments/miscellaneous
Type of operation:		Stamp	
Service <input type="checkbox"/>			
..... <input type="checkbox"/>			
Anticorrosion check:			
OK <input type="checkbox"/> Not OK* <input type="checkbox"/>			

* See specific page

7

SERVICE SHEETS

VIN:

Date:	Miles (km):	Invoice number:	Comments/miscellaneous
Type of operation:		Stamp	
Service <input type="checkbox"/>			
..... <input type="checkbox"/>			
Anticorrosion check:			
OK <input type="checkbox"/> Not OK* <input type="checkbox"/>			
Date:	Miles (km):	Invoice number:	Comments/miscellaneous
Type of operation:		Stamp	
Service <input type="checkbox"/>			
..... <input type="checkbox"/>			
Anticorrosion check:			
OK <input type="checkbox"/> Not OK* <input type="checkbox"/>			
Date:	Miles (km):	Invoice number:	Comments/miscellaneous
Type of operation:		Stamp	
Service <input type="checkbox"/>			
..... <input type="checkbox"/>			
Anticorrosion check:			
OK <input type="checkbox"/> Not OK* <input type="checkbox"/>			

* See specific page

SERVICE SHEETS

VIN:

Date:	Miles (km):	Invoice number:	Comments/miscellaneous
Type of operation:		Stamp	
Service <input type="checkbox"/>			
..... <input type="checkbox"/>			
Anticorrosion check:			
OK <input type="checkbox"/> Not OK* <input type="checkbox"/>			
Date:	Miles (km):	Invoice number:	Comments/miscellaneous
Type of operation:		Stamp	
Service <input type="checkbox"/>			
..... <input type="checkbox"/>			
Anticorrosion check:			
OK <input type="checkbox"/> Not OK* <input type="checkbox"/>			
Date:	Miles (km):	Invoice number:	Comments/miscellaneous
Type of operation:		Stamp	
Service <input type="checkbox"/>			
..... <input type="checkbox"/>			
Anticorrosion check:			
OK <input type="checkbox"/> Not OK* <input type="checkbox"/>			

* See specific page

7

ANTICORROSION CHECK

If the continuation of the warranty is subject to repair, it is indicated below.

VIN:

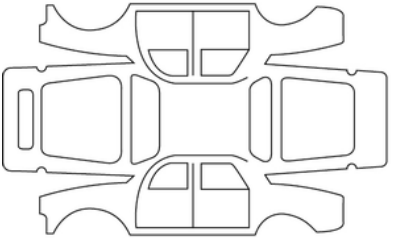
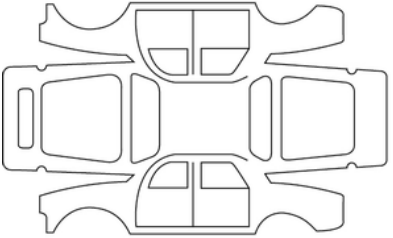
Date of repair:		Stamp
Corrosion repair operation to be carried out:		
Date of repair:		Stamp
Repair to be carried out:		

ANTICORROSION CHECK

If the continuation of the warranty is subject to repair, it is indicated below.

VIN:

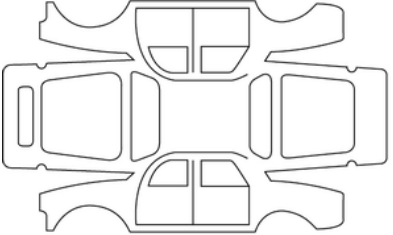
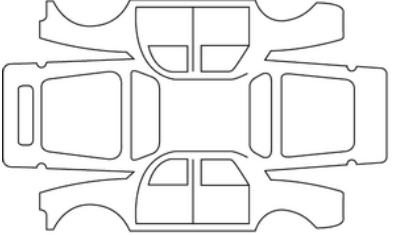
Date of repair:		Stamp
Corrosion repair operation to be carried out:		
Date of repair:		Stamp
Repair to be carried out:		

7

ANTICORROSION CHECK

If the continuation of the warranty is subject to repair, it is indicated below.

VIN:

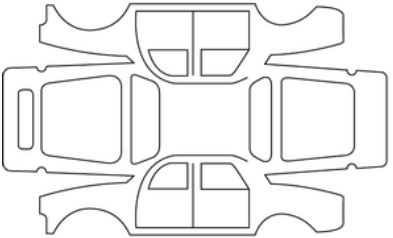
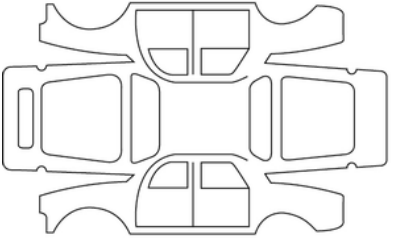
Date of repair:		Stamp
Corrosion repair operation to be carried out:		
Date of repair:		Stamp
Repair to be carried out:		

ANTICORROSION CHECK

If the continuation of the warranty is subject to repair, it is indicated below.

VIN:

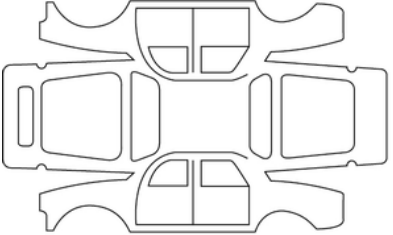
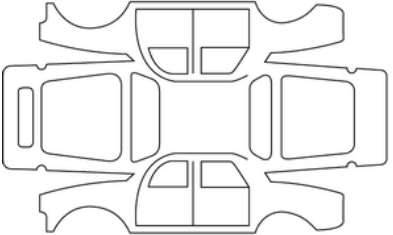
Date of repair:		Stamp
Corrosion repair operation to be carried out:		
Date of repair:		Stamp
Repair to be carried out:		

7

ANTICORROSION CHECK

If the continuation of the warranty is subject to repair, it is indicated below.

VIN:

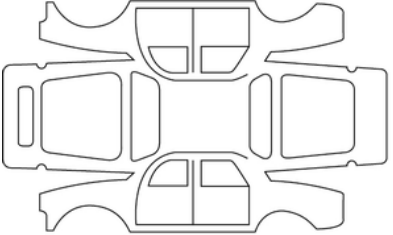
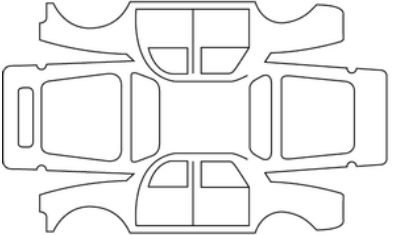
Date of repair:		Stamp
Corrosion repair operation to be carried out:		
Date of repair:		Stamp
Repair to be carried out:		

ANTICORROSION CHECK

If the continuation of the warranty is subject to repair, it is indicated below.

VIN:

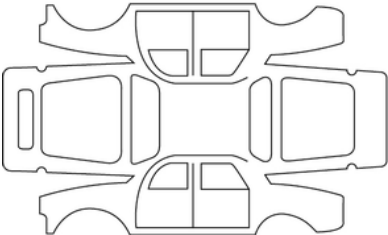
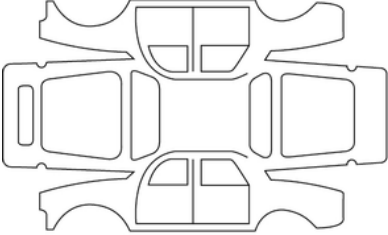
Date of repair:		Stamp
Corrosion repair operation to be carried out:		
Date of repair:		Stamp
Repair to be carried out:		

7

ANTICORROSION CHECK

If the continuation of the warranty is subject to repair, it is indicated below.

VIN:

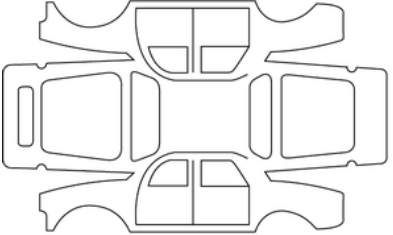
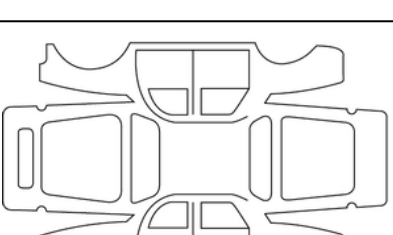
Date of repair:		Stamp
Corrosion repair operation to be carried out:		
Date of repair:		Stamp
Repair to be carried out:		

ALPHABETICAL INDEX

A

ABS, [210](#)
Accessories: accessory sockets, [303](#)
Access to the engine compartment, [323](#)
Active emergency braking, [233](#), [233](#)
Adaptive cruise control, [258](#), [258](#)
AdBlue, [175](#)
Additional heating and air conditioning, [293](#)
Additional methods of restraint, [79](#)
Additive (reagent), [175](#)
Adjusting the front seats, [54](#), [54](#)
Adjusting your driving position, [54](#), [54](#), [58](#), [63](#), [63](#)
Airbag, [71](#), [77](#)
Airbag : activating the front passenger airbag, [128](#)
Airbag : deactivating the front passenger airbag, [128](#)
Airbag activating the front passenger airbags, [128](#)
Airbag inflatable cushion, [71](#), [77](#)
Airbags : child safety, [128](#)
Air conditioning, [287](#), [287](#), [291](#), [291](#), [293](#)
Air conditioning: information and advice for use, [295](#)
Air Vents, [282](#), [282](#), [284](#)
Anti-corrosion protection, [332](#)
Anti-lock braking system : ABS, [210](#)
Armrest, [54](#)
Assistance: assistance for driving with a trailer, [211](#)
Audible alarm: lights-on reminder, [163](#)
Audible and visual signals, [166](#), [166](#)
Automatic gearbox: use, [188](#)

Automatic gearbox (use), [189](#)
Automatic gearbox selector lever, [189](#)
Automatic locking when driving, [52](#)

B

Battery, [330](#)
Battery: troubleshooting, [349](#)
Blind spot: warning, [223](#)
Blind spot warning, [223](#), [223](#)
Bonnet, [323](#), [323](#)
Breakdown recovery towing, [349](#)

C

Caravan towing, [320](#)
Card, [20](#), [22](#), [31](#)
Card: battery, [20](#), [22](#), [31](#)
Card: emergency key, [20](#)
Card: engine not starting in hands-free mode, [20](#)
Card: hands-free, [20](#)
Card: locking/unlocking the opening elements, [20](#)
Card: use, [20](#), [22](#), [31](#), [181](#)
Card engine not starting in hands-free mode, [20](#), [22](#), [31](#)
Catalytic converter, [192](#)
Central door locking, [31](#), [36](#), [36](#), [39](#), [42](#), [44](#), [48](#), [49](#), [53](#)
Changing a wheel, [346](#)
Changing gears, [189](#), [199](#)
Children, [80](#), [299](#)
Child restraint, [80](#), [88](#)

ALPHABETICAL INDEX

Child restraint devices, [80](#), [88](#)
Child restraint system, [80](#), [88](#)
Child safety, [80](#), [80](#), [88](#), [299](#)
Child seats, [80](#), [81](#), [85](#), [88](#)
Cleaning: vehicle interior, [334](#)
Clock, [150](#), [151](#), [151](#)
Closing the doors, [41](#)
Control instruments, [145](#), [151](#)
Controls, [258](#)
Control warning lights, [145](#)
Cornering lights, [164](#)
Cornering lights: operation, [164](#)
Courtesy light, [301](#)
Cruise control, [254](#), [254](#)
Cruise control - speed limiter, [250](#), [254](#)
Cup holders, [306](#)
Customising the vehicle settings, [169](#)

D

Dashboard, [306](#)
Daytime running lights, [36](#), [160](#)
Daytime running lights: operation, [160](#)
Deadlocking the doors, [31](#), [39](#)
De-icing/demisting the windscreen, [291](#)
De-misting/De-icing: rear view mirrors, [158](#)
Demisting the rear window, [291](#)
Detection of pedestrians, [233](#)
Detection of road signs, [242](#)

Detection of road signs: overspeed warning, [245](#)
Detection of vehicles, [233](#)
Diesel: ignition switch, [179](#), [180](#)
Diesel: running in, [179](#)
Diesel: running out of fuel, [192](#)
Dimensions, [378](#)
Dipped beam headlights, [160](#)
Dipped beam headlights: operation, [160](#)
Direction indicators, [166](#)
Display, [145](#), [145](#)
Door or luggage compartment door open buzzer, [41](#), [42](#), [44](#), [46](#)
Doors, [41](#), [44](#)
Doors/luggage compartment door, [20](#), [31](#), [36](#), [36](#), [39](#), [48](#), [53](#)
Driver assistance, [216](#), [223](#), [229](#), [233](#), [245](#), [258](#)
Driver vigilance warning, [240](#)
Driving, [180](#), [189](#), [199](#), [204](#), [216](#), [223](#), [229](#), [233](#), [250](#), [254](#), [258](#), [269](#)
Driving advice, [199](#), [199](#)
Driving aids, [216](#), [223](#), [229](#), [233](#), [245](#), [258](#)
Driving aids: active emergency braking, [233](#)
Driving aids: safety distance warning, [229](#)
Driving aids adaptive cruise control, [258](#)
Driving position, [130](#)
Driving position settings, [63](#)
Driving style warning lights, [199](#)

E

ECO driving, [199](#), [199](#)

ALPHABETICAL INDEX

Electric windows, [299](#), [299](#)
Electronic stability control: ESC, [211](#)
Emergency brake assist, [211](#)
Emergency braking, [233](#)
Emergency key, [20](#)
Emergency spare wheel, [336](#), [345](#)
Emission control advice, [198](#), [198](#)
Engine: ignition switch, [180](#)
Engine identification, [376](#), [376](#)
Engine oil, [324](#), [326](#)
Engine oil capacities, [326](#)
Engine oil level, [324](#), [326](#)
Engine specifications, [376](#), [377](#)
Engine start/stop button, [180](#)
Environment, [197](#), [197](#)
ESC : electronic stability control, [211](#)
Excessive speed audible alarm, [145](#)
Excessive speed warning, [245](#)
Exterior: bodywork maintenance, [332](#)
Exterior lighting and signals, [160](#)
Exterior lights, [166](#), [353](#)

F

Fast idle speed, [249](#)
Filling with fuel, [173](#)
Filter: oil, [326](#)
Fitting accessories, [322](#), [366](#)
Fitting a child seat, [82](#), [85](#)

Fitting a radio, [365](#), [365](#), [365](#)
Fog lights, [164](#), [164](#)
Fog lights: operation, [164](#), [164](#)
Folding in the door mirrors, [158](#)
Folding the rear bench seat, [58](#)
For child safety, [41](#), [42](#), [44](#), [46](#)
Free-wheel, [199](#)
Front armrest, [54](#)
Front headlights, [353](#)
Front headrests, [54](#)
Front seat adjustment, [54](#)
Front seatbacks, [54](#), [63](#)
Front seat belt pretensioners, [71](#)
Front seats, [54](#)
Fuel consumption, [199](#), [199](#)
Fuel economy, [199](#)
Fuel grade, [173](#)
Fuel range, [145](#)
Fuel tank, [172](#)
Fuel tank cap, [173](#)
Fuel tank capacity, [173](#)
Fuel tips for reducing consumption, [199](#)
Function performance mode, [199](#)
Fuses, [363](#), [364](#)

G

Gear change indicators, [199](#)
Gear change paddles, [189](#)

ALPHABETICAL INDEX

Gear control, [188](#)
Gearstick, [188](#), [189](#)
Glovebox, [310](#)
Grab handle, [313](#)

H

Handbrake, [196](#)
Headlight beam adjustment, [165](#)
Headlight beam adjustments, [165](#)
Headrests, [54](#), [58](#)
Heated seats, [55](#)
Heated windscreen, [291](#)
Heating and air conditioning system, [282](#), [287](#), [291](#), [293](#)
Heating system, [282](#), [287](#), [291](#)
Hill start assistance, [213](#)
Horn, [166](#)

I

Idle speed, [249](#)
Ignition switch, [180](#), [181](#)
Indicators, [166](#)
Instrument panel, [145](#), [184](#), [199](#)
Instrument panel warning lights, [145](#), [175](#), [184](#), [199](#)
Interior: storage, [306](#), [310](#), [313](#)
Interior lighting, [301](#)
Interior lighting: changing bulbs, [357](#)
Interior trim maintenance, [334](#)

K

Key/radio frequency remote control: use, [36](#), [36](#)
Key/Remote control, [34](#)
Keys, [36](#), [36](#)

L

Lane departure warning, [216](#), [216](#)
Levels, [323](#), [326](#)
Lighting: interior, [301](#)
Lighting signals, [160](#)
Lights: replacing bulbs, [353](#)
Lights-on reminder audible alarm, [41](#), [42](#), [163](#)
Location of fuses, [363](#)
Locking/unlocking the opening elements deadlocking the opening elements, [31](#), [39](#)
Locking/unlocking the opening elements hands-free mode, [31](#)
Locking remote control, [36](#)
Locking the doors, [20](#), [31](#), [36](#), [36](#), [39](#), [41](#), [42](#), [48](#), [49](#), [53](#)
Luggage compartment, [316](#), [318](#)
Luggage cover, [317](#)
Luggage net, [318](#), [318](#)

M

Main beam headlights, [161](#)
Main beam headlights: operation, [161](#)
Maintenance, [198](#)
Maintenance: advice for maintenance and emission control, [198](#)
Maintenance: bodywork, [332](#)

ALPHABETICAL INDEX

Maintenance: interior trim, [334](#)
Maintenance: interior trims, [334](#)
Maintenance: mechanical, [330](#)
Maintenance: tyres, [336](#)
Manual air conditioning, [286](#)

Messages on the instrument panel, [142](#), [175](#), [184](#)

METHODS OF RESTRAINT IN ADDITION TO REAR SEAT BELTS,
[77](#)

Methods of restraint in addition to the front seat belts, [71](#), [71](#)

Multimedia equipment, [297](#), [365](#)

Multimedia screen screens, [216](#)

O

Oil change, [326](#)

Opening elements, [41](#), [41](#), [42](#), [44](#), [46](#)

Opening elements - locking / unlocking, [22](#), [31](#), [36](#), [39](#)

Opening the doors, [41](#)

Operating faults, [184](#), [189](#), [189](#), [216](#)

Operating faults: automatic gearbox, [188](#)

Operating faults: card batteries, [20](#)

Operating faults: warning messages on the trip computer, [143](#)

Operation, [189](#)

Overspeed function, [215](#)

P

Paintwork maintenance, [332](#)

Parking brake, [196](#)

Parking distance control, [269](#), [269](#)

Particle filter, [192](#), [192](#)

Passenger safety: front passenger airbag, [128](#)

Performance mode, [199](#)

Petrol: ignition switch, [180](#)

Power-assisted steering, [157](#), [157](#)

Power consumption, [145](#)

Power performance mode, [199](#)

Precautions for use recommendations, [168](#)

Pretensioners, [71](#)

Puncture, [342](#), [345](#)

Puncture: emergency spare wheel, [344](#)

Puncture: tool, [342](#)

Put the engine on standby, [184](#)

R

Reagent (tank), [175](#)

Reagent filling, [175](#)

Reagent grade, [175](#)

Reagent tank, [175](#), [175](#)

Reagent tank capacity, [175](#)

Rear bench seat, [58](#), [58](#)

Rear headrests, [58](#)

Rear seatbacks, [58](#), [63](#)

Rear seats, [58](#), [63](#)

Rear seats Functions, [58](#)

Rear view mirrors, [158](#)

Replacement and repair parts, [384](#)

Replacement of front light bulbs, [353](#)

ALPHABETICAL INDEX

Replacement of rear light bulbs, [354](#)
Restraint devices in addition to the rear seat belts, [77](#)
Restraint in addition to the seatbelts, [71](#), [77](#), [77](#)
Reverse gear: shift, [188](#)
Reversing camera, [274](#), [274](#)
Reversing radar, [269](#)
Roof bars, [322](#), [322](#)
Roof bars rack, [322](#)
Running in, [179](#)

S

Safe distance alert, [229](#), [229](#)
Safe distances, [229](#)
SCR: selective catalytic reduction, [175](#)
Seat base: driving position, [63](#)
Seat belts, [63](#), [63](#), [71](#)
Seat belts: adjustment of driving position, [63](#)
Seat belts: seat belt reminder warning light, [64](#)
Seats: front seat table position, [310](#)
Seats: heated, [55](#)
Securing rings, [316](#), [318](#)
Selecting reverse gear, [189](#)
Side lights, [160](#)
Side protection devices, [77](#), [77](#)
Speakers location, [365](#)
Special features of Diesel vehicles, [192](#)
Speed limiter, [250](#), [250](#)
Spoiler, [322](#)

Spotlights, [301](#)
Starting the engine, [180](#), [180](#), [180](#), [184](#)
Steering wheel: adjustment, [157](#)
Steering wheel: driving position adjustment, [157](#)
Steering wheel: variable power assisted steering, [157](#)
Stop and Start, [184](#), [199](#)
Stop and Start function, [184](#)
Stopping the engine, [180](#), [180](#)
Storage compartment, [306](#)
Storage compartment/fitings: passenger compartment, [306](#)
Storage compartments/fitings: luggage compartment, [313](#)
Sun visor, [301](#), [301](#), [306](#)
Switching on the vehicle ignition, [180](#)

T

Tailgate, [46](#)
Temperature, [150](#)
Temperature: temperature/time screen, [150](#)
Temperature regulation, [291](#)
Tools, [342](#)
Towbar, [320](#)
Towbar mounting, [320](#)
Towbar towing, [320](#)
Towing: breakdown, [349](#)
Towing: towing: driving assistance function, [211](#)
Towing rings, [349](#)
Traction control, [212](#)
Transporting children, [80](#), [88](#)

ALPHABETICAL INDEX

Transporting objects: luggage net, [318](#)
Transporting objects in the luggage compartment, [316](#), [318](#)
Trip computer, [136](#)
Trip parameters (trip computer), [139](#)
Troubleshooting: tools, [342](#)
Tyre inflation, [338](#), [342](#)
Tyre inflation kit, [339](#), [342](#)
Tyre pressure, [199](#), [204](#), [338](#), [342](#)
Tyre pressure loss warning, [204](#), [342](#)
Tyre pressure monitoring system, [204](#)
Tyres, [199](#), [204](#), [336](#), [336](#), [338](#)
Tyres: inflation pressure, [338](#)
Tyres: puncture emergency spare wheel, [336](#)
Tyres: swapping wheels, [336](#)

U

Unlocking/Locking the opening elements, [47](#)
Unlocking the doors, [48](#), [49](#)
Use in winter, [192](#), [336](#), [336](#)
User precautions, [168](#)

V

Variable power assisted steering, [157](#)
Vehicle dimensions, [378](#)
Vehicle identification plates, [375](#)
Vehicle recycling, [197](#)
Ventilation, [284](#), [287](#), [291](#), [293](#)

W

Warning: warning messages on the trip computer, [144](#)
Washing, [332](#)
Weights, [382](#)
Wheels (safety), [336](#)
Wheel trims, [348](#)
Wide angle rear view mirror, [159](#), [301](#)
Windows, [299](#)
Windscreen demisting, [291](#)
Windscreen washer, [168](#), [169](#)
Wiper, [167](#), [168](#), [169](#)



RENAULT S.A.S. SOCIÉTÉ PAR ACTIONS SIMPLIFIÉE AU CAPITAL DE 533 941 113 € / 122-122 BIS, AVENUE DU GENERAL LECLERC
92100 BOULOGNE-BILLANCOURT R.C.S. NANTERRE 780 129 987 — SIRET 780 129 987 03591 / renaultgroup.com

NU 1374-8 - 77 11 416 327 - 06/2024 - Edition anglaise



7711416327

